

GP1S53 Compact Potointerrupter

■ Features

1. Compact type
2. High sensing accuracy (Slit width: 0.5mm)
3. PWB mounting type

■ Applications

1. OA equipment, such as FDDs, printers, facsimiles
2. VCRs
3. Optoelectronic switches

■ Outline Dimensions

(Unit : mm)

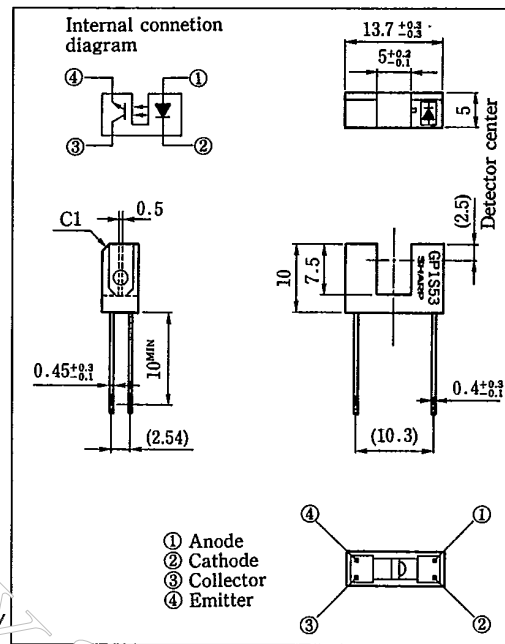

■ Absolute Maximum Rating

(Ta=25°C)

	Parameter	Symbol	Rating	Unit
Input	Forward current	I_F	50	mA
	*1 Peak forward current	I_{FM}	1	A
	Reverse voltage	V_R	6	V
	Power dissipation	P	75	mW
Output	Collector-emitter voltage	V_{CEO}	35	V
	Emitter-collector voltage	V_{ECO}	6	V
	Collector current	I_C	20	mA
	Collector power dissipation	P_C	75	mW
	Operating temperature	T_{opr}	-25 ~ +85	°C
	Storage temperature	T_{stg}	-40 ~ +100	°C
	**Soldering temperature	T_{sol}	260	°C

*1 Pulse width $\leq 100 \mu s$, Duty ratio = 0.01

*2 For 5 seconds

■ Electro-optical Characteristics

(Ta=25°C)

Parameter		Symbol	Conditions	MIN.	TYP.	MAX.	Unit
Input	Forward voltage	V_F	$I_F=20\text{mA}$	—	1.25	1.4	V
	Peak forward voltage	V_{FM}	$I_{FM}=0.5\text{A}$	—	3	4	V
	Reverse current	I_R	$V_R=3\text{V}$	—	—	10	μA
Output	Collector dark current	I_{CEO}	$V_{CE}=20\text{V}$	—	10^{-9}	10^{-7}	A
	Current transfer ratio	CTR	$I_F=20\text{mA}, V_{CE}=5\text{V}$	2.5	—	75	%
Transfer characteristics	Collector-emitter saturation voltage	$V_{CE(sat)}$	$I_F=40\text{mA}, I_C=0.2\text{mA}$	—	—	0.4	V
	Response time (Rise)	t_r	$V_{CE}=2\text{V}, I_C=2\text{mA}$	—	3	15	μs
	Response time (Fall)	t_f		—	4	20	μs
			$R_L=100\Omega$				

Fig. 1 Forward Current vs Ambient Temperature

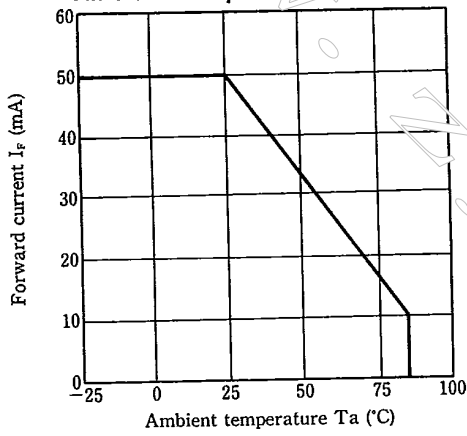

Fig. 2 Collector Power Dissipation vs. Ambient Temperature

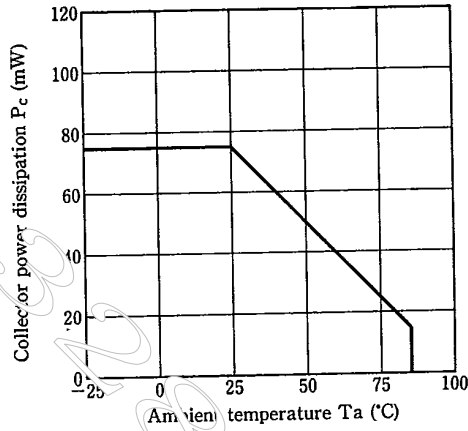

Fig. 3 Peak Forward Current vs. Duty Ratio

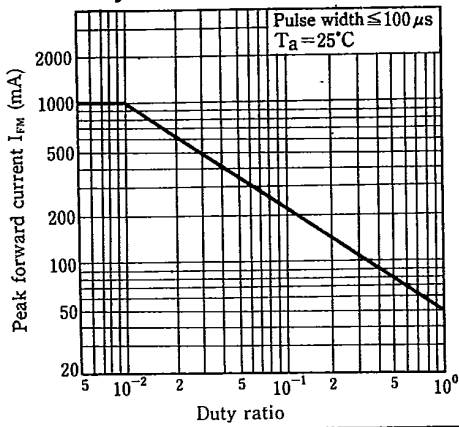

Fig. 4 Forward current vs. Forward Voltage

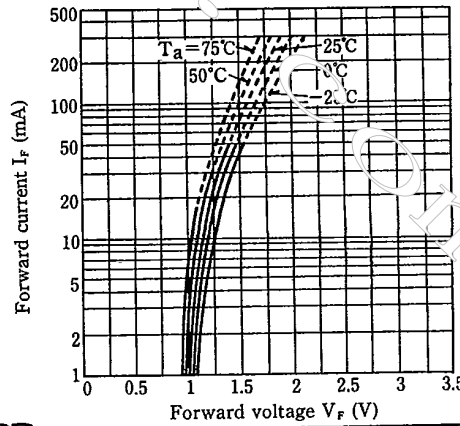

Fig. 5 Collector Current vs. Forward Current

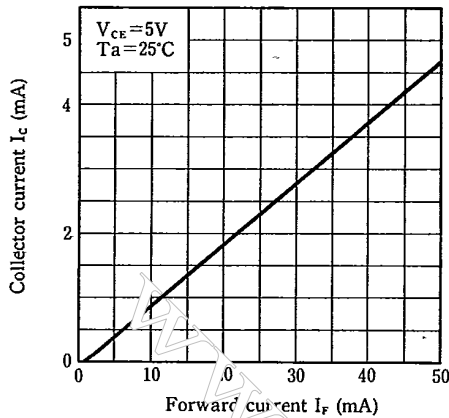

Fig. 6 Collector Current vs. Collector-emitter Voltage

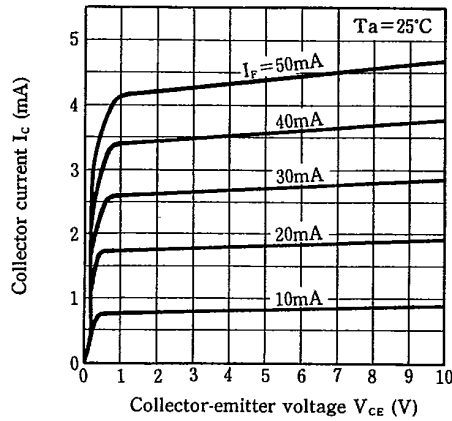

Fig. 7 Collector Current vs. Ambient Temperature

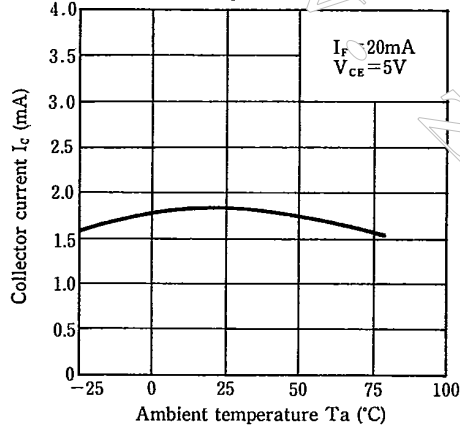

Fig. 8 Collector-emitter Saturation Voltage vs. Ambient Temperature

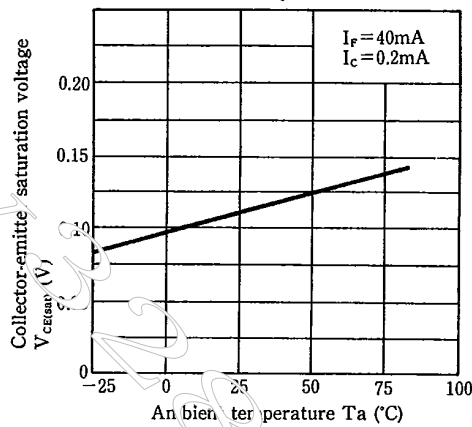
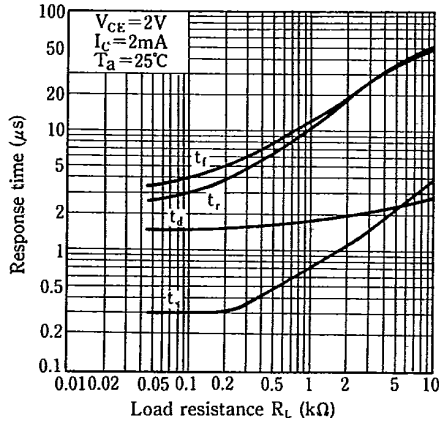

Fig. 9 Response Time vs. Load Resistance



Test Circuit for Response Time

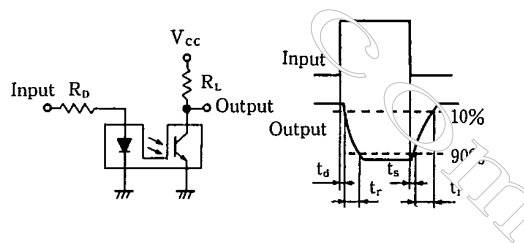

Fig. 10 Frequency Response

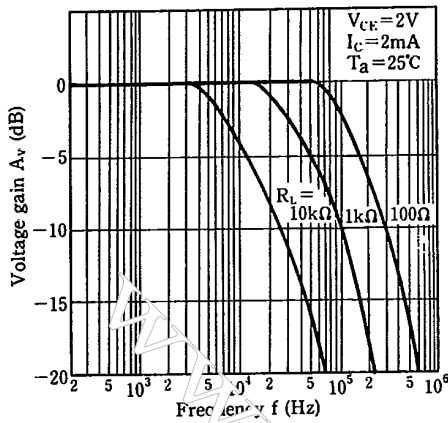

Fig. 11 Collector Dark Current vs. Ambient Temperature

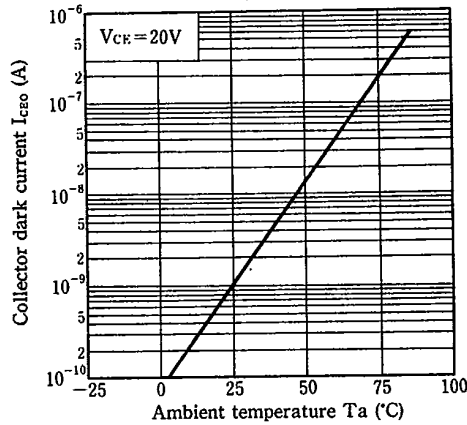

Fig. 12 Relative Collector Current vs. Shield Distance (1)

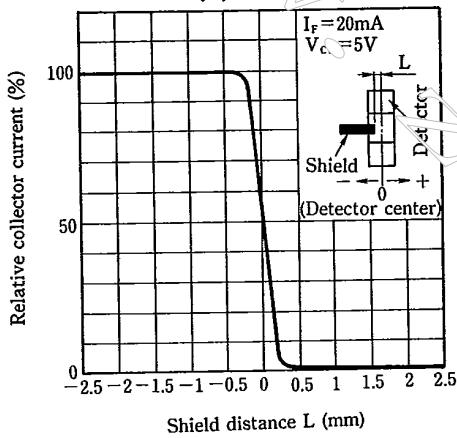

Fig. 13 Relative collector Current vs. Shield Distance (2)

