



SUPER-SEMI



SUPER-MOSFET

Super Junction Metal Oxide Semiconductor Field Effect Transistor

600V Super Junction Power Transistor
SS*20N60S

Rev. 1.2
May. 2018

www.supersemi.com.cn

SJ-FET

SSW20N60S/SSA20N60S 600V N-Channel MOSFET

Description

SJ-FET is new generation of high voltage MOSFET family that is utilizing an advanced charge balance mechanism for outstanding low on-resistance and lower gate charge performance. This advanced technology has been tailored to minimize conduction loss, provide superior switching performance, and withstand extreme dv/dt rate and higher avalanche energy. SJ-FET is suitable for various AC/DC power conversion in switching mode operation for higher efficiency.

Features

- Multi-Epi process SJ-FET
- 650V @T_J = 150 °C
- Typ. R_{DS(on)} = 0.16Ω
- Ultra Low Gate Charge (typ. Q_g = 30nC)
- 100% avalanche tested

SSW20N60S



SSA20N60S

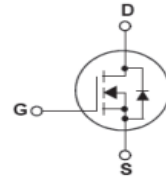
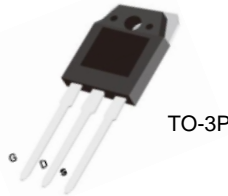

Absolute Maximum Ratings

Symbol	Parameter	SSW_A20N60S	Unit
V _{DSS}	Drain-Source Voltage	600	V
I _D	Drain Current -Continuous (TC = 25°C) -Continuous (TC = 100°C)	20* 12.6*	A
I _{DM}	Drain Current – Pulsed (Note 1)	62	A
V _{GSS}	Gate-Source voltage	±30	V
E _{AS}	Single Pulsed Avalanche Energy (Note 2)	485	mJ
I _{AR}	Avalanche Current (Note 1)	3.5	A
E _{AR}	Repetitive Avalanche Energy (Note 1)	1	mJ
dv/dt	Peak Diode Recovery dv/dt (Note 3)	15	V/ns
dVds/dt	Drain Source voltage slope (Vds=480V)	50	V/ns
P _D	Power Dissipation (TC = 25°C) -Derate above 25°C	151 1.67	W W/°C
T _J , T _{STG}	Operating and Storage Temperature Range	-55 to +150	°C
T _L	Maximum Lead Temperature for Soldering Purpose, 1/8" from Case for 5 Seconds	300	°C

* Drain current limited by maximum junction temperature. Maximum duty cycle D=0.75.

Thermal Characteristics

Symbol	Parameter	SSW_A 20N60S	Unit
R _{θJC}	Thermal Resistance, Junction-to-Case	0.83	°C/W
R _{θCS}	Thermal Resistance, Case-to-Sink Typ.	0.5	°C/W
R _{θJA}	Thermal Resistance, Junction-to-Ambient	62	°C/W



Electrical Characteristics TC = 25°C unless otherwise noted

SSW20N60S/SSA20N60S 600V N-Channel MOSFET

Symbol	Parameter	Conditions	Min	Typ	Max	Unit
Off Characteristics						
BVDSS	Drain-Source Breakdown Voltage	VGS = 0V, ID = 250μA, TJ = 25°C	600	-	-	V
		VGS = 0V, ID = 250μA, TJ = 150°C	-	650	-	V
ΔBVDSS / ΔTJ	Breakdown Voltage Temperature Coefficient	ID = 250μA, Referenced to 25°C	-	0.6	-	V/°C
IDSS	Zero Gate Voltage Drain Current	VDS = 600V, VGS = 0V -TJ = 150°C	-	-	1	μA
IGSSF	Gate-Body Leakage Current, Forward	VGS = 30V, VDS = 0V	-	-	100	nA
IGSSR	Gate-Body Leakage Current, Reverse	VGS = -30V, VDS = 0V	-	-	-100	nA
On Characteristics						
VGS(th)	Gate Threshold Voltage	VDS = VGS, ID = 250μA	2.5	-	4.5	V
RDS(on)	Static Drain-Source On-Resistance	VGS = 10V, ID = 10A	-	0.16	0.19	Ω
gFS	Forward Trans conductance	VDS = 40V, ID = 20A	-	19	-	S
Dynamic Characteristics						
Ciss	Input Capacitance	VDS = 25V, VGS = 0V, f = 1.0MHz	-	1440	-	pF
Coss	Output Capacitance		-	370	-	pF
Crss	Reverse Transfer Capacitance		-	11	-	pF
Switching Characteristics						
td(on)	Turn-On Delay Time	VDD = 400V, ID = 10A RG = 20Ω(Note 4)	-	15	-	ns
tr	Turn-On Rise Time		-	11	-	ns
td(off)	Turn-Off Delay Time		-	110	-	ns
tf	Turn-Off Fall Time		-	9	-	ns
Qg	Total Gate Charge	VDS = 480V, ID = 20A VGS = 10V (Note 4)	-	30	-	nC
Qgs	Gate-Source Charge		-	10	-	nC
Qgd	Gate-Drain Charge		-	9	-	nC
Drain-Source Diode Characteristics and Maximum Ratings						
IS	Maximum Continuous Drain-Source Diode Forward Current		-	-	20	A
ISM	Maximum Pulsed Drain-Source Diode Forward Current		-	-	60	A
VSD	Drain-Source Diode Forward Voltage	VGS = 0V, IF = 10A	-	1	1.5	V
trr	Reverse Recovery Time	VR = 480V, IF = 20A diF/dt = 100A/μs	-	500	-	ns
Qrr	Reverse Recovery Charge		-	6	-	μC
Irrm	Peak reverse recovery Current		-	20	-	A

NOTES:

1. Repetitive Rating: Pulse width limited by maximum junction temperature
2. IAS=3.5A, VDD=50V, Starting TJ=25 °C
3. ISD≤ID, di/dt ≤ 200A/us, VDD ≤ BVDS, Starting TJ = 25 °C
4. Essentially Independent of Operating Temperature Typical Characteristics

Typical Performance Characteristics

Power dissipation

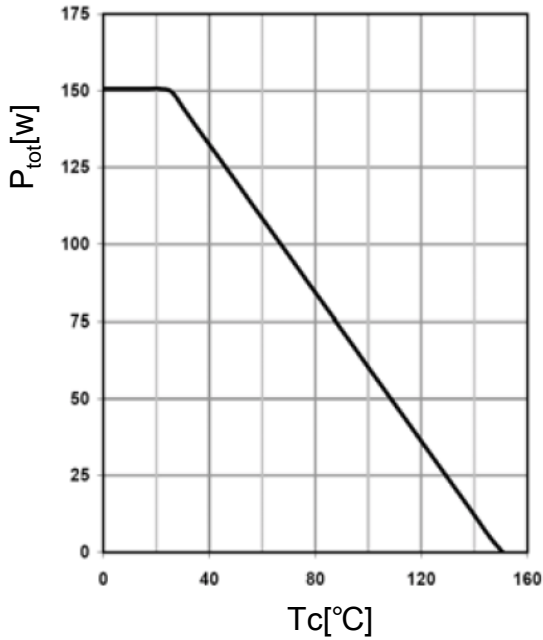

Max. transient thermal impedance

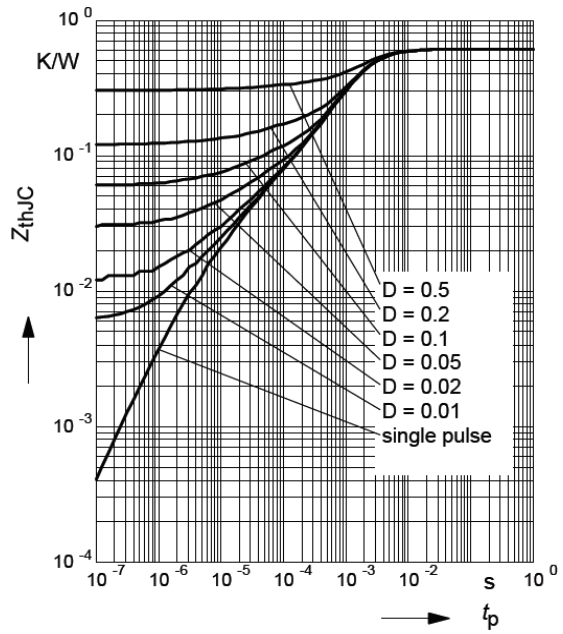

Safe operating area $T_C=25\text{ }^\circ\text{C}$

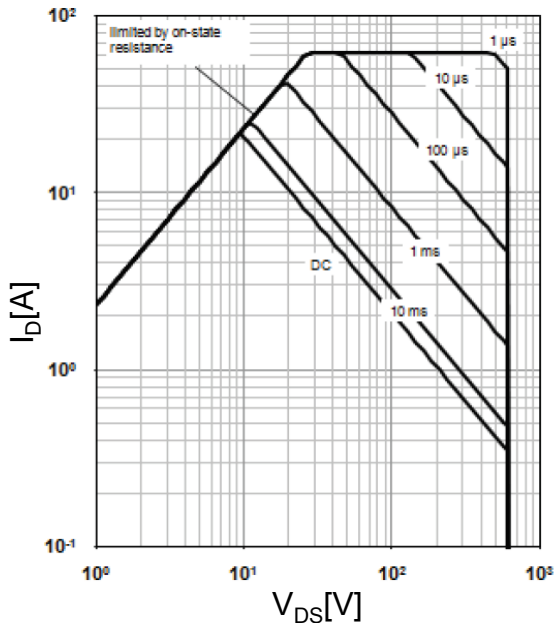

$I_D=f(V_{DS}); T_C=25\text{ }^\circ\text{C}; V_{GS} > 7\text{V}; D=0;$
parameter t_p

Typ. output characteristic

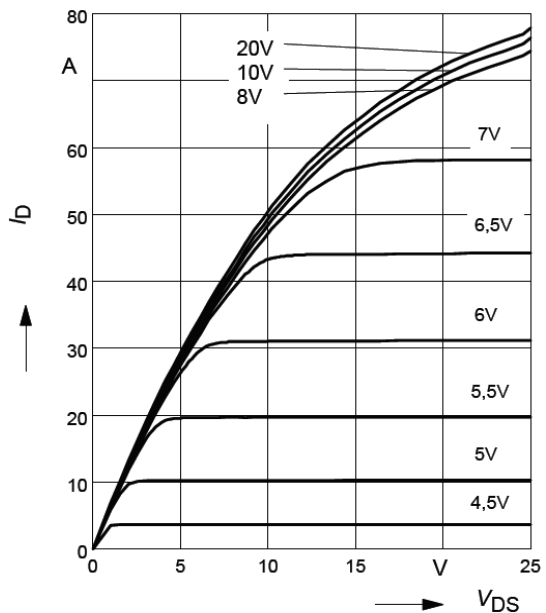

$I_D=f(V_{DS}); T_j=25\text{ }^\circ\text{C};$
parameter $t_p=10\mu\text{s}, V_{GS}$

Typical Performance Characteristics

Typ. output characteristic

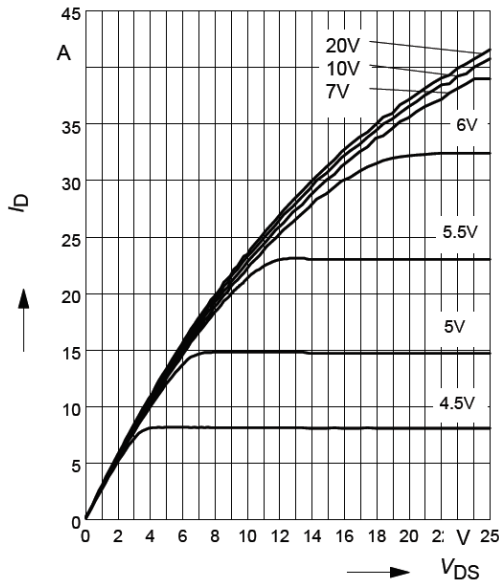

$I_D = f(V_{DS}); T_j = 150\text{ }^\circ\text{C};$
parameter $t_p = 10\mu\text{s}, V_{GS}$

Typ. Drain-Source on resistance

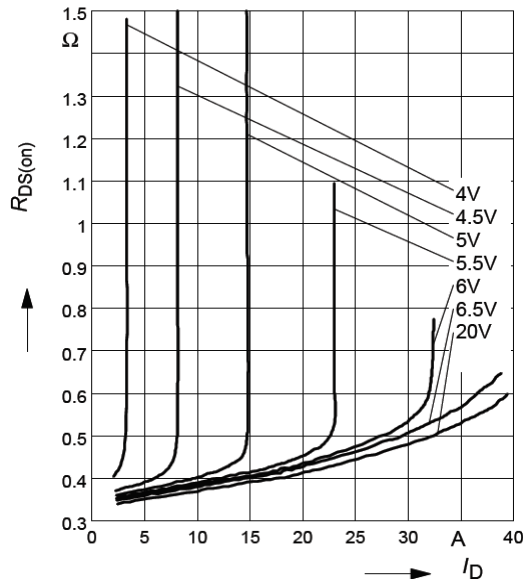

$R_{Dson} = f(I_D); T_j = 150\text{ }^\circ\text{C};$ parameter V_{GS}

Typ. Drain-Source on resistance

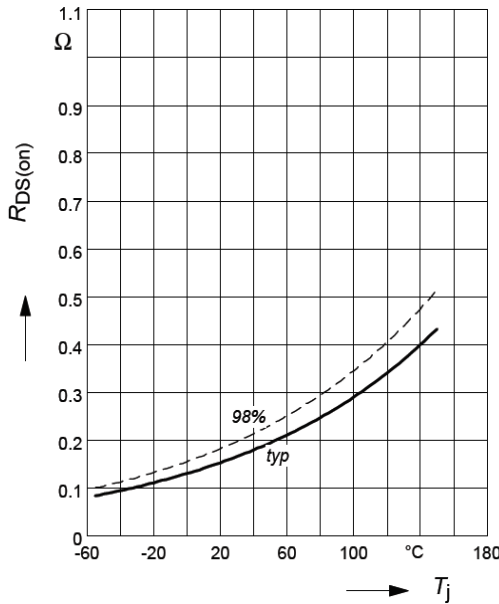

$R_{Dson} = f(T_j); T_j = 150\text{ }^\circ\text{C};$
parameter $I_D = 13.1\text{ A}, V_{GS} = 10\text{ V}$

Typ. Transfer characteristic

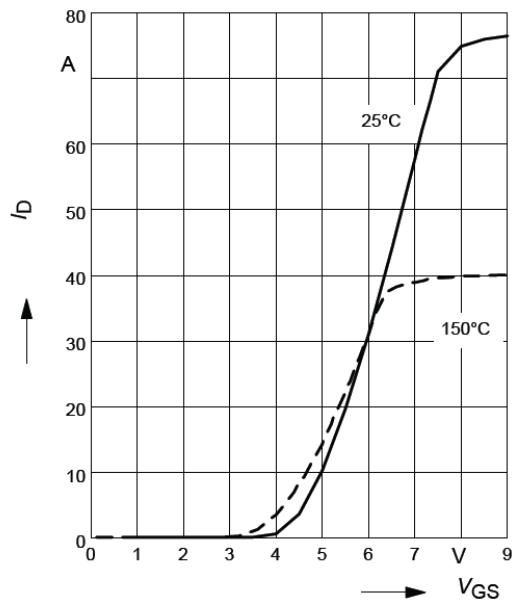

$I_D = f(V_{DS}); V_{DS} > 2 \times I_D \times R_{DS(on)max};$
parameter $t_p = 10\mu\text{s},$

Forward characteristics of reverse diode

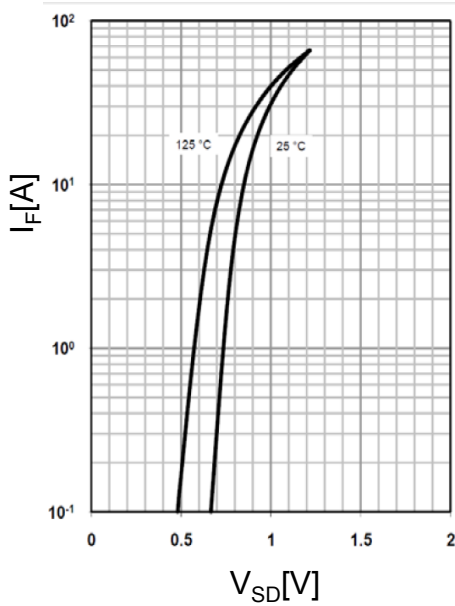

$I_F = f(V_{SD});$ parameter: T_j

Typ. gate charge

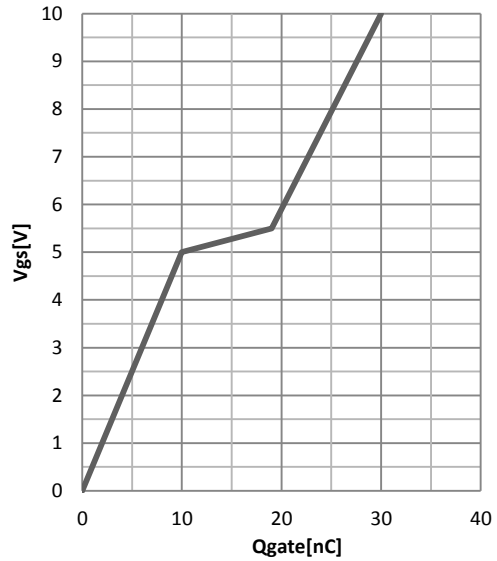

$V_{GS} = f(Q_g), I_D = 20 \text{ A pulsed}$

Avalanche energy

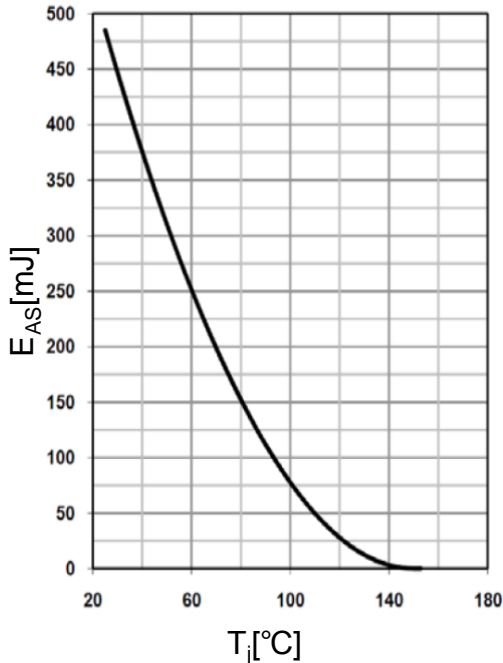

$E_{AS} = f(T_j); I_D = 3.5 \text{ A}; V_{DD} = 50 \text{ V}$

Drain-source breakdown voltage

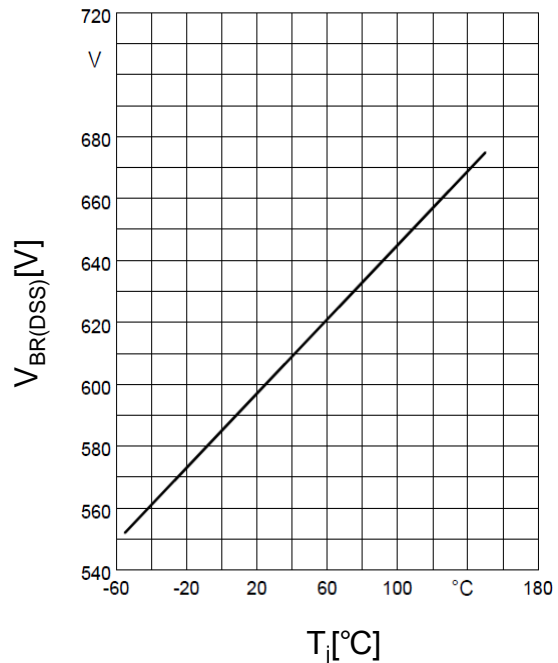

$V_{BR(DSS)} = f(T_j); I_D = 1.0 \text{ mA}$



Typical Performance Characteristics

Typ. capacitances

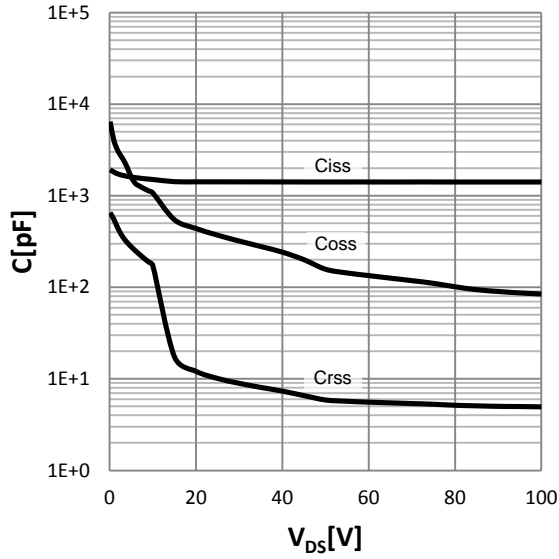

$$C=f(V_{DS}); V_{GS}=0 V; f=1 MHz$$

Typ. Coss stored energy

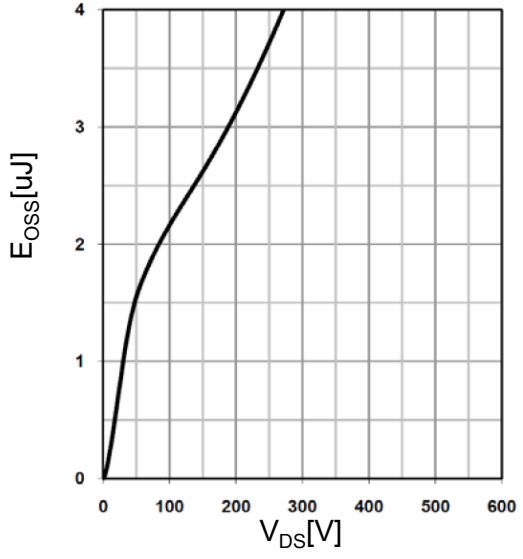

$$E_{oss}=f(V_{DS})$$

Switching times test circuit and waveform for inductive load

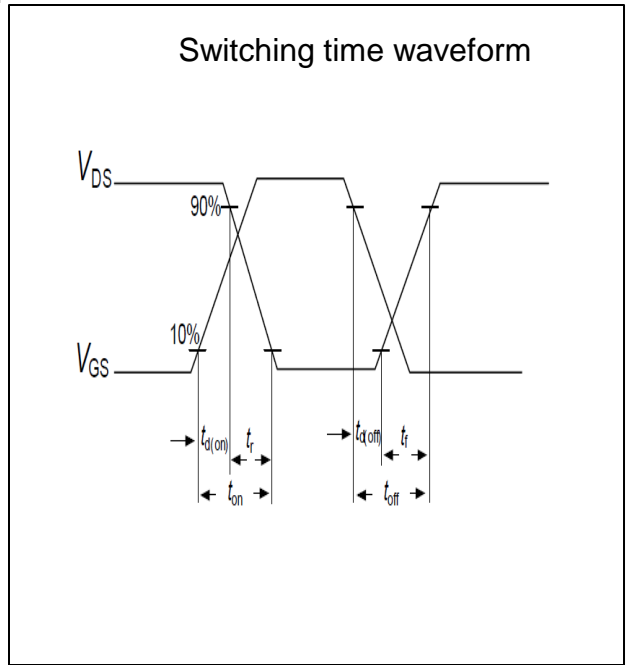
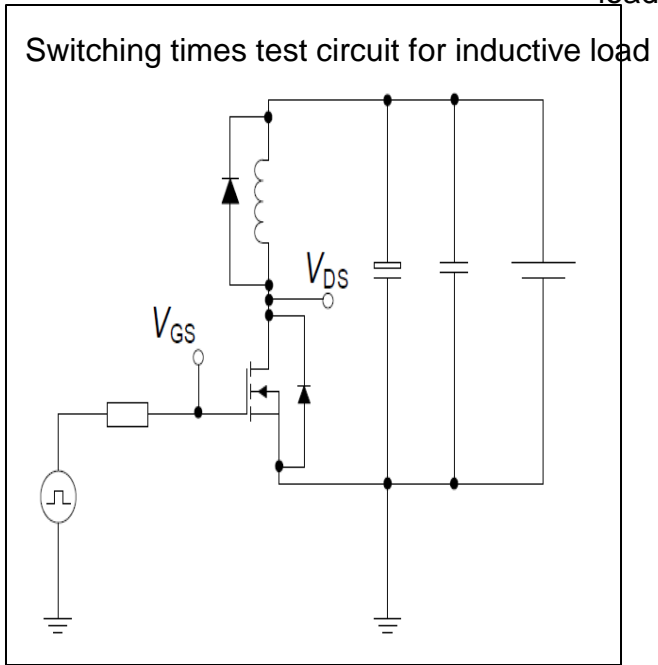

Unclamped inductive load test circuit and waveform

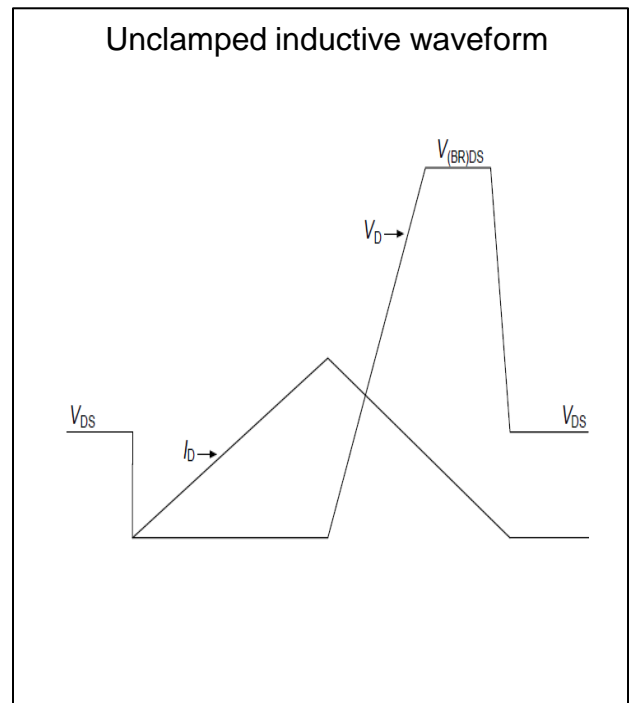
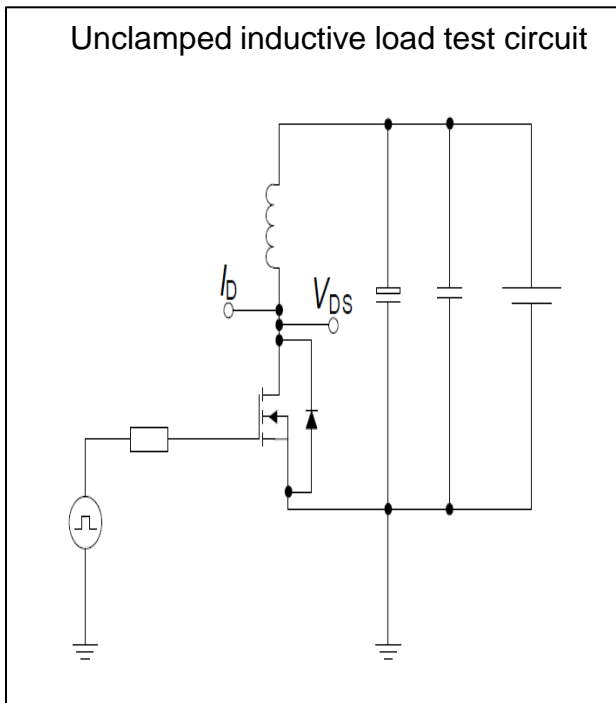

Test circuit and waveform for diode characteristics

Test circuit for diode characteristics

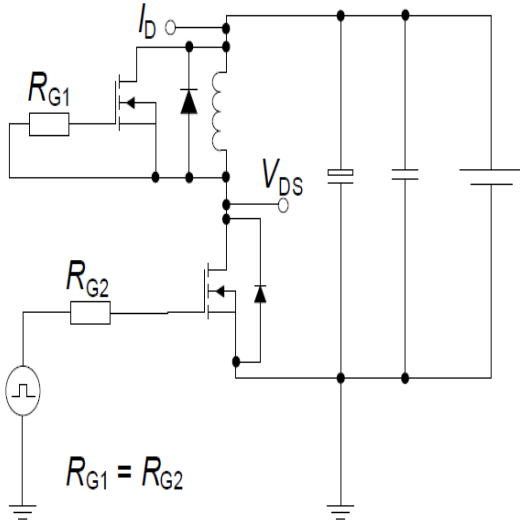

Diode recovery waveform

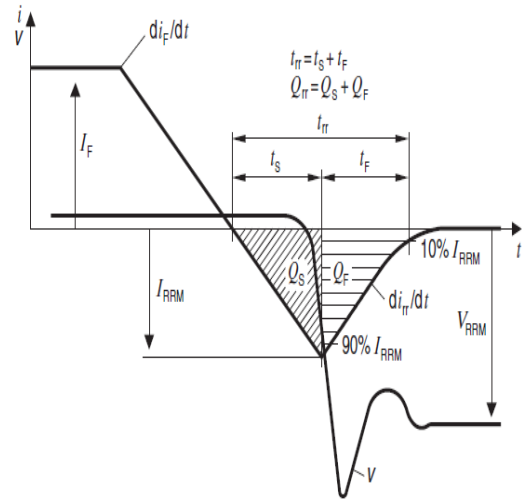

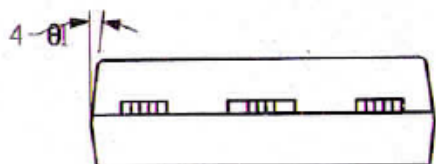
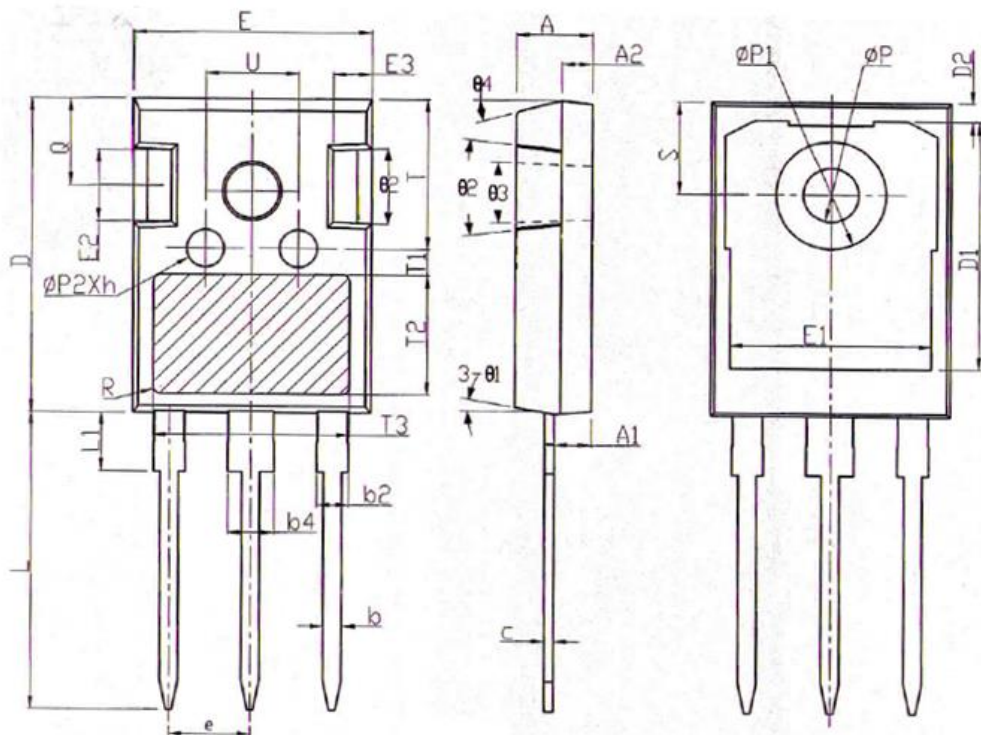

COMMON DIMENSIONS

SYMBOL	MM		
	MIN	NOM	MAX
A	4.90	5.00	5.10
A1	2.31	2.41	2.51
A2	1.90	2.00	2.10
b	1.16	1.21	1.26
b2	1.96	2.01	2.06
b4	2.96	3.01	3.06
c	0.59	0.61	0.66
D	20.90	21.00	21.10
D1	16.25	16.55	16.85
D2	1.05	1.20	1.35
E	15.70	15.80	15.90
E1	13.10	13.30	13.50
E2	4.90	5.00	5.10
E3	2.40	2.50	2.60
e	5.44BSC		
h	0.05	0.10	0.15
L	19.80	19.92	20.10
L1	-	-	4.30
ΦP	3.50	3.60	3.70
$\Phi P1$	-	-	7.30
$\Phi P2$	2.40	2.50	2.60
Q	5.60	5.80	6.00
S	6.15BSC		
R	0.50REF		
T	9.80	-	10.20
T1	1.65REF		
T2	8.00REF		
T3	12.80REF		
U	6.00	-	6.40
$\theta 1$	6°	7°	8°
$\theta 2$	4°	5°	6°
$\theta 3$	1°	-	1.5°
$\theta 4$	14°	15°	16°

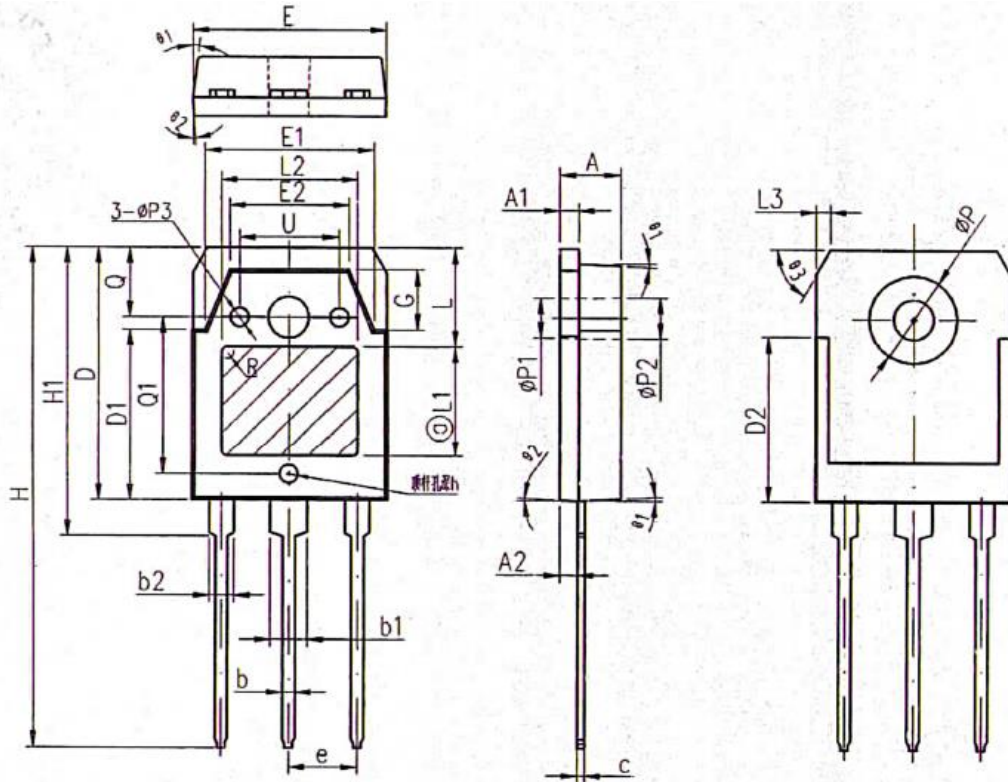

COMMON DIMENSIONS

SYMBOL	MM		
	MIN	NOM	MAX
A	4.60	4.80	5.00
A1	1.40	1.50	1.60
A2	1.33	1.38	1.43
b	0.80	1.00	1.20
b1	2.80	3.00	3.20
b2	1.80	2.00	2.20
c	0.50	0.60	0.70
D	19.75	19.90	20.05
D1	13.70	13.90	14.10
D2	12.90 REF		
E	15.40	15.60	15.80
E1	13.40	13.60	13.80
E2	9.40	9.60	9.80
e	5.45 TYP		
G	4.60	4.80	5.00
H	40.30	40.50	40.70
H1	23.20	23.40	23.60
h	0.05	0.10	0.15
L	7.40 TYP		
L1	9.00 TYP		
L2	11.00 TYP		
L3	1.00 REF		
ΦP	6.90	7.00	7.10
ΦP1	3.20 REF		
ΦP2	3.50 REF		
ΦP3	1.40	1.50	1.60
R	0.50 REF		
Q	5.00 REF		
Q1	12.56	12.76	12.96
U	7.8	8	8.2
θ1	5°	7°	9°
θ2	1°	3°	5°
θ3	60° REF		



DISCLAIMER

SUPER SEMICONDUCTOR reserves the right to make changes WITHOUT further notice to any products herein to improve reliability, function, or design.

For documents and material available from this datasheet, SUPER SEMICONDUCTOR does not warrant or assume any legal liability or responsibility for the accuracy, completeness of any product or technology disclosed hereunder.

The information given in this document shall in no event be regarded as a guarantee of conditions or characteristics. With respect to any examples or hints given herein, any typical values stated herein and/or any information regarding the application of the device, SUPER SEMICONDUCTOR hereby disclaims any and all warranties and liabilities of any kind, including without limitation, warranties of non-infringement of intellectual property rights of any third party.

The products shown herein are not designed for use as critical components in medical, life-saving, or life-sustaining applications, whose failure to perform can be reasonably expected to cause the failure of the life support device or system, or to affect its safety or effectiveness. Customers using or selling SUPER SEMICONDUCTOR products not expressly indicated for use in such applications do so entirely at their own risk and agree to fully indemnify SUPER SEMICONDUCTOR for any damages arising or resulting from such use or sale.

INFORMATION

For further information on technology, delivery terms and conditions and prices, please contact SUPER SEMICONDUCTOR office or website (www.supersemi.com.cn).