

ZL 系列
SERIES

105°C 高纹波电流低阻抗品
105°C High ripple current, Low impedance.

◆ 特 长 / FEATURES

- 实现高频阻抗的降低及高纹波电流化。
Enabled high ripple current by a reduction of impedance at high frequency range.
- 105°C、1000~5000小时品。
Load Life : 105°C 1000~5000hours.
- RoHS指令对应品。
RoHS compliance.

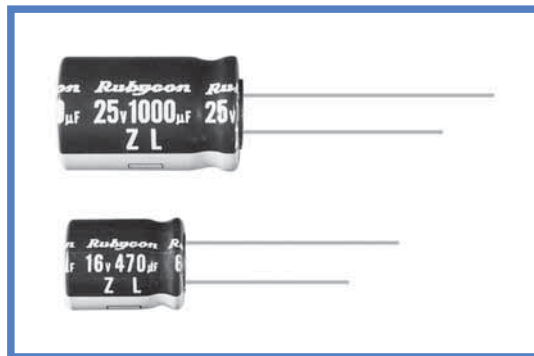

◆ 规格表 / SPECIFICATIONS

项 目 Items	特 性 Characteristics																														
工作温度范围 Category Temperature Range	-40 ~ +105°C																														
额定电压范围 Rated Voltage Range	6.3 ~ 100V.DC																														
静电容量允许差 Capacitance Tolerance	±20% (20°C, 120Hz)																														
漏 电 流 Leakage Current(MAX)	小于I=0.01CV和3µA中的较大值 (施加额定电压2分钟后) I=0.01CV or 3µA whichever is greater. (After 2 minutes) I=漏电流 (µA) C=静电容量 (µF) V=额定电压 (V) Leakage Current Capacitance Rated Voltage																														
损失角正切值 (tan δ) Dissipation Factor(MAX)	<table border="1"> <tr> <td>额定电压 (V) Rated Voltage</td> <td>6.3</td> <td>10</td> <td>16</td> <td>25</td> <td>35</td> <td>50</td> <td>63</td> <td>100</td> <td>(20°C, 120Hz)</td> </tr> <tr> <td>tan δ</td> <td>0.22</td> <td>0.19</td> <td>0.16</td> <td>0.14</td> <td>0.12</td> <td>0.10</td> <td>0.09</td> <td>0.08</td> <td></td> </tr> </table> <p>对于静电容量超过1000µF的产品, 其静电容量每增加1000µF, 则损失角正切值在上表值的基础上加上0.02。 When capacitance is over 1000µF, tan δ shall be added 0.02 to the listed value with increase of every 1000µF.</p>	额定电压 (V) Rated Voltage	6.3	10	16	25	35	50	63	100	(20°C, 120Hz)	tan δ	0.22	0.19	0.16	0.14	0.12	0.10	0.09	0.08											
额定电压 (V) Rated Voltage	6.3	10	16	25	35	50	63	100	(20°C, 120Hz)																						
tan δ	0.22	0.19	0.16	0.14	0.12	0.10	0.09	0.08																							
耐 久 性 Endurance	<p>在105°C环境中, 不超过额定电压的范围内叠加额定纹波电流, 连续加载右表时间后, 满足以下各项要求。 After life test with rated ripple current at conditions stated in the table below at 105°C, the capacitors shall meet the following requirements.</p> <table border="1"> <tr> <td>静电容量变化率 Capacitance Change</td> <td>初期值的±25%以内 Within ±25% of the initial value.</td> <td rowspan="3"> <table border="1"> <tr> <td>铝壳尺寸 Case Size</td> <td>时间 (hrs) Life Time</td> </tr> <tr> <td>L=7</td> <td>1000</td> </tr> <tr> <td rowspan="4">L≥11</td> <td>φD≤6.3</td> <td>2000</td> </tr> <tr> <td>φD=8</td> <td>3000</td> </tr> <tr> <td>φD=10</td> <td>4000</td> </tr> <tr> <td>φD≥12.5</td> <td>5000</td> </tr> </table> </td> </tr> <tr> <td>损失角正切值 Dissipation Factor</td> <td>规格值的200%以下 Not more than 200% of the specified value.</td> </tr> <tr> <td>漏 电 流 Leakage Current</td> <td>规格值以下 Not more than the specified value.</td> </tr> </table>	静电容量变化率 Capacitance Change	初期值的±25%以内 Within ±25% of the initial value.	<table border="1"> <tr> <td>铝壳尺寸 Case Size</td> <td>时间 (hrs) Life Time</td> </tr> <tr> <td>L=7</td> <td>1000</td> </tr> <tr> <td rowspan="4">L≥11</td> <td>φD≤6.3</td> <td>2000</td> </tr> <tr> <td>φD=8</td> <td>3000</td> </tr> <tr> <td>φD=10</td> <td>4000</td> </tr> <tr> <td>φD≥12.5</td> <td>5000</td> </tr> </table>	铝壳尺寸 Case Size	时间 (hrs) Life Time	L=7	1000	L≥11	φD≤6.3	2000	φD=8	3000	φD=10	4000	φD≥12.5	5000	损失角正切值 Dissipation Factor	规格值的200%以下 Not more than 200% of the specified value.	漏 电 流 Leakage Current	规格值以下 Not more than the specified value.										
静电容量变化率 Capacitance Change	初期值的±25%以内 Within ±25% of the initial value.	<table border="1"> <tr> <td>铝壳尺寸 Case Size</td> <td>时间 (hrs) Life Time</td> </tr> <tr> <td>L=7</td> <td>1000</td> </tr> <tr> <td rowspan="4">L≥11</td> <td>φD≤6.3</td> <td>2000</td> </tr> <tr> <td>φD=8</td> <td>3000</td> </tr> <tr> <td>φD=10</td> <td>4000</td> </tr> <tr> <td>φD≥12.5</td> <td>5000</td> </tr> </table>	铝壳尺寸 Case Size		时间 (hrs) Life Time	L=7	1000	L≥11		φD≤6.3	2000	φD=8	3000	φD=10	4000	φD≥12.5	5000														
铝壳尺寸 Case Size	时间 (hrs) Life Time																														
L=7	1000																														
L≥11	φD≤6.3	2000																													
	φD=8	3000																													
	φD=10	4000																													
	φD≥12.5	5000																													
损失角正切值 Dissipation Factor	规格值的200%以下 Not more than 200% of the specified value.																														
漏 电 流 Leakage Current	规格值以下 Not more than the specified value.																														
低 温 特 性 Low Temperature Stability (阻抗比) Impedance Ratio(MAX)	<table border="1"> <tr> <td>额定电压 (V) Rated Voltage</td> <td>6.3</td> <td>10</td> <td>16</td> <td>25</td> <td>35</td> <td>50</td> <td>63</td> <td>100</td> <td>(120Hz)</td> </tr> <tr> <td>Z(-25°C)/Z(20°C)</td> <td>2</td> <td>2</td> <td>2</td> <td>2</td> <td>2</td> <td>2</td> <td>2</td> <td>2</td> <td></td> </tr> <tr> <td>Z(-40°C)/Z(20°C)</td> <td>3</td> <td>3</td> <td>3</td> <td>3</td> <td>3</td> <td>3</td> <td>3</td> <td>3</td> <td></td> </tr> </table>	额定电压 (V) Rated Voltage	6.3	10	16	25	35	50	63	100	(120Hz)	Z(-25°C)/Z(20°C)	2	2	2	2	2	2	2	2		Z(-40°C)/Z(20°C)	3	3	3	3	3	3	3	3	
额定电压 (V) Rated Voltage	6.3	10	16	25	35	50	63	100	(120Hz)																						
Z(-25°C)/Z(20°C)	2	2	2	2	2	2	2	2																							
Z(-40°C)/Z(20°C)	3	3	3	3	3	3	3	3																							

◆ 尺寸图 / DIMENSIONS (mm)

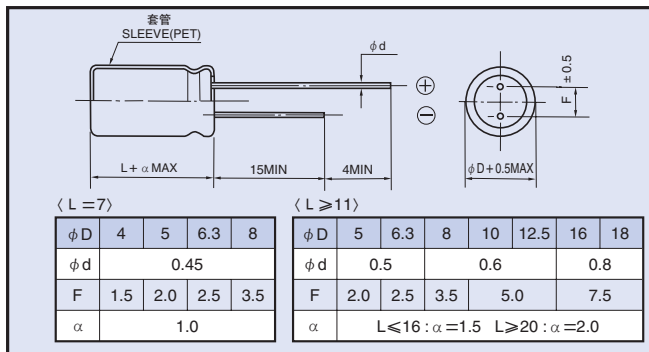

◆ 纹波电流修正系数 /

MULTIPLIER FOR RIPPLE CURRENT

频率系数 Frequency Coefficient

频率 (Hz) Frequency		120	1k	10k	100k≤
系 数 Coefficient	5.6 ~ 33µF	0.42	0.70	0.90	1.00
	39 ~ 270µF	0.50	0.73	0.92	1.00
	330 ~ 680µF	0.55	0.77	0.94	1.00
	820 ~ 1800µF	0.60	0.80	0.96	1.00
	2200 ~ 6800µF	0.70	0.85	0.98	1.00

◆ 副记号 / OPTION

	记号 Code
PET套管 PET Sleeve	EFC

◆ 产品型号体系 / PART NUMBER

□□□	ZL	□□□□□	M	□□□	□□	D×L
额定电压 Rated Voltage	系列名称 Series	静电容量 Capacitance	静电容量允许差 Capacitance Tolerance	副记号 Option	引线加工记号 Lead Forming	铝壳尺寸 Case Size

◆标准品一览表 / STANDARD SIZE

额定电压 Rated Voltage (V · DC)	静电容量 Capacitance (μF)	外形尺寸 Size φ D×L(mm)	额定纹波电流 Rated ripple current (mA r.m.s./105°C, 100kHz)	阻抗 (Ω MAX) Impedance	
				20°C, 100kHz	-10°C, 100kHz
6.3 (0J)	39	4×7	130	0.85	2.6
	68	5×7	210	0.43	1.3
	150	6.3×7	300	0.23	0.69
	150	5×11	250	0.30	1.0
	220	8×7	380	0.15	0.45
	330	6.3×11	405	0.13	0.41
	560	8×11.5	760	0.072	0.22
	820	8×16	995	0.056	0.17
	1000	10×12.5	1030	0.053	0.16
	1200	8×20	1250	0.041	0.13
	1200	10×16	1430	0.038	0.12
	1500	10×20	1820	0.023	0.069
	2200	10×23	2150	0.022	0.066
	3300	12.5×20	2360	0.021	0.053
	3900	12.5×25	2770	0.018	0.045
	4700	12.5×30	3290	0.016	0.041
5600	12.5×35	3400	0.015	0.039	
5600	16×20	3140	0.018	0.045	
6800	16×25	3460	0.016	0.043	
10 (1A)	27	4×7	130	0.89	2.7
	56	5×7	210	0.44	1.4
	100	5×11	250	0.30	1.0
	120	6.3×7	300	0.23	0.69
	180	8×7	380	0.15	0.45
	220	6.3×11	405	0.13	0.41
	470	8×11.5	760	0.072	0.22
	680	8×16	995	0.056	0.17
	680	10×12.5	1030	0.053	0.16
	1000	8×20	1250	0.041	0.13
	1000	10×16	1430	0.038	0.12
	1200	10×20	1820	0.023	0.069
	1500	10×23	2150	0.022	0.066
	2200	12.5×20	2360	0.021	0.053
	3300	12.5×25	2770	0.018	0.045
	3900	12.5×30	3290	0.016	0.041
3900	16×20	3140	0.018	0.045	
4700	12.5×35	3400	0.015	0.039	
5600	16×25	3460	0.016	0.043	
16 (1C)	18	4×7	130	0.92	2.8
	33	5×7	210	0.45	1.4
	56	5×11	250	0.30	1.0
	68	6.3×7	300	0.24	0.72
	120	8×7	380	0.15	0.45
	120	6.3×11	405	0.13	0.41
	330	8×11.5	760	0.072	0.22
	470	8×16	995	0.056	0.17
	470	10×12.5	1030	0.053	0.16
	680	8×20	1250	0.041	0.13
	680	10×16	1430	0.038	0.12
	1000	10×20	1820	0.023	0.069
	1200	10×23	2150	0.022	0.066
	1500	12.5×20	2360	0.021	0.053
	2200	12.5×25	2770	0.018	0.045
	2700	12.5×30	3290	0.016	0.041
2700	16×20	3140	0.018	0.045	
3300	12.5×35	3400	0.015	0.039	
3900	16×25	3460	0.016	0.043	
25 (1E)	15	4×7	130	0.94	2.9
	27	5×7	210	0.46	1.4
	47	5×11	250	0.30	1.0
	56	6.3×7	300	0.24	0.72
	100	8×7	380	0.15	0.45
	100	6.3×11	405	0.13	0.41
	220	8×11.5	760	0.072	0.22
	330	8×16	995	0.056	0.17
	330	10×12.5	1030	0.053	0.16
	470	8×20	1250	0.041	0.13
	470	10×16	1430	0.038	0.12
	680	10×20	1820	0.023	0.069
	820	10×23	2150	0.022	0.066
	1000	12.5×20	2360	0.021	0.053
	1500	12.5×25	2770	0.018	0.045
	1800	12.5×30	3290	0.016	0.041
1800	16×20	3140	0.018	0.045	
2200	12.5×35	3400	0.015	0.039	
2700	16×25	3460	0.016	0.043	

◆标准品一览表 / STANDARD SIZE

额定电压 Rated Voltage (V · DC)	静电容量 Capacitance (μF)	外形尺寸 Size φ D×L(mm)	额定纹波电流 Rated ripple current (mA r.m.s./105°C, 100kHz)	阻抗 (Ω MAX) Impedance	
				20°C, 100kHz	-10°C, 100kHz
35 (1V)	10	4×7	130	0.96	2.9
	18	5×7	210	0.47	1.5
	33	5×11	250	0.30	1.0
	39	6.3×7	300	0.25	0.75
	56	8×7	380	0.16	0.48
	56	6.3×11	405	0.13	0.41
	150	8×11.5	760	0.072	0.22
	220	8×16	995	0.056	0.17
	220	10×12.5	1030	0.053	0.16
	270	8×20	1250	0.041	0.13
	330	10×16	1430	0.038	0.12
	470	10×20	1820	0.023	0.069
	560	10×23	2150	0.022	0.066
	680	12.5×20	2360	0.021	0.053
	1000	12.5×25	2770	0.018	0.045
	1200	12.5×30	3290	0.016	0.041
1200	16×20	3140	0.018	0.045	
1500	12.5×35	3400	0.015	0.039	
1800	16×25	3460	0.016	0.043	
50 (1H)	5.6	4×7	130	1.0	3.0
	10	5×7	210	0.50	1.5
	22	6.3×7	300	0.26	0.78
	22	5×11	238	0.34	1.18
	33	8×7	380	0.17	0.51
	56	6.3×11	385	0.14	0.50
	100	8×11.5	724	0.074	0.22
	120	8×16	950	0.061	0.18
	150	10×12.5	979	0.061	0.18
	180	8×20	1190	0.046	0.14
	220	10×16	1370	0.042	0.12
	270	10×20	1580	0.030	0.090
	330	10×23	1870	0.028	0.085
	470	12.5×20	2050	0.027	0.068
	560	12.5×25	2410	0.023	0.059
	680	12.5×30	2860	0.021	0.052
820	12.5×35	2960	0.019	0.051	
820	16×20	2730	0.023	0.059	
1000	16×25	3010	0.021	0.056	

额定电压 Rated Voltage (V · DC)	静电容量 Capacitance (μF)	外形尺寸 Size φ D×L(mm)	额定纹波电流 Rated ripple current (mA r.m.s./105°C, 100kHz)	阻抗 (Ω MAX) Impedance	
				20°C, 100kHz	-10°C, 100kHz
63 (1J)	15	5×11	165	0.88	3.5
	33	6.3×11	265	0.35	1.4
	56	8×11.5	500	0.22	0.88
	82	8×16	665	0.16	0.64
	82	10×12.5	685	0.15	0.60
	120	8×20	820	0.12	0.48
	120	10×16	945	0.11	0.44
	180	10×20	1100	0.080	0.32
	180	12.5×16	1135	0.082	0.27
	220	10×23	1300	0.073	0.29
	270	12.5×20	1495	0.060	0.20
	330	12.5×25	1850	0.043	0.14
	470	12.5×30	2250	0.039	0.13
	470	16×20	1990	0.045	0.14
	560	12.5×35	2450	0.033	0.11
	560	16×25	2550	0.032	0.096
	680	12.5×40	2780	0.029	0.096
	680	18×20	2450	0.038	0.10
	820	16×31.5	2810	0.026	0.078
	820	18×25	2780	0.031	0.084
	1000	16×35.5	2835	0.021	0.063
1000	18×31.5	3270	0.025	0.068	
1200	16×40	3340	0.019	0.057	
1200	18×35.5	3310	0.020	0.054	
1500	18×40	3420	0.018	0.049	
100 (2A)	6.8	5×11	125	1.4	5.6
	15	6.3×11	205	0.57	2.3
	27	8×11.5	355	0.36	1.4
	39	8×16	450	0.25	1.0
	47	10×12.5	450	0.24	0.96
	56	8×20	565	0.19	0.76
	68	10×16	580	0.18	0.72
	82	10×20	750	0.13	0.52
	82	12.5×16	735	0.13	0.43
	100	10×23	880	0.12	0.48
	120	12.5×20	1045	0.094	0.31
	180	12.5×25	1195	0.071	0.23
	220	12.5×30	1410	0.063	0.21
	220	16×20	1295	0.071	0.21
	270	12.5×35	1560	0.052	0.17
	270	16×25	1600	0.053	0.16
	270	18×20	1470	0.069	0.19
	330	12.5×40	1700	0.046	0.15
	390	16×31.5	1750	0.041	0.12
	390	18×25	1620	0.049	0.13
	470	16×35.5	1890	0.033	0.10
470	18×31.5	1775	0.039	0.11	
560	16×40	2080	0.030	0.090	
560	18×35.5	2060	0.031	0.084	
680	18×40	2570	0.028	0.076	