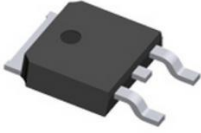
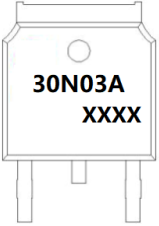
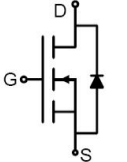

# 30N03A

## 30V N-Channel Power

<p><b>Mosfet</b></p> <p><b>General Description</b></p> <p>These N-channel enhancement mode power mosfets used advanced trench technology design, provided excellent R<sub>ds(on)</sub> and low gate charge. Which accords with the RoHS standard.</p> <p><b>Features</b></p> <ul style="list-style-type: none"> <li>● V<sub>DS</sub> = 30V, I<sub>D</sub> =90A</li> <li>● R<sub>ds(ON)</sub>, 3.9 mΩ (Typ) @ V<sub>GS</sub> =10V</li> <li>● R<sub>ds(ON)</sub>, 6.5mΩ (Typ) @ V<sub>GS</sub> =4.5V</li> <li>● Low on resistance</li> <li>● Low gate charge</li> <li>● Fast switching</li> <li>● Low reverse transfer capacitances</li> </ul> <p><b>Application</b></p> <ul style="list-style-type: none"> <li>● DC-DC converters</li> <li>● Synchronous Rectifier</li> </ul>	 <p>TO-252(DPAK) top view</p>  <p>Marking and pin Assignment</p>  <p>Schematic Diagram</p>
------------------------------------------------------------------------------------------------------------------------------------------------------------------------------------------------------------------------------------------------------------------------------------------------------------------------------------------------------------------------------------------------------------------------------------------------------------------------------------------------------------------------------------------------------------------------------------------------------------------------------------------------------------------------------------------------------------------------------------------------------------------------------	------------------------------------------------------------------------------------------------------------------------------------------------------------------------------------------------------------------------------------------------------------------------------------------------------------------------------------------------------

### Package Marking and Ordering Information

Device Marking	Device	Device Package	Reel Size	Tape width	Quantity
30N03A	30N03A	TO-252	330mm	12mm	2500

### Absolute Maximum Ratings(TA=25°C unless otherwise noted)

Parameter	Symbol	Value	Unit
Drain-Source Voltage	V <sub>DS</sub>	30	V
Gate-Source Voltage	V <sub>GS</sub>	±20	V
Drain Current-Continuous <sup>Note3</sup>	I <sub>D</sub>	TC=25°C	90
		TC=100°C	63
Drain Current-Pulsed <sup>Note1</sup>	I <sub>DM</sub>	200	A
Avalanche Energy <sup>Note4</sup>	E <sub>AS</sub>	280	mJ
Avalanche Current	I <sub>AS</sub>	33	A
Maximum Power Dissipation	P <sub>D</sub>	105	W
Storage Temperature Range	T <sub>STG</sub>	-55 to +150	°C
Operating Junction Temperature Range	T <sub>J</sub>	-55 to +150	°C

### Thermal Resistance

Parameter	Symbol	Min.	Typ.	Max	Unit
Thermal Resistance, Junction-to-Case	R <sub>θJC</sub>	-	3.3	-	°C/W

**Electrical Characteristics(T<sub>J</sub>=25°C unless otherwise noted)**

OFF CHARACTERISTICS						
Parameter	Symbol	Conditions	Min.	Typ.	Max.	Unit
Drain-Source Breakdown Voltage	BV <sub>DSS</sub>	V <sub>GS</sub> =0V, I <sub>DS</sub> =250uA	30	-	-	V
Zero Gate Voltage Drain Current	I <sub>DSS</sub>	V <sub>DS</sub> =30V, V <sub>GS</sub> =0V	-	-	1	uA
Gate-Body Leakage	I <sub>GSS</sub>	V <sub>GS</sub> =±20V, V <sub>DS</sub> =0V	-	-	±100	nA

ON CHARACTERISTICS						
Parameter	Symbol	Conditions	Min.	Typ.	Max.	Unit
Gate Threshold Voltage	V <sub>GS(TH)</sub>	V <sub>DS</sub> =V <sub>GS</sub> , I <sub>DS</sub> =250uA	1.0	1.7	2.5	V
Drain-Source On-State Resistance	R <sub>DS(ON)</sub>	V <sub>GS</sub> =10V, I <sub>DS</sub> =30A	-	3.9	5.0	mΩ
		V <sub>GS</sub> =4.5V, I <sub>DS</sub> =20A	-	6.5	8.0	

DYNAMIC CHARACTERISTICS						
Parameter	Symbol	Conditions	Min.	Typ.	Max.	Unit
Input Capacitance	C <sub>ISS</sub>	V <sub>DS</sub> = 15V, V <sub>GS</sub> = 0V, f=1MHz	-	1963	-	pF
Output Capacitance	C <sub>OSS</sub>		-	248	-	
Reverse Transfer Capacitance	C <sub>rss</sub>		-	221	-	
Gate Resisitance	R <sub>g</sub>	V <sub>DD</sub> =0V, V <sub>GS</sub> =1V, F=1MHz	-	1.43	-	Ω

SWITCHING CHARACTERISTICS						
Parameter	Symbol	Conditions	Min.	Typ.	Max.	Unit
Turn-On Delay Time	T <sub>d(on)</sub>	V <sub>GS</sub> =10V, V <sub>DS</sub> =15V, R <sub>GEN</sub> =3Ω I <sub>D</sub> =20A	-	55	-	ns
Rise Time	t <sub>r</sub>		-	36.4	-	
Turn-Off Delay Time	T <sub>d(off)</sub>		-	37.5	-	
Fall Time	t <sub>f</sub>		-	14	-	
Total Gate Charge at 10V	Q <sub>g</sub>	V <sub>DS</sub> =15V, I <sub>DS</sub> =45A, V <sub>GS</sub> =10V	-	41	-	nC
Gate to Source Gate Charge	Q <sub>gs</sub>		-	6.4	-	
Gate to Drain "Miller" Charge	Q <sub>gd</sub>		-	11	-	

DRAIN-SOURCE DIODE CHARACTERISTICS AND MAXIMUM RATINGS						
Parameter	Symbol	Conditions	Min.	Typ.	Max.	Unit
Drain-Source Diode Forward Voltage	V <sub>SD</sub>	V <sub>GS</sub> =0V, I <sub>DS</sub> =20A	-	-	1.2	V
Reverse Recovery Time	t <sub>rr</sub>	T <sub>J</sub> =25°C, I <sub>F</sub> =20A	-	21.7	-	nS
Reverse Recovery Charge	Q <sub>rr</sub>	di/dt=100A/us	-	7.2	-	nC

**Notes:**

- 1: Repetitive rating, pulse width limited by maximum junction temperature.
- 2: Surface mounted on FR4 Board, t<sub>s</sub>≤10sec.
- 3: Pulse width ≤ 300μs, duty cycle ≤ 2%.
- 4: EAS condition: L=0.5mH, V<sub>DD</sub>=15V, V<sub>G</sub>=10V, V<sub>GATE</sub>=30V, Start T<sub>J</sub>=25°C.

**Test Circuit**

1) E<sub>AS</sub> Test Circuit

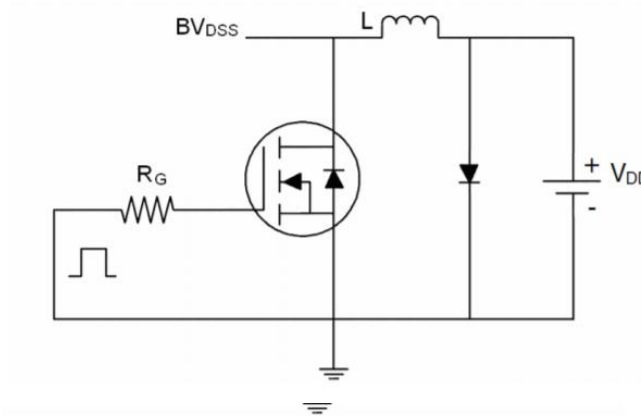

2) Gate Charge Test Circuit

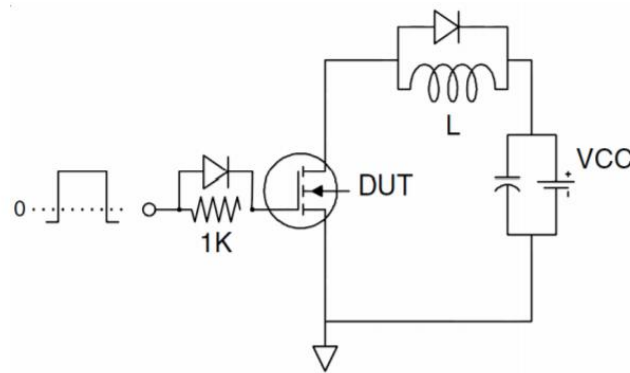

3) Switch Time Test Circuit

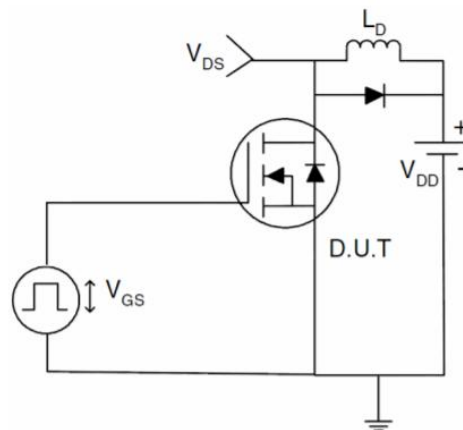

Typical Electrical and Thermal Characteristics (Curves)

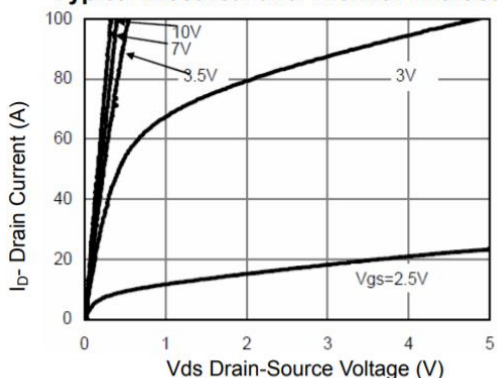

Figure 1 Output Characteristics

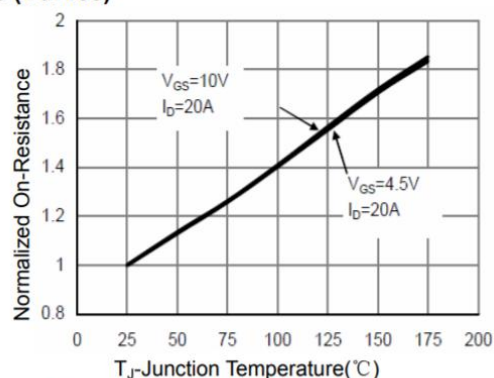

Figure 4  $R_{ds(on)}$ -Junction Temperature

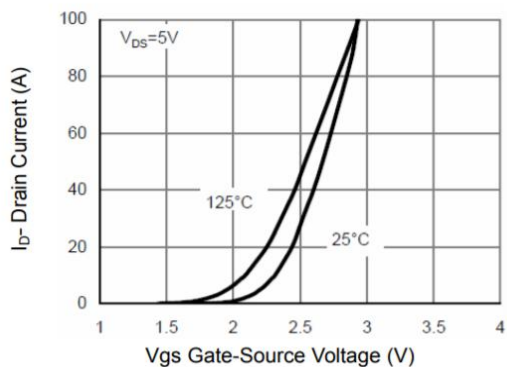

Figure 2 Transfer Characteristics

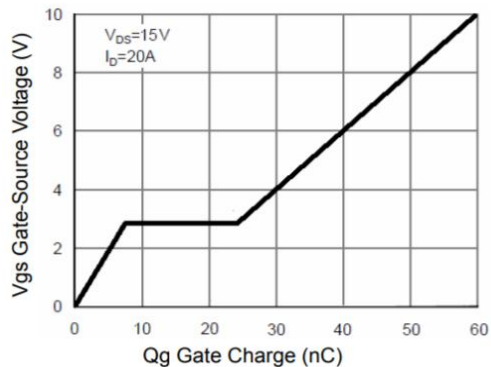

Figure 5 Gate Charge

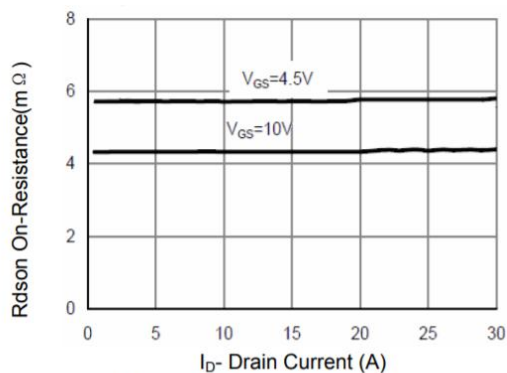

Figure 3  $R_{ds(on)}$ - Drain Current

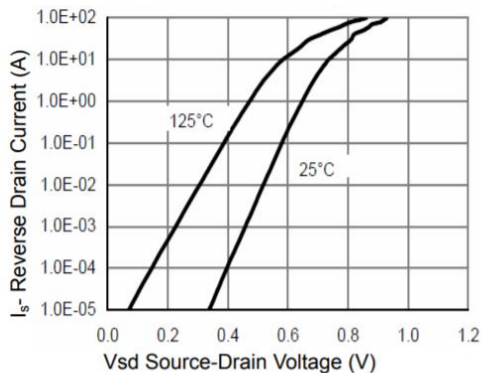
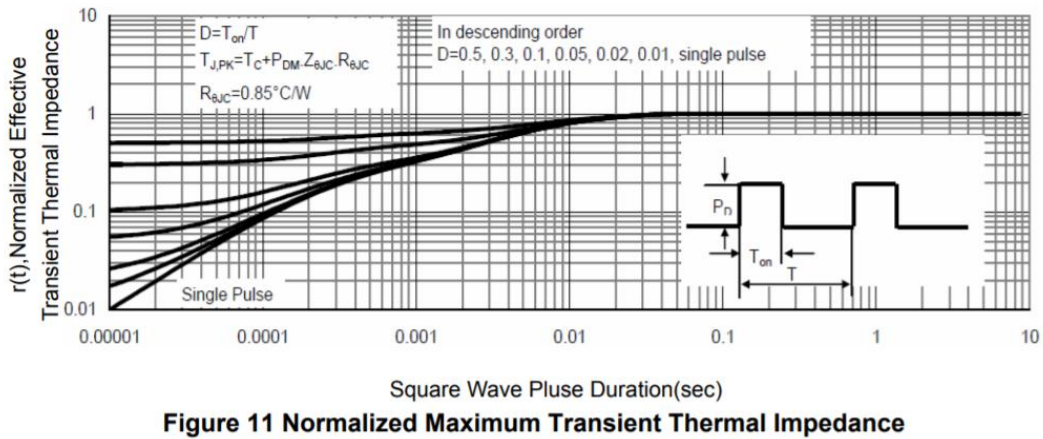
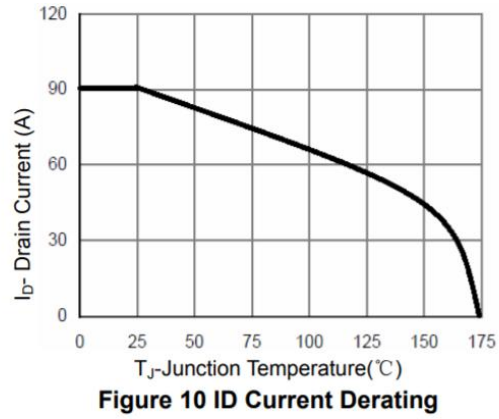
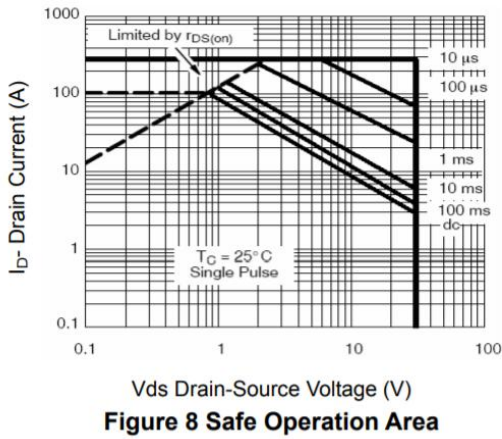
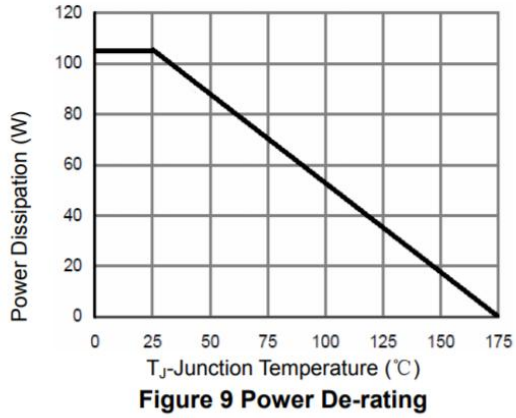
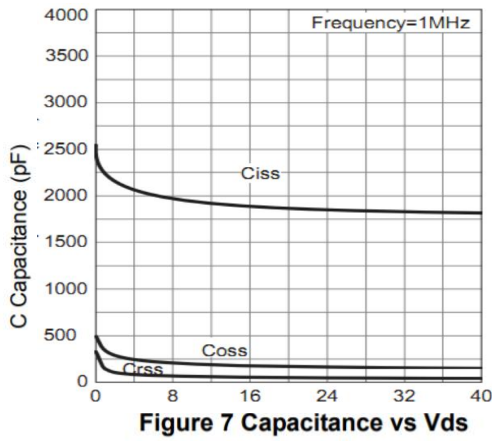
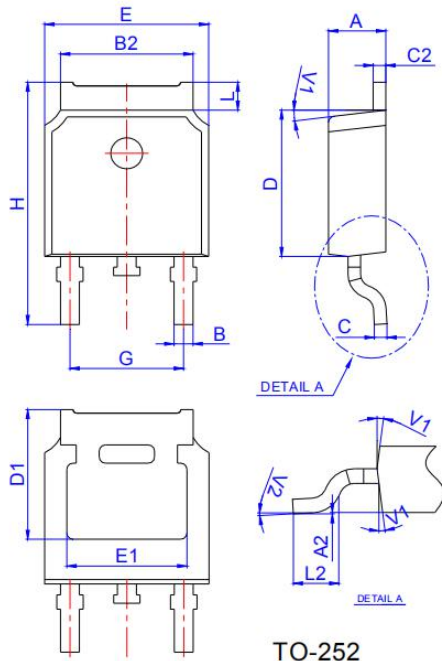

Figure 6 Source- Drain Diode Forward



**Package Mechanical Data**



Ref.	Dimensions					
	Millimeters			Inches		
	Min.	Typ.	Max.	Min.	Typ.	Max.
A	2.10		2.50	0.083		0.098
A2	0		0.10	0		0.004
B	0.66		0.86	0.026		0.034
B2	5.18		5.48	0.202		0.216
C	0.40		0.60	0.016		0.024
C2	0.44		0.58	0.017		0.023
D	5.90		6.30	0.232		0.248
D1	5.30REF			0.209REF		
E	6.40		6.80	0.252		0.268
E1	4.63			0.182		
G	4.47		4.67	0.176		0.184
H	9.50		10.70	0.374		0.421
L	1.09		1.21	0.043		0.048
L2	1.35		1.65	0.053		0.065
V1		7°			7°	
V2	0°		6°	0°		6°

**Reel Specification-TO-252**

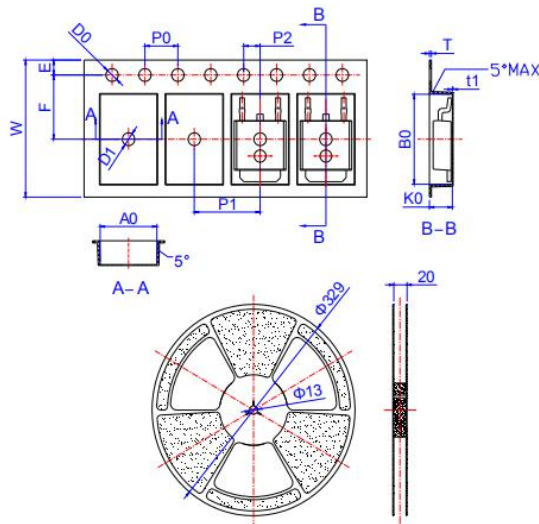

Ref.	Dimensions					
	Millimeters			Inches		
	Min.	Typ.	Max.	Min.	Typ.	Max.
W	15.90	16.00	16.10	0.626	0.630	0.634
E	1.65	1.75	1.85	0.065	0.069	0.073
F	7.40	7.50	7.60	0.291	0.295	0.299
D0	1.40	1.50	1.60	0.055	0.059	0.063
D1	1.40	1.50	1.60	0.055	0.059	0.063
P0	3.90	4.00	4.10	0.154	0.157	0.161
P1	7.90	8.00	8.10	0.311	0.315	0.319
P2	1.90	2.00	2.10	0.075	0.079	0.083
A0	6.85	6.90	7.00	0.270	0.271	0.276
B0	10.45	10.50	10.60	0.411	0.413	0.417
K0	2.68	2.78	2.88	0.105	0.109	0.113
T	0.24		0.27	0.009		0.011
t1	0.10			0.004		
10P0	39.80	40.00	40.20	1.567	1.575	1.583

DWG NO: TO-252-01-A1	TITLE TO-252	SCALE	
		4:1	
SHEET	1 OF 1		