

微孔型超音波霧化片驅動晶片

概述

TTP320-AO8 IC 為一款驅動晶片，專門用於微孔型超音波霧化片，裝置內建調整輸出功率，自動掃描霧樺片共振頻率，且有通信接口可供功能設定(過載保護、無水判斷、PWM Duty 設定、掃頻)。

特點

- 晶片工作電壓 2.4V ~ 5.5V
- 待機典型工作電流, 無負載 < 2.0uA@VDD=5V(停機)
- 微孔型霧化片適用中心共振頻率範圍 90KHz ~180KHz (需搭配外部電阻)
自動調整共振頻率範圍 $\pm 15\%$
- 待機省電功能可用於電池供電
- 提供通信接口設定功能
- 提供 MCU 通信接口功能設定
- MCU 可經由 ADC 讀取 ISEN 電壓可以實現“過載保護”與“無水判斷”
- MCU 可經由晶片內建暫存器設定 PWM “占空比”與“頻率”
- 內建 LVD 3.2V (精準度 $\pm 5\%$)

應用範圍

- 各種消費性產品霧化加濕器或霧化器

IC 腳位圖

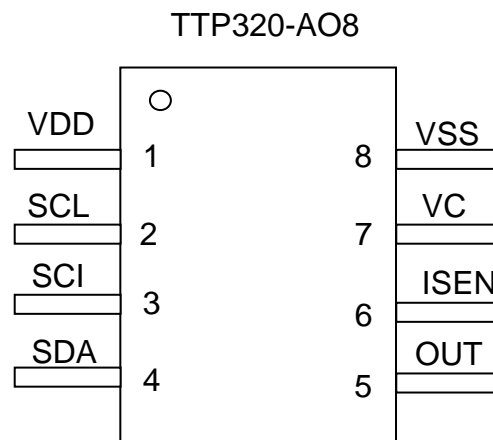

方塊圖

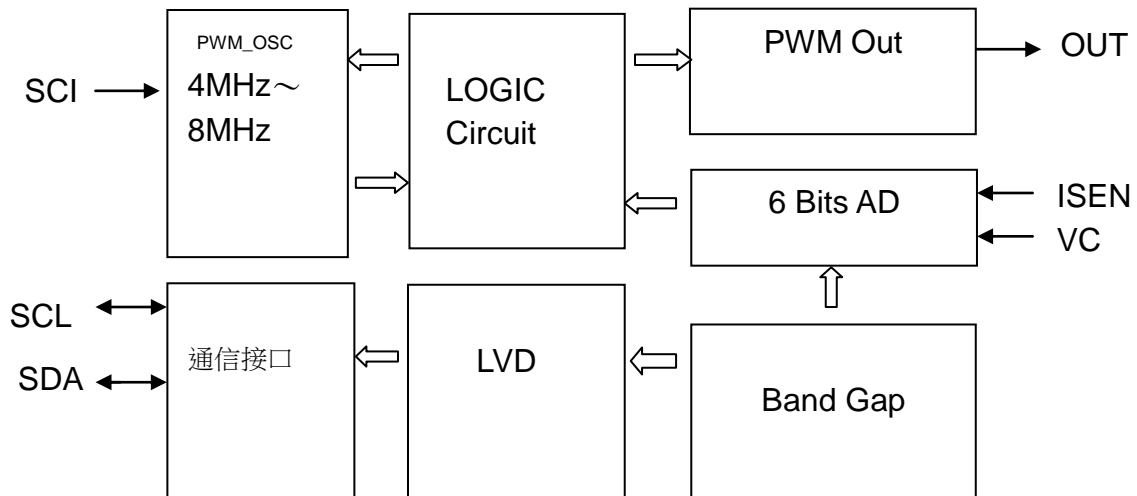

腳位定義

腳位順序	腳位名稱	I/O 類型	腳位定義
1	VDD	P	正電源供應
2	SCL	I/OD	通信接口 SCL I/O 腳
3	SCI	I	調整 PWM 頻率震盪輸入腳
4	SDA	I/OD	通信接口 SDA I/O 腳
5	OUT	O	共振片輸出控制腳
6	ISEN	I	電流偵測
7	VC	I	偏壓電容
8	VSS	P	負電源供應，接地

SDA /SCL pin have no Diode protective circuit

接腳類型

- I CMOS 單純輸入
- O CMOS 輸出
- I/O CMOS 輸入/輸出
- P 電源/接地
- I-PH CMOS 輸入內置上拉電阻
- I-PL CMOS 輸入內置下拉電阻
- I/OD 輸入/開漏輸出，無二極體保護電路

電氣特性

- 最大絕對額定值

參 數	符號	條 件	值	單位
工作溫度	T _{OP}	—	-20~+70	°C
儲存溫度	T _{STG}	—	-50~+125	°C
電源供應電壓	VDD	Ta=25°C	VSS-0.3~VSS+5.5	V
輸入電壓	V _{IN}	Ta=25°C	VSS-0.3~VDD+0.3	V
芯片抗靜電強度 HBM	ESD	—	5	KV

備註：VSS 代表系統接地

- DC / AC 特性：（測試條件為室溫 = 25 °C）

參 數	符號	測試條件	最小值	典型值	最大值	單位
工作電壓	VDD		2.4	5.0	5.5	V
低電壓偵測	LVD		3.04	3.2V	3.16	V
工作電流	I _{OFF}	VDD=5.0V System Off(待機)	-	-	2.0	uA
輸入埠	V _{IL}	輸入低電壓	0	-	0.2	VDD
輸入埠	V _{IH}	輸入高電壓	0.8	-	1.0	VDD
輸出埠灌電流 Sink Current	I _{OL}	VDD=5V, V _{OL} =1.0V	-	16	-	mA
輸出埠源電流 Source Current	I _{OH}	VDD=5V, V _{OH} =4.0V	-	14	-	mA

串列通訊波形

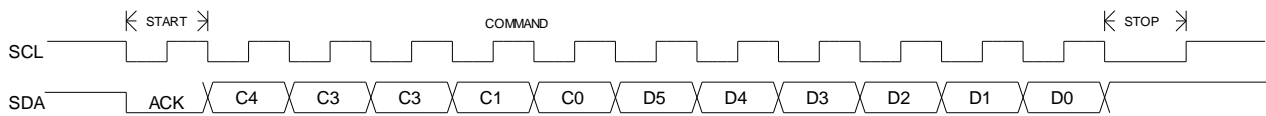

SCL: 下緣時 DATA 送出

SDA: 由 MSB 開始送

START: 串列通訊開始，TTP320-AO8 回應主控 Low 位準，確認連線正常

STOP: 串列通訊結束，確保 TTP320-AO8 的 data 釋放，回到高位準

COMMAND: COM 5bit (C4~C0); DATA 6 bit (D5~D0)

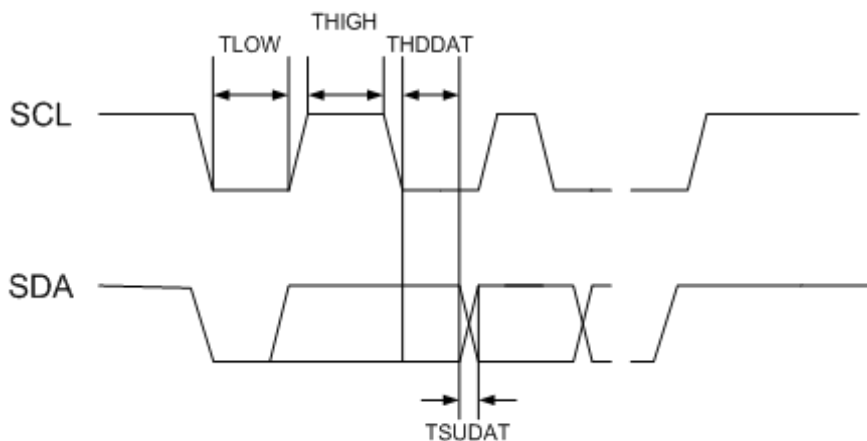

Switching Characteristics

Symbol	Description	Min	Max	Units
FCLK	CLK clock frequency	0	25	KHz
TLOW	Low period of the SCL clock.	20	2000	us
THIGH	High period of the SCL clock.	20	2000	us
THDDAT	Data hold time.	0	-	us
TSUDAT	Data set-up time.	250	-	ns

SCL 端超過 10ms (Min) 信號沒有變化，系統將會自行回到待機模式(TIME OUT 時間機制)

命令功能表:

MSB					LSB						R/W	Description
C4	C3	C2	C1	C0	D5	D4	D3	D2	D1	D0		
0	0	0	0	1	-	FDUTY(4:0)				W01	OUT small cycle	
					-	1	0	0	0		0	FDUTY define
0	0	1	0	0	SCAN_SD_ST(5:0)						W04	設定掃頻起點
					0	0	0	0	0	0		
0	0	1	0	1	SCAN_SD_END(5:0)						W05	設定掃頻結束點
					1	1	1	1	1	1		
0	0	1	1	0	SCAN_ON(2:0)			BCY(2:0)			W06	OUT big cycle
					0	0	0	0	0	0		read AD period
0	0	1	1	1	RADC_TP(1:0)		VC_DIS(1:0)		RADF(1:0)		W07	設定掃頻機制旗標
					0	1	0	0	0	1		
0	1	0	0	0	-	-	-	-	SD_CHG	RE_SCAN	W08	RE_SCAN
					-	-	-	-	1	<u>0</u>		
0	1	0	0	1	-	-	-	-	-	LVDEN	W09	LVD control
					-	-	-	-	-	0		
0	1	1	0	0	-	-	MCU_ON(3:0)				W0C	OUT output define
					-	-	0	0	0	0		power off
1	0	0	0	1	SCAN_T		N_NOWV	N_NOWS			R11	SCAN busy
1	0	0	1	0						LVDF	R12	LVD flag
1	0	0	1	1	MAX_VC(5:0)=N ; VC(max)=N*30mV						R13	Read 掃頻後之 VC 最高電位值
					n	n	n	N	n	n		
1	0	1	0	0	MAX_SD(5:0)=N ;						R14	Read 掃頻後之最佳掃頻值
					n	n	n	N	n	n		
1	0	1	1	0	NOW_VC(5:0)=N ; VC(now)=N*30mV						R16	Read 目前 VC 電壓值
					n	n	n	N	n	n		
1	0	1	1	1	NOW_SD(5:0)=N ;						R17	Read 目前掃頻設定值
					n	n	n	n	n	n		

$F(ato) = F(osc)/44$: $F(osc)=8M \sim 4M$ hz ; $F(ato)$: 霧化片工作頻率 : 180K~90K Hz

Note : SCAN_T =1 : SCAN Busy

SCAN_T =0 : SCAN non Busy

命令功能說明：
1. OUT Pin 輸出霧化片共振頻率的 DUTY 設定
W01/FDUTY(4:0) : OUT small cycle DUTY H/L ratio define

C4	C3	C2	C1	C0	D5	D4	D3	D2	D1	D0	
0	0	0	0	1	-	FDUTY(4:0)					W01
					-	1	0	0	0	0	

FDUTY(4:0)					DUTY H/L ratio		
(4)	(3)	(2)	(1)	(0)	DUTY_H	DUTY_L	Ratio
0	0	0	0	0	6	38	13.6%
0	0	0	0	1	7	37	15.9%
0	0	0	1	0	8	36	18.2%
0	0	0	1	1	9	35	20.5%
0	0	1	0	0	10	34	22.7%
0	0	1	0	1	11	33	25.0%
0	0	1	1	0	12	32	27.3%
0	0	1	1	1	13	31	29.5%
0	1	0	0	0	14	30	31.8%
0	1	0	0	1	15	29	34.1%
0	1	0	1	0	16	28	36.4%
0	1	0	1	1	17	27	38.6%
0	1	1	0	0	18	26	40.9%
0	1	1	0	1	19	25	43.2%
0	1	1	1	0	20	24	45.5%
0	1	1	1	1	21	23	47.7%
1	0	0	0	0	22	22	50.0%
1	0	0	0	1	23	21	52.3%
1	0	0	1	0	24	20	54.5%
1	0	0	1	1	25	19	56.8%
1	0	1	0	0	26	18	59.1%
1	0	1	0	1	27	17	61.4%
1	0	1	1	0	28	16	63.6%
1	0	1	1	1	29	15	65.9%
1	1	0	0	0	30	14	68.2%
1	1	0	0	1	31	13	70.5%
1	1	0	1	0	32	12	72.7%
1	1	0	1	1	33	11	75.0%
1	1	1	0	0	34	10	77.3%
1	1	1	0	1	35	9	79.5%
1	1	1	1	0	36	8	81.8%
1	1	1	1	1	37	7	84.1%

2. 設定 F(osc) 掃頻起始點: W04/SCAN_SD_ST(5:0)

C4	C3	C2	C1	C0	D5	D4	D3	D2	D1	D0	
0	0	1	0	0	VCE_ST(5:0)						W04
					0	0	0	0	0	0	

3. 設定 F(osc) 掃頻結束點: W05/SCAN_SD_ST(5:0)

C4	C3	C2	C1	C0	D5	D4	D3	D2	D1	D0	
0	0	1	0	1	VCE_END(5:0)						W05
					1	1	1	1	1	1	

If SCAN_SD_ST(5:0) = SCAN_SD_END(5:0), then fix SCAN_SD(5:0)

4. W06/BCY(2:0) : Define OUT big cycle VC charge time
W06/SCAN_ON(2:0) : define SCAN time OUT 功率(功率掃頻)

C4	C3	C2	C1	C0	D5	D4	D3	D2	D1	D0	
0	0	1	1	0	SCAN_ON(2:0)			BCY(2:0)			W06
					0	0	0	0	0	0	

5. Define OUT big cycle VC charge time : BCY(2:0)

BCY(2)	BCY(1)	BCY(0)	VC charge time
0	0	0	100.0%
0	0	1	87.5%
0	1	0	75.0%
0	1	1	62.5%
1	0	0	50.0%
1	0	1	37.5%
1	1	0	25.0%
1	1	1	12.5%

6. OUT 功率(功率掃頻) : SCAN_ON(2:0) : define SCAN time

SACN_ON(2)	SACN_ON(1)	SACN_ON(0)	OUT 功率(出水量)
0	0	0	100.0%
0	0	1	87.5%
0	1	0	75.0%
0	1	1	62.5%
1	0	0	50.0%
1	0	1	37.5%
1	1	0	25.0%
1	1	1	12.5%

Note : OUT 功率(出水量)說明 : Example: 50.0% (Duty)

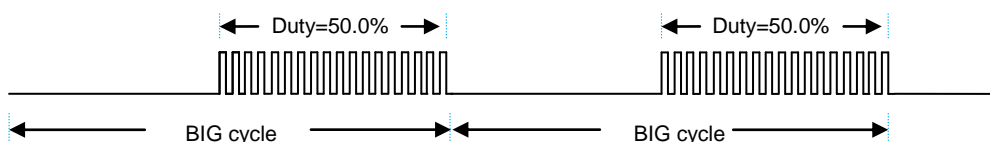

7. 設定掃頻機制旗標值: W07

C4	C3	C2	C1	C0	D5	D4	D3	D2	D1	D0	
0	0	1	1	1	RADC_TP(1:0)		VC_DIS(1:0)		RADF(1:0)		W07
					0	1	0	0	0	1	

8. Define read VC AD value period (BIG cycle) : RADC_TP(1:0)

RADC_TP(1)	RADC_TP(0)	Period
0	0	1024 OUT clock
0	1	2048 OUT clock
1	0	4096 OUT clock
1	1	8192 OUT clock

9. VC 電位 charge 之前先 Discharge voltage control : VC_DIS(1:0)

VC_DIS(1)	VC_DIS(0)	Discharge time
0	0	Disable discharge(0ms)
0	1	1ms
1	0	2ms
1	1	4ms

10. Define read AD value time , OUT and VC charge function : RADF(1:0)

RADF(1)	RADF(0)	OUT	VC
1	1	PWM	Charge voltage
1	0	PWM	No charge voltage
0	X	No PWM	No charge voltage

X: don't care

11. RE_SCAN : W08(0)

設定掃頻模式: W08(1)

C4	C3	C2	C1	C0	D5	D4	D3	D2	D1	D0	
0	1	0	0	0	-	-	-	-	SD_CHG	RE_SCAN	W08
					-	-	-	-	1	<u>0</u>	

RE_SCAN : 重新掃頻 ; F(osc) 掃頻完成前 RE_SCAN reset 為 0(無法設定)

set RE_SCAN=1 : 啟動重新掃頻

SD_CHG : 設定掃頻模式 :

SD_CHG=1 : 模式 1: 高低頻交錯掃頻

SD_CHG=0 : 模式 2: 由低頻往高頻順序掃頻

12. LVDEN: W09(0):

C4	C3	C2	C1	C0	D5	D4	D3	D2	D1	D0	
0	1	0	0	1	-	-	-	-	-	LVDEN	W09
					-	-	-	-	-	0	

LVDEN=0 : LVD Disable(default)

LVDEN=1 : LVD Enable

13. 掃頻規則模式說明
13-1 : 掃頻規則模式 1 (SD_CHG=1) 高低頻交錯掃描

SCAN_SD(5:0)						F(osc)
5	4	3	2	1	0	偏移率
0	0	0	0	0	0	-16.0%
0	0	0	0	0	1	15.5%
0	0	0	0	1	0	-15.5%
0	0	0	0	1	1	15.0%
0	0	0	1	0	0	-15.0%
0	0	0	1	0	1	14.5%
0	0	0	1	1	0	-14.5%
0	0	0	1	1	1	14.0%
0	0	1	0	0	0	-14.0%
0	0	1	0	0	1	13.5%
0	0	1	0	1	0	-13.5%
0	0	1	0	1	1	13.0%
0	0	1	1	0	0	-13.0%
0	0	1	1	0	1	12.5%
0	0	1	1	1	0	-12.5%
0	0	1	1	1	1	12.0%
0	1	0	0	0	0	-12.0%
0	1	0	0	0	1	11.5%
0	1	0	0	1	0	-11.5%
0	1	0	0	1	1	11.0%
0	1	0	1	0	0	-11.0%
0	1	0	1	0	1	10.5%
0	1	0	1	1	0	-10.5%
0	1	0	1	1	1	10.0%
0	1	1	0	0	0	-10.0%
0	1	1	0	0	1	9.5%
0	1	1	0	1	0	-9.5%
0	1	1	0	1	1	9.0%
0	1	1	1	0	0	-9.0%
0	1	1	1	0	1	8.5%
0	1	1	1	1	0	-8.5%
0	1	1	1	1	1	8.0%

SCAN_SD(5:0)						F(osc)
5	4	3	2	1	0	偏移率
1	0	0	0	0	0	-8.0%
1	0	0	0	0	1	7.5%
1	0	0	0	1	0	-7.5%
1	0	0	0	1	1	7.0%
1	0	0	1	0	0	-7.0%
1	0	0	1	0	1	6.5%
1	0	0	1	1	0	-6.5%
1	0	0	1	1	1	6.0%
1	0	1	0	0	0	-6.0%
1	0	1	0	0	1	5.5%
1	0	1	0	1	0	-5.5%
1	0	1	0	1	1	5.0%
1	0	1	1	0	0	-5.0%
1	0	1	1	0	1	4.5%
1	0	1	1	1	0	-4.5%
1	0	1	1	1	1	4.0%
1	1	0	0	0	0	-4.0%
1	1	0	0	0	1	3.5%
1	1	0	0	1	0	-3.5%
1	1	0	0	1	1	3.0%
1	1	0	1	0	0	-3.0%
1	1	0	1	0	1	2.5%
1	1	0	1	1	0	-2.5%
1	1	0	1	1	1	2.0%
1	1	1	0	0	0	-2.0%
1	1	1	0	0	1	1.5%
1	1	1	0	1	0	-1.5%
1	1	1	0	1	1	1.0%
1	1	1	1	0	0	-1.0%
1	1	1	1	0	1	0.5%
1	1	1	1	1	0	-0.5%
1	1	1	1	1	1	0.0%

13-2 掃頻規則模式 2 (SD_CHG=0) 由低頻往高頻順序掃頻

SCAN_SD(5:0)						F(osc)
5	4	3	2	1	0	偏移率
0	0	0	0	0	0	-16.0%
0	0	0	0	0	1	-15.5%
0	0	0	0	1	0	-15.0%
0	0	0	0	1	1	-14.5%
0	0	0	1	0	0	-14.0%
0	0	0	1	0	1	-13.5%
0	0	0	1	1	0	-13.0%
0	0	0	1	1	1	-12.5%
0	0	1	0	0	0	-12.0%
0	0	1	0	0	1	-11.5%
0	0	1	0	1	0	-11.0%
0	0	1	0	1	1	-10.5%
0	0	1	1	0	0	-10.0%
0	0	1	1	0	1	-9.5%
0	0	1	1	1	0	-9.0%
0	0	1	1	1	1	-8.5%
0	1	0	0	0	0	-8.0%
0	1	0	0	0	1	-7.5%
0	1	0	0	1	0	-7.0%
0	1	0	0	1	1	-6.5%
0	1	0	1	0	0	-6.0%
0	1	0	1	0	1	-5.5%
0	1	0	1	1	0	-5.0%
0	1	0	1	1	1	-4.5%
0	1	1	0	0	0	-4.0%
0	1	1	0	0	1	-3.5%
0	1	1	0	1	0	-3.0%
0	1	1	0	1	1	-2.5%
0	1	1	1	0	0	-2.0%
0	1	1	1	0	1	-1.5%
0	1	1	1	1	0	-1.0%
0	1	1	1	1	1	-0.5%

SCAN_SD(5:0)						F(osc)
5	4	3	2	1	0	偏移率
1	0	0	0	0	0	0.0%
1	0	0	0	0	1	0.5%
1	0	0	0	1	0	1.0%
1	0	0	0	1	1	1.5%
1	0	0	1	0	0	2.0%
1	0	0	1	0	1	2.5%
1	0	0	1	1	0	3.0%
1	0	0	1	1	1	3.5%
1	0	1	0	0	0	4.0%
1	0	1	0	0	1	4.5%
1	0	1	0	1	0	5.0%
1	0	1	0	1	1	5.5%
1	0	1	1	0	0	6.0%
1	0	1	1	0	1	6.5%
1	0	1	1	1	0	7.0%
1	0	1	1	1	1	7.5%
1	1	0	0	0	0	8.0%
1	1	0	0	0	1	8.5%
1	1	0	0	1	0	9.0%
1	1	0	0	1	1	9.5%
1	1	0	1	0	0	10.0%
1	1	0	1	0	1	10.5%
1	1	0	1	1	0	11.0%
1	1	0	1	1	1	11.5%
1	1	1	0	0	0	12.0%
1	1	1	0	0	1	12.5%
1	1	1	0	1	0	13.0%
1	1	1	0	1	1	13.5%
1	1	1	1	0	0	14.0%
1	1	1	1	0	1	14.5%
1	1	1	1	1	0	15.0%
1	1	1	1	1	1	15.5%

14. 開機模式: W0C/MCU_ON(3:0)

C4	C3	C2	C1	C0	D5	D4	D3	D2	D1	D0	Description	
0	1	1	0	0	-	-	0	0	0	0	System off	
					-	-	0	0	0	1		
					-	-	0	0	1	0		
					-	-	0	0	1	1		
					-	-	0	1	0	0		
					-	-	0	1	0	1		
					-	-	0	1	1	0		
				-	-	0	1	1	1	0	ON_L0	
				-	-	1	0	0	0	100.0%	ON_L8	
				-	-	1	0	0	1	87.5%	ON_L7	
				-	-	1	0	1	0	75.0%	ON_L6	
				-	-	1	0	1	1	62.5%	ON_L5	
				-	-	1	1	0	0	50.0%	ON_L4	
				-	-	1	1	0	1	37.5%	ON_L3	
-	-	1	1	1	0	25.0%	ON_L2					
-	-	1	1	1	1	12.5%	ON_L1					

Note: OUT 功率(出水量) 共分 9 個百分比 ON_L0 ~ON_L8

15. Read 回傳值 :

C4	C3	C2	C1	C0	D5	D4	D3	D2	D1	D0	R/W	Description	
1	0	0	0	1	SCAN_T		N_NOWV		N_NOWS		R11	SCAN busy	
1	0	0	1	0							LVDF	R12	LVD flag
1	0	0	1	1	MAX_VC(5:0)=N ; VC(max)=N*30mV						R13	Read 掃頻後之 VC 最高電位值	
					n	n	n	n	n	n			
1	0	1	0	0	MAX_SD(5:0)=N ;						R14	Read 掃頻後之最佳掃頻值	
					n	n	n	n	n	n			
1	0	1	1	0	NOW_VC(5:0)=N ; VC(now)=N*30mV						R16	Read 目前 VC 電壓值	
					n	n	n	n	n	n			
1	0	1	1	1	NOW_SD(5:0)=N ;						R17	Read 目前掃頻設定值	
					n	n	n	n	n	n			

R11_D5 : SCAN_T =1 busy(掃頻中); SCAN_T =0 (掃頻已完成)

R11_D3 : N_NOWV : NOW_VC(5:0) index
N_NOWV =0 (new value); N_NOWV ==1 (old value)

R11_D2 : N_NOWS : NOW_SD(5:0) index
N_NOWS =0 (new value); N_NOWS ==1 (old value)

R13_D(5:0) : MAX_VC(5:0) : 掃頻結束後最高電壓值 VC(max)

R14_D(5:0) : MAX_SD(5:0) : 最高電壓值 VC(max), 相對工作頻率 SD(max)

R16_D(5:0) : NOW_VC(5:0) : 最近一筆 VC(now) 電壓值

R17_D(5:0) : NOW_SD(5:0) : 最近一筆 VC(now) 相對工作頻率 SD(now)

R12_D0 : 讀取 LVDF 後, 隨即清除 LVDF, 當電壓低於偵測電壓 3.2V, LVDF 將被設定為 1, LVDF 設定為 1 後不會因電壓高於 3.2V 而清除, 需經由讀取 LVDF 狀態(R12)設定後才會清除。

TTP320-AO8 串列通訊：

設定：OUT 頻率 DUTY H/L 比、OUT 掃頻起始點和結束點、設定掃頻機制、OUT 輸出設定(ON/OFF，功率調整)。

讀取：SCAN busy 旗標、掃頻後之最高電位值、掃頻後之最佳掃頻值、最近一筆 VC 電壓值、最近一筆 OUT 相對工作頻率值

共振頻率匹配：

IC 與霧化片中心共振頻率的匹配可透過 SCI 腳位外接電阻值(R1)調整, 有下列兩種方式

1.調整霧化片的 PWM 頻率時, 先將 SCAN_SD_ST 和 SCAN_SD_END 設為 20H, 中心頻率 0%的位置, 再調整 SCI 外接電阻, 以得到最佳的諧振頻率, 量產時可有+15%/- 15%的調整範圍, 可於每次開機時, 自動調整到最佳頻率, 降低霧化片老化及誤差的影響。

2.上電前時先將 SCL 腳位接地, 上電後 0.3 秒 OUT 腳位便輸出 IC 的 PWM 中心頻率。

如下圖所示。

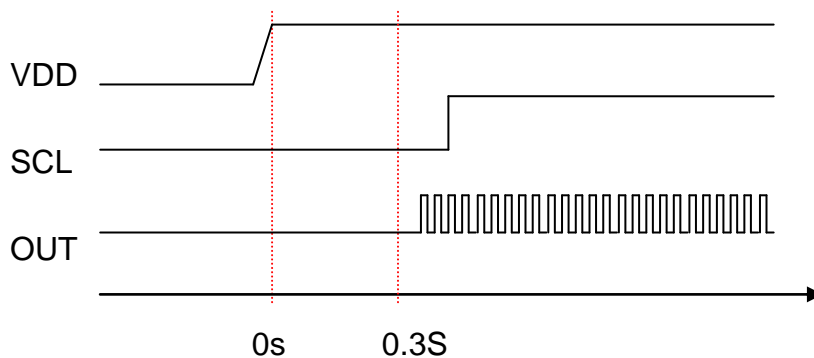

1. VDD=5V, SCI 阻值(R1)和 OUT 輸出 PWM 中心頻率如下表：

SCI 阻值 (R1)	OUT PWM 中心頻率
30KΩ	179 KHz
33KΩ	163 KHz
36KΩ	151 KHz
39KΩ	140 KHz
43KΩ	125 KHz
47KΩ	118 KHz
51KΩ	109 KHz
56KΩ	101 KHz
62KΩ	92 KHz

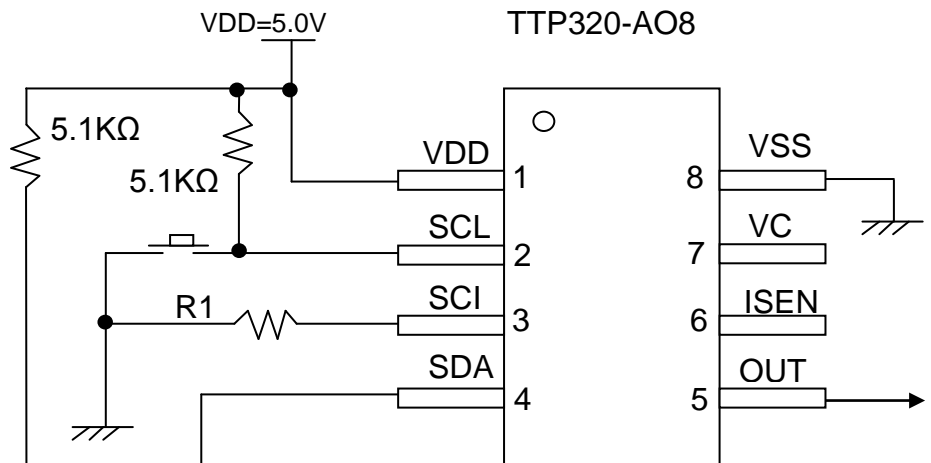

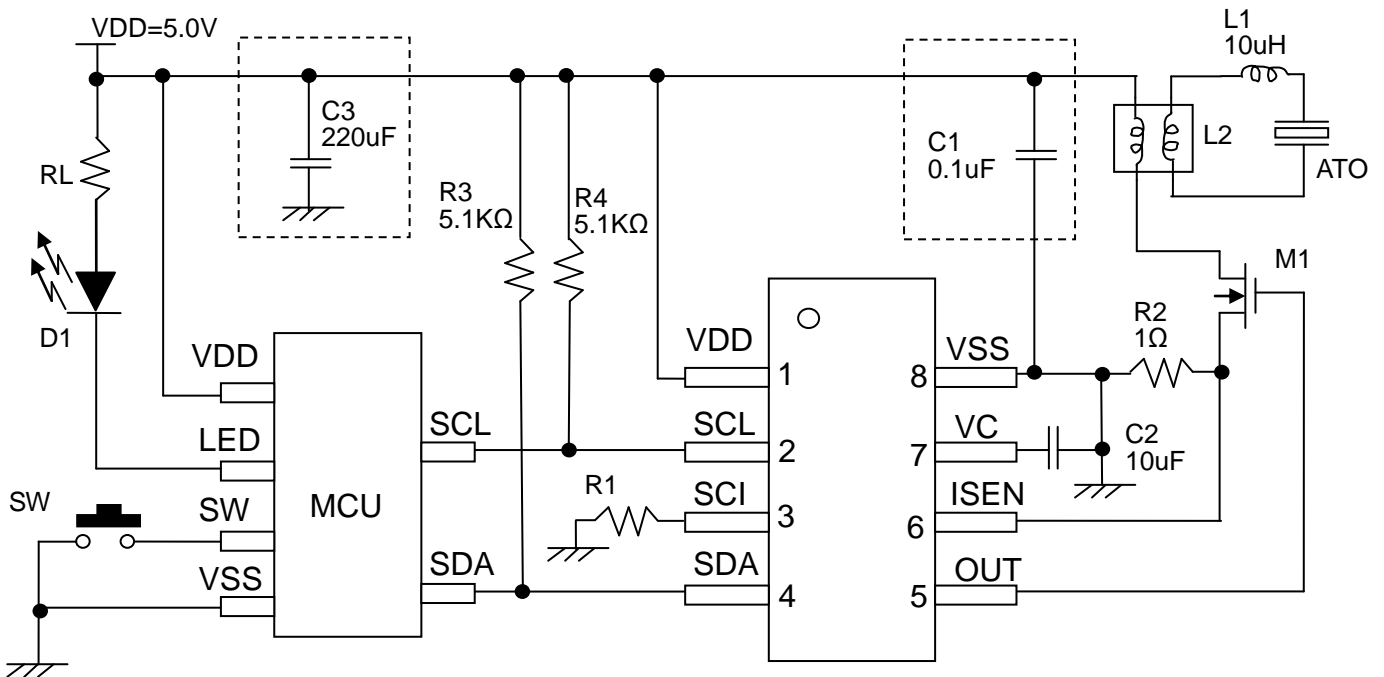

- 註：
1. 在 PCB 上，要注意 M1 散熱。
 2. C2 須盡量靠近 IC。
 3. L2 線圈比請依霧化片驅動電壓選擇
 4. M1 NMOS 電晶體驅動能力依霧化片功率選擇

BOM表

器件標示	器件名稱	器件參數
C1	滌綸電容	0.1uF (*1)
C2	電解電容	10uF/16V
C3	電解電容	220uF/16V(*1)
R1	碳膜電阻	阻值請參考 Page 12
R2	碳膜電阻	1Ω
R3	碳膜電阻	5.1KΩ
R4	碳膜電阻	5.1KΩ
RL	碳膜電阻	依 D1 規格選擇
D1	LED	發光二極管
L1	色環電感	10uH
L2	高頻變壓器	線繞比 (依霧化片規格)
M1	場效應管 NMOS 管	依霧化片規格
SW	開關	按鍵開關
ATO	微孔型超音波霧化片	共振頻率 90KHz~180KHz(*2)

說明: (*1)電源濾波元件視情況安裝

(*2)電路中請選一個中心頻率的霧化片

TTP320-AO8 System ON / OFF 軟件程序說明

Examp 1: 全頻(中心頻±15%)掃描流程(所需時間約 2.0 秒)

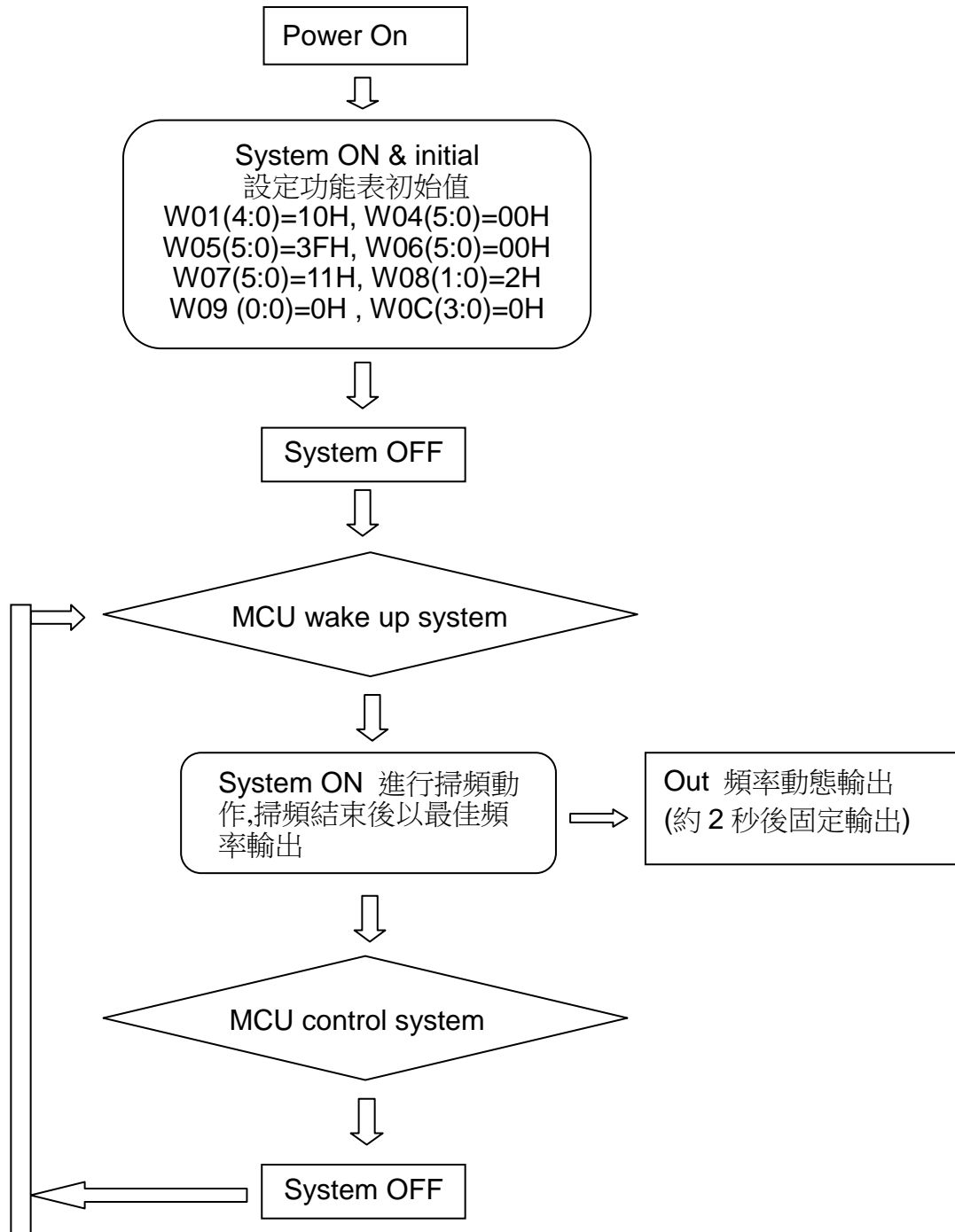

Examp 2: 單一頻掃描流程(所需時間約 50 毫秒)

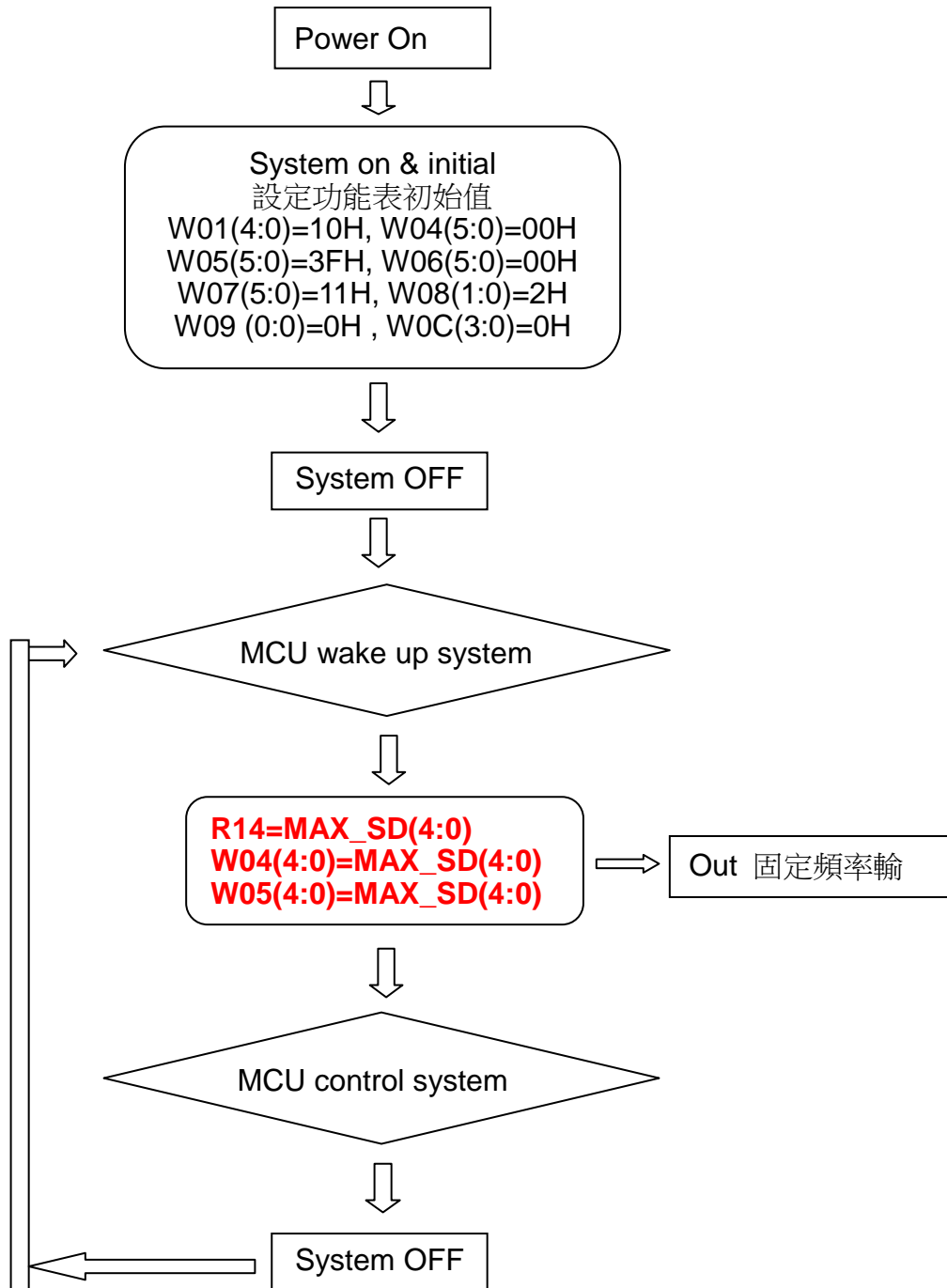

封裝外觀尺寸

SOP 8

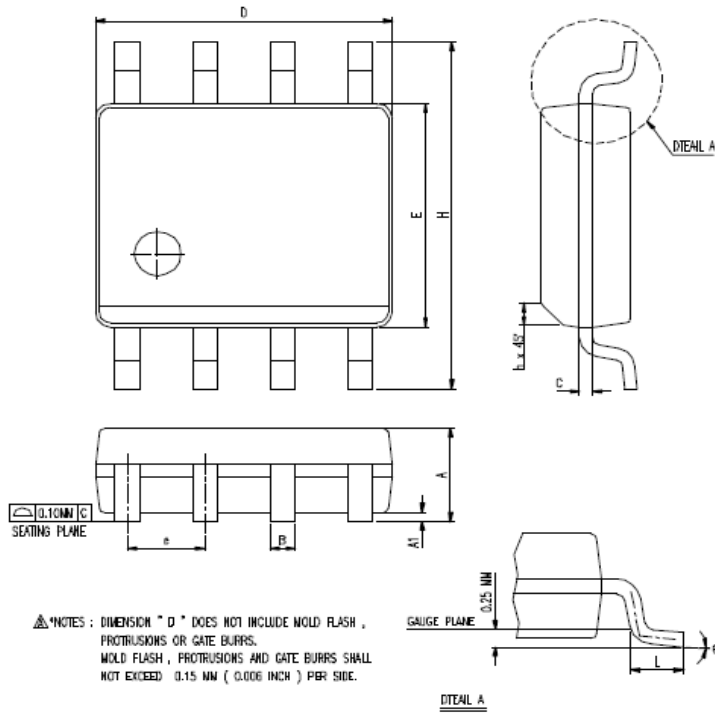

SYMBOL	DIMENSION IN MM		DIMENSION IN INCH	
	MIN	MAX	MIN	MAX
A	1.35	1.75	0.0532	0.0688
A1	0.10	0.25	0.0040	0.0098
B	0.33	0.51	0.013	0.020
C	0.19	0.25	0.0075	0.0098
e	1.27 BSC		0.050 BSC	
D	4.80	5.00	0.1890	0.1968
H	5.80	6.20	0.2284	0.2440
E	3.80	4.00	0.1497	0.1574
L	0.40	1.27	0.016	0.050
h	0.25	0.50	0.0099	0.0196
θ	0°	8°	0°	8°

訂 購 資 訊

TTP320

封裝型號	晶片型號	晶圓型號
TTP320-AO8	---	---

REVISION HISTORY:

- 2017/12/27: Initial version V1.0.
- 2018/10/24: version V1.1 修改 LVD 電壓, 修改功能說明.
- 2018/11/16: modify 封裝外觀尺寸 version V1.2