

#### 产品特性 Features

输出电压 <b>Output Voltage</b>	稳压管 Regulators
<b>5V</b>	<b>FHP7805A</b>
<b>8V</b>	<b>FHP7808A</b>
<b>9V</b>	<b>FHP7809A</b>
<b>12V</b>	<b>FHP7812A</b>
<b>15V</b>	<b>FHP7815A</b>
<b>24V</b>	<b>FHP7824A</b>
最大输出电流 <b>Max Output Current</b>	<b>1.5A</b>
过载保护 <b>Internal thermal overload prection</b>	
短路电流限制 <b>Internal short-current limiting</b>	
输出端最大安全工作区域 <b>Output transistor safe-area compensation</b>	
输出电压精度在 4% 以内 <b>Output voltage offered in 4% tolerance</b>	

#### 封装形式 Package



1:Input 2:GND 3:Output

#### 功能图 Functional diagram

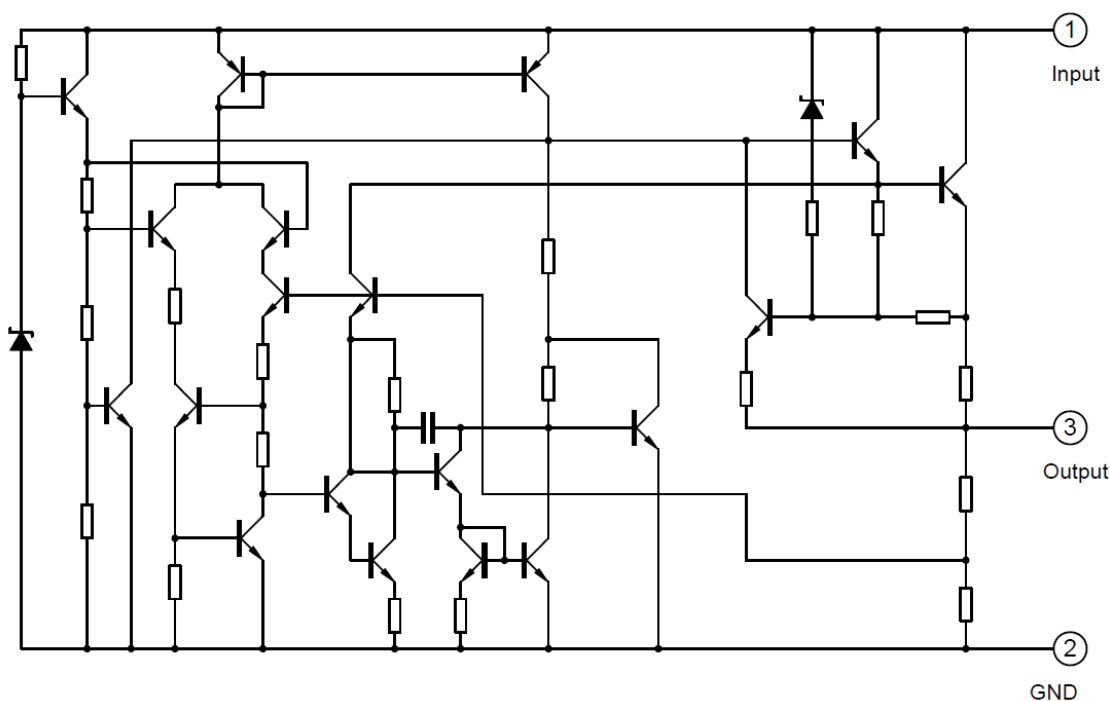

Fig.1

#### 绝对最大额定值 Absolute Maximum Rating (Ta = 25°C unless otherwise noted)

Parameter 项目	Symbol 符号	Limit 极限值		Unit
输入电压 Input Voltage	V <sub>in</sub>	for V <sub>o</sub> =5V to V <sub>o</sub> =18V	35	V
		for V <sub>o</sub> =24V	40	
功率损耗 Power Dissipation	P <sub>D</sub>	Internal Limited		W
存储温度 Storage Temperature Range	T <sub>STG</sub>	-65~+150		°C
工作温度 Operating Temperature	T <sub>OPR</sub>	-25~+125		°C
结-壳的热阻 Thermal Resistance -Junction to Case	R <sub>θJC</sub>	5		°C/W
结-环境的热阻 Thermal Resistance -Junction to Ambient	R <sub>θJA</sub>	50		°C/W

## FHP7805A 电参数特性 Electrical Characteristics

( $V_{in}=10V$ ,  $I_{out}=500mA$ ,  $0^{\circ}C \leq T_j \leq 125^{\circ}C$ ,  $C_{in}=0.33\mu F$ ,  $C_{out}=0.1\mu F$ ; unless otherwise specified.)

Parameter	Symbol	Test Condition	Min	Typ	Max	Unit
输出电压 Output voltage	$V_{out}$	$T_j=25^{\circ}C$ $7.5V \leq V_{in} \leq 20V$ , $5mA \leq I_{out} \leq 1A$ , $PD \leq 15W$	4.80 4.75	5 5	5.20 5.25	V
线性调节 Line Regulation	REGline	$T_j=25^{\circ}C$				mV
		$7.5V \leq V_{in} \leq 25V$ $8V \leq V_{in} \leq 12V$	-- --	4 1.6	100 50	
负载调节 Load Regulation	REGload	$T_j=25^{\circ}C$				mV
		$5mA \leq I_{out} \leq 1.5A$ $250mA \leq I_{out} \leq 750mA$	-- --	9 4	100 50	
静态电流 Quiescent Current	$I_q$	$I_{out}=0$ , $T_j=25^{\circ}C$	--	5.0	8	mA
静态电流变化 Quiescent Current Change	$\Delta I_q$	$8.0V \leq V_{in} \leq 25V$ $5mA \leq I_{out} \leq 1A$	-- --	-- --	0.8 0.5	
输出电压纹波 Output Noise Voltage	$V_n$	$10Hz \leq f \leq 100KHz$ , $T_j=25^{\circ}C$	--	42	--	$\mu V$
浪涌衰减 Ripple Rejection Ratio	RR	$f=120Hz$ , $8V \leq V_{in} \leq 18V$	62	73	--	dB
衰减电压 Voltage Drop	$V_{drop}$	$I_{out}=1A$ , $T_j=25^{\circ}C$	--	2	--	V
短路电流 Output Short Circuit Current	$I_{os}$	$T_j=25^{\circ}C$	--	230	--	mA
峰值电流 Peak Output Current	$I_{o\ peak}$	$T_j=25^{\circ}C$	--	2.2	--	A
输出电压特性 Temperature Coefficient of Output Voltage	$\Delta V_{out} / \Delta T_j$	$I_{out}=5mA$ , $0^{\circ}C \leq T_j \leq 125^{\circ}C$	--	0.8	--	$mV/^{\circ}C$
输出端电阻 Output resistance	$R_o$	$f=1KHz$	--	15	--	$m\Omega$

## FHP7808A 电参数特性 Electrical Characteristics

( $V_{in}=14V$ ,  $I_{out}=500mA$ ,  $0^{\circ}C \leq T_j \leq 125^{\circ}C$ ,  $C_{in}=0.33\mu F$ ,  $C_{out}=0.1\mu F$ ; unless otherwise specified.)

Parameter	Symbol	Test Condition	Min	Typ	Max	Unit
输出电压 Output voltage	$V_{out}$	$T_j=25^{\circ}C$ $11V \leq V_{in} \leq 23V$ , $5mA \leq I_{out} \leq 1A$ , $PD \leq 15W$	7.7 7.6	8.0 8.0	8.3 8.4	V
线性调节 Line Regulation	REGline	$T_j=25^{\circ}C$				mV
		$10.5V \leq V_{in} \leq 25V$ $11V \leq V_{in} \leq 17V$	-- --	5.0 2.0	160 80	
负载调节 Load Regulation	REGload	$T_j=25^{\circ}C$				mV
		$5mA \leq I_{out} \leq 1.5A$ $250mA \leq I_{out} \leq 750mA$	-- --	10 5.0	160 80	
静态电流 Quiescent Current	$I_q$	$I_{out}=0$ , $T_j=25^{\circ}C$	--	5.0	8	mA
静态电流变化 Quiescent Current Change	$\Delta I_q$	$11V \leq V_{in} \leq 25V$ $5mA \leq I_{out} \leq 1A$	-- --	-- --	0.8 0.5	
输出电压纹波 Output Noise Voltage	$V_n$	$10Hz \leq f \leq 100KHz$ , $T_j=25^{\circ}C$	--	52	--	$\mu V$
浪涌衰减 Ripple Rejection Ratio	RR	$f=120Hz$ , $11.5V \leq V_{in} \leq 21.5V$	56	73	--	dB
衰减电压 Voltage Drop	$V_{drop}$	$I_{out}=1A$ , $T_j=25^{\circ}C$	--	2	--	V
短路电流 Output Short Circuit Current	$I_{os}$	$T_j=25^{\circ}C$	--	230	--	mA
峰值电流 Peak Output Current	$I_{o\ peak}$	$T_j=25^{\circ}C$	--	2.2	--	A
输出电压特性 Temperature Coefficient of Output Voltage	$\Delta V_{out} / \Delta T_j$	$I_{out}=5mA$ , $0^{\circ}C \leq T_j \leq 125^{\circ}C$	--	0.8	--	$mV/^{\circ}C$
输出端电阻 Output resistance	$R_o$	$f=1KHz$	--	17	--	$m\Omega$

## FHP7809A 电参数特性 Electrical Characteristics

( $V_{in}=15V$ ,  $I_{out}=500mA$ ,  $0^{\circ}C \leq T_j \leq 125^{\circ}C$ ,  $C_{in}=0.33\mu F$ ,  $C_{out}=0.1\mu F$ ; unless otherwise specified.)

Parameter	Symbol	Test Condition	Min	Typ	Max	Unit	
输出电压 Output voltage	Vout	$T_j=25^{\circ}C$	8.65	9.0	9.35	V	
		$11.5V \leq V_{in} \leq 24V$ , $5mA \leq I_{out} \leq 1A$ , $PD \leq 15W$	8.6	9.0	9.4		
线性调节 Line Regulation	REGline	$T_j=25^{\circ}C$	$11.5V \leq V_{in} \leq 25V$	--	6.0	180	mV
			$12V \leq V_{in} \leq 25V$	--	2.0	90	
负载调节 Load Regulation	REGload	$T_j=25^{\circ}C$	$5mA \leq I_{out} \leq 1.5A$	--	12	180	
			$250mA \leq I_{out} \leq 750mA$	--	5.0	90	
静态电流 Quiescent Current	Iq	$I_{out}=0$ , $T_j=25^{\circ}C$	--	5.0	8	mA	
静态电流变化 Quiescent Current Change	$\Delta Iq$	$12V \leq V_{in} \leq 26V$	--	--	0.8		
		$5mA \leq I_{out} \leq 1A$	--	--	0.5		
输出电压纹波 Output Noise Voltage	Vn	$10Hz \leq f \leq 100KHz$ , $T_j=25^{\circ}C$	--	58	--	$\mu V$	
浪涌衰减 Ripple Rejection Ratio	RR	$f=120Hz$ , $11.5V \leq V_{in} \leq 21.5V$	56	73	--	dB	
衰减电压 Voltage Drop	Vdrop	$I_{out}=1A$ , $T_j=25^{\circ}C$	--	2	--	V	
短路电流 Output Short Circuit Current	Ios	$T_j=25^{\circ}C$	--	230	--	mA	
峰值电流 Peak Output Current	I <sub>o peak</sub>	$T_j=25^{\circ}C$	--	2.2	--	A	
输出电压特性 Temperature Coefficient of Output Voltage	$\Delta V_{out} / \Delta T_j$	$I_{out}=5mA$ , $0^{\circ}C \leq T_j \leq 125^{\circ}C$	--	1.0	--	mV/ $^{\circ}C$	
输出端电阻 Output resistance	Ro	$f=1KHz$	--	15	--	m $\Omega$	

## FHP7812A 电参数特性 Electrical Characteristics

( $V_{in}=19V$ ,  $I_{out}=500mA$ ,  $0^{\circ}C \leq T_j \leq 125^{\circ}C$ ,  $C_{in}=0.33\mu F$ ,  $C_{out}=0.1\mu F$ ; unless otherwise specified.)

Parameter	Symbol	Test Condition	Min	Typ	Max	Unit	
输出电压 Output voltage	Vout	$T_j=25^{\circ}C$	11.5	12.0	12.5	V	
		$14.5V \leq V_{in} \leq 27V$ , $5mA \leq I_{out} \leq 1A$ , $PD \leq 15W$	11.4	12.0	12.6		
线性调节 Line Regulation	REGline	$T_j=25^{\circ}C$	$14.5V \leq V_{in} \leq 30V$	--	10	240	mV
			$16V \leq V_{in} \leq 22V$	--	3	120	
负载调节 Load Regulation	REGload	$T_j=25^{\circ}C$	$5mA \leq I_{out} \leq 1.5A$	--	12	240	
			$250mA \leq I_{out} \leq 750mA$	--	5.0	120	
静态电流 Quiescent Current	Iq	$I_{out}=0$ , $T_j=25^{\circ}C$	--	5.1	8	mA	
静态电流变化 Quiescent Current Change	$\Delta Iq$	$15V \leq V_{in} \leq 30V$	--	--	0.8		
		$5mA \leq I_{out} \leq 1A$	--	--	0.5		
输出电压纹波 Output Noise Voltage	Vn	$10Hz \leq f \leq 100KHz$ , $T_j=25^{\circ}C$	--	76	--	$\mu V$	
浪涌衰减 Ripple Rejection Ratio	RR	$f=120Hz$ , $15V \leq V_{in} \leq 25V$	55	71	--	dB	
衰减电压 Voltage Drop	Vdrop	$I_{out}=1A$ , $T_j=25^{\circ}C$	--	2	--	V	
短路电流 Output Short Circuit Current	Ios	$T_j=25^{\circ}C$	--	230	--	mA	
峰值电流 Peak Output Current	I <sub>o peak</sub>	$T_j=25^{\circ}C$	--	2.2	--	A	
输出电压特性 Temperature Coefficient of Output Voltage	$\Delta V_{out} / \Delta T_j$	$I_{out}=5mA$ , $0^{\circ}C \leq T_j \leq 125^{\circ}C$	--	1.0	--	mV/ $^{\circ}C$	
输出端电阻 Output resistance	Ro	$f=1KHz$	--	18	--	m $\Omega$	

## FHP7815A 电参数特性 Electrical Characteristics

( $V_{in}=23V$ ,  $I_{out}=500mA$ ,  $0^{\circ}C \leq T_j \leq 125^{\circ}C$ ,  $C_{in}=0.33\mu F$ ,  $C_{out}=0.1\mu F$ ; unless otherwise specified.)

Parameter	Symbol	Test Condition	Min	Typ	Max	Unit	
输出电压 Output voltage	Vout	$T_j=25^{\circ}C$	14.4	15.0	15.6	V	
		$17.5V \leq V_{in} \leq 30V$ , $5mA \leq I_{out} \leq 1A$ , $PD \leq 15W$	14.25	15.0	15.75		
线性调节 Line Regulation	REGline	$T_j=25^{\circ}C$	$17.5V \leq V_{in} \leq 30V$	--	11	300	mV
			$20V \leq V_{in} \leq 26V$	--	3	150	
负载调节 Load Regulation	REGload	$T_j=25^{\circ}C$	$5mA \leq I_{out} \leq 1.5A$	--	12	300	mV
			$250mA \leq I_{out} \leq 750mA$	--	5.0	150	
静态电流 Quiescent Current	Iq	$I_{out}=0$ , $T_j=25^{\circ}C$	--	5.2	8	mA	
静态电流变化 Quiescent Current Change	$\Delta Iq$	$18V \leq V_{in} \leq 30.5V$	--	--	0.8		
		$5mA \leq I_{out} \leq 1A$	--	--	0.5		
输出电压纹波 Output Noise Voltage	Vn	$10Hz \leq f \leq 100KHz$ , $T_j=25^{\circ}C$	--	90	--	$\mu V$	
浪涌衰减 Ripple Rejection Ratio	RR	$f=120Hz$ , $18.5V \leq V_{in} \leq 28.5V$	54	70	--	dB	
衰减电压 Voltage Drop	Vdrop	$I_{out}=1A$ , $T_j=25^{\circ}C$	--	2	--	V	
短路电流 Output Short Circuit Current	Ios	$T_j=25^{\circ}C$	--	230	--	mA	
峰值电流 Peak Output Current	I <sub>o peak</sub>	$T_j=25^{\circ}C$	--	2.2	--	A	
输出电压特性 Temperature Coefficient of Output Voltage	$\Delta V_{out} / \Delta T_j$	$I_{out}=5mA$ , $0^{\circ}C \leq T_j \leq 125^{\circ}C$	--	1.0	--	$mV/^{\circ}C$	
输出端电阻 Output resistance	Ro	$f=1KHz$	--	19	--	$m\Omega$	

## FHP7824A 电参数特性 Electrical Characteristics

( $V_{in}=33V$ ,  $I_{out}=500mA$ ,  $0^{\circ}C \leq T_j \leq 125^{\circ}C$ ,  $C_{in}=0.33\mu F$ ,  $C_{out}=0.1\mu F$ ; unless otherwise specified.)

Parameter	Symbol	Test Condition	Min	Typ	Max	Unit	
输出电压 Output voltage	Vout	$T_j=25^{\circ}C$	23	24	25	V	
		$27V \leq V_{in} \leq 38V$ , $5mA \leq I_{out} \leq 1A$ , $PD \leq 15W$	22.8	24	25.2		
线性调节 Line Regulation	REGline	$T_j=25^{\circ}C$	$27V \leq V_{in} \leq 38V$	--	17	480	mV
			$30V \leq V_{in} \leq 36V$	--	6	240	
负载调节 Load Regulation	REGload	$T_j=25^{\circ}C$	$5mA \leq I_{out} \leq 1.5A$	--	15	480	mV
			$250mA \leq I_{out} \leq 750mA$	--	5.0	240	
静态电流 Quiescent Current	Iq	$I_{out}=0$ , $T_j=25^{\circ}C$	--	5.2	8	mA	
静态电流变化 Quiescent Current Change	$\Delta Iq$	$27V \leq V_{in} \leq 38V$	--	--	1.0		
		$5mA \leq I_{out} \leq 1A$	--	--	0.5		
输出电压纹波 Output Noise Voltage	Vn	$10Hz \leq f \leq 100KHz$ , $T_j=25^{\circ}C$	--	160	--	$\mu V$	
浪涌衰减 Ripple Rejection Ratio	RR	$f=120Hz$ , $28V \leq V_{in} \leq 38V$	50	67	--	dB	
衰减电压 Voltage Drop	Vdrop	$I_{out}=1A$ , $T_j=25^{\circ}C$	--	2	--	V	
短路电流 Output Short Circuit Current	Ios	$T_j=25^{\circ}C$	--	230	--	mA	
峰值电流 Peak Output Current	I <sub>o peak</sub>	$T_j=25^{\circ}C$	--	2.2	--	A	
输出电压特性 Temperature Coefficient of Output Voltage	$\Delta V_{out} / \Delta T_j$	$I_{out}=5mA$ , $0^{\circ}C \leq T_j \leq 125^{\circ}C$	--	1.0	--	$mV/^{\circ}C$	
输出端电阻 Output resistance	Ro	$f=1KHz$	--	28	--	$m\Omega$	

# 测试电路 Test Circuits

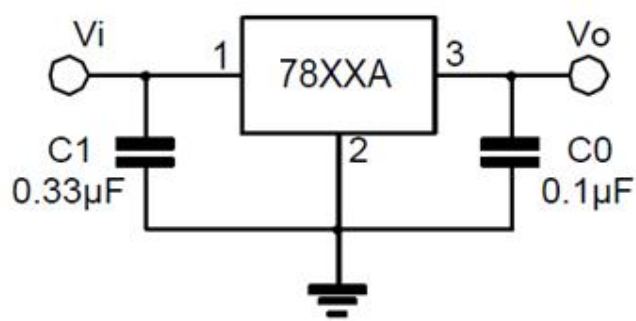

FIG.2 DC PARAMETERS

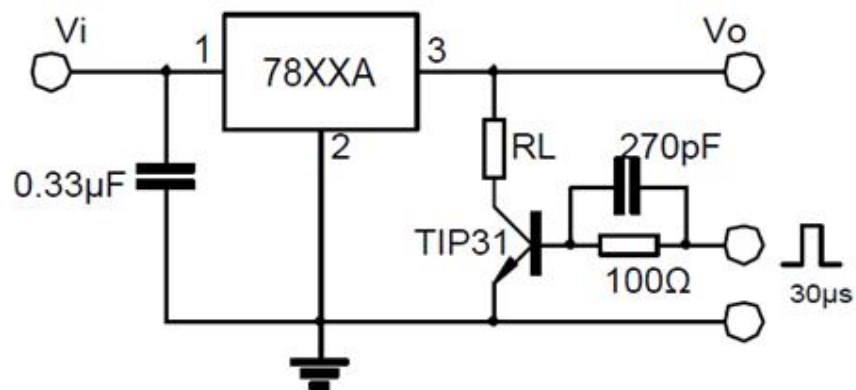

FIG.3 LOAD REGULATION

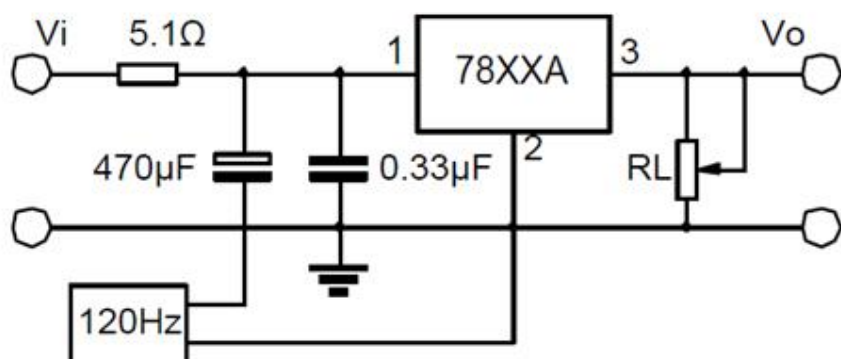

FIG.4 RIPPLE REJECTION

# 典型应用电路 Typical application circuit

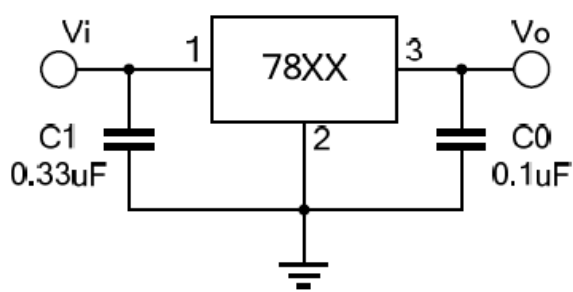

Fig.5 Fixed output regulator

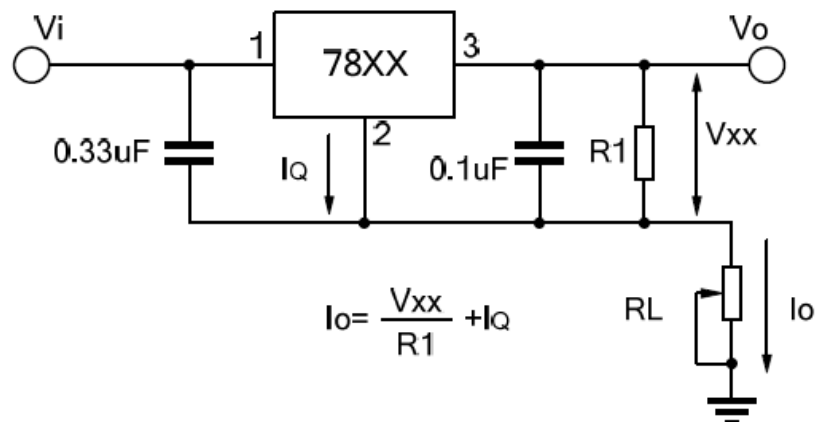

Fig.6 Constant current regulator

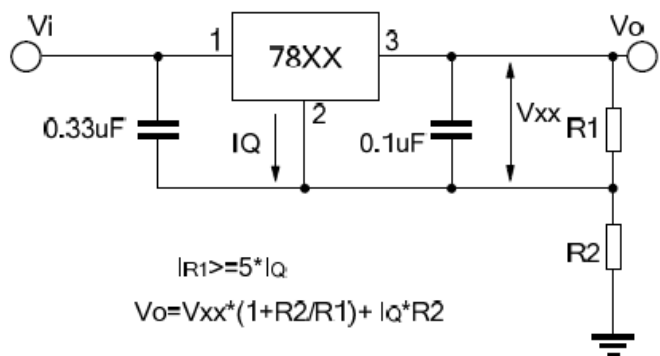

Fig.7 Circuit for increasing Regulator output voltage

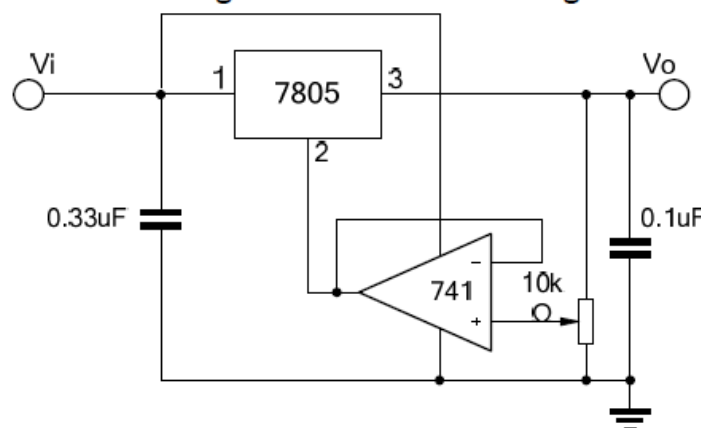
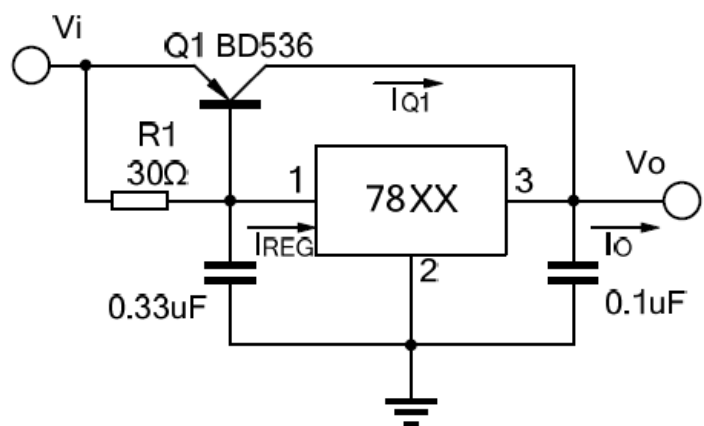

Fig.8 Adjustable output



$$I_o = I_{REG} \cdot (I_{REG} - V_{BEQ1} / R_1)$$

$$R_1 = V_{BEQ1} / (I_{REG} - I_{Q1} \cdot Q_1)$$

Fig.9.1 High current with voltage regulator

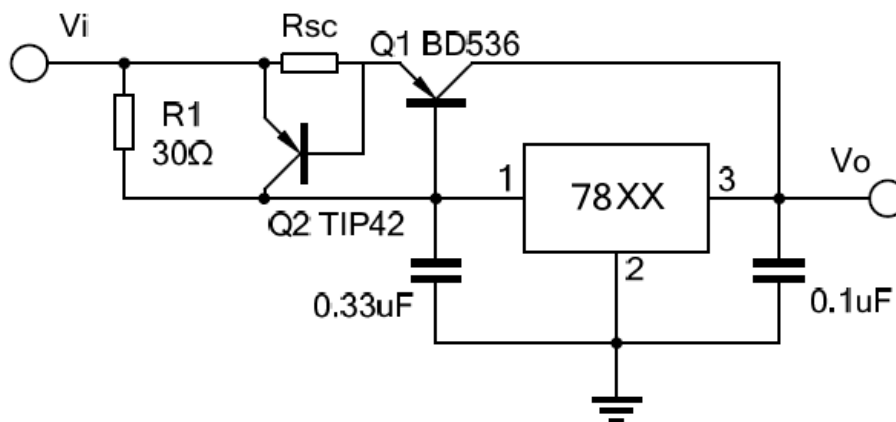

$$R_{sc} = V_{BEQ2} / I_{sc}$$

Fig.9.2 High output current short circuit protection

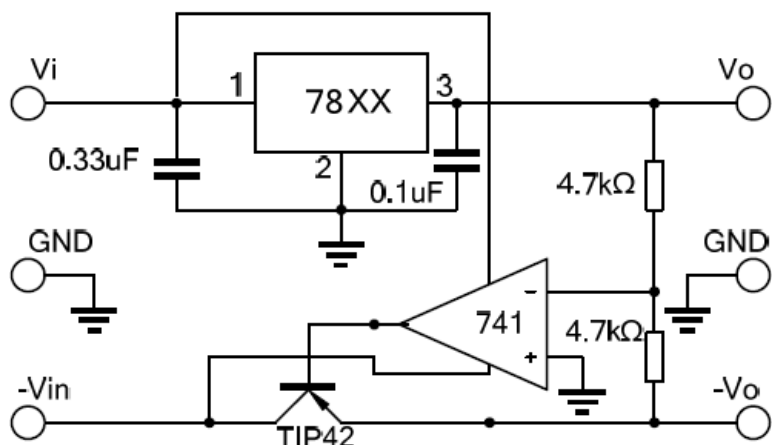

Fig.10 Tracking voltage regulator

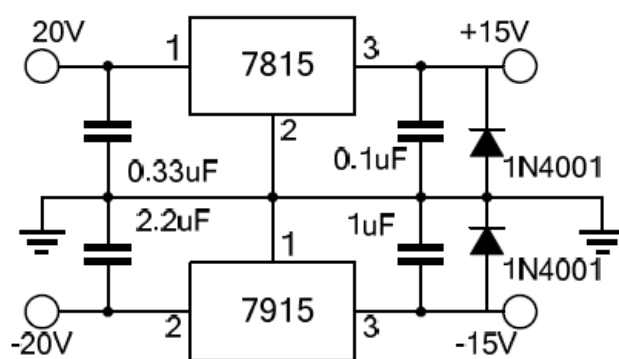

Fig.11 Split power supply (\$\pm 15\text{V}, 1\text{A}\$)

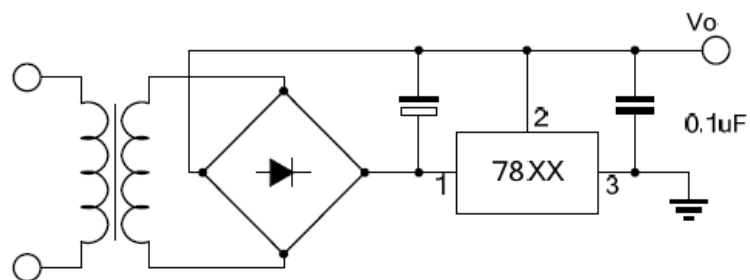

Fig.12 Negative output voltage circuit

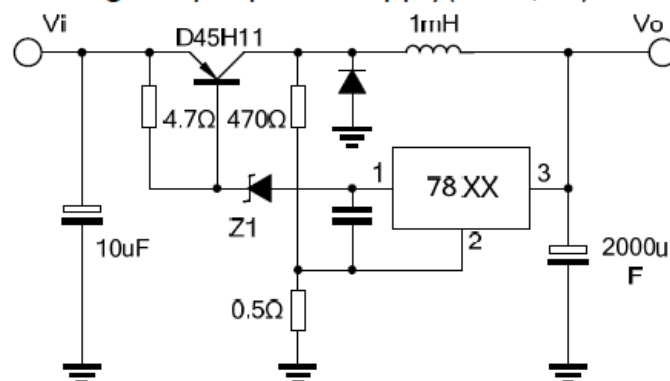

Fig.13 switching regulator

# 典型特性曲线 Typical performance characteristics

Fig.14 Quiescent current

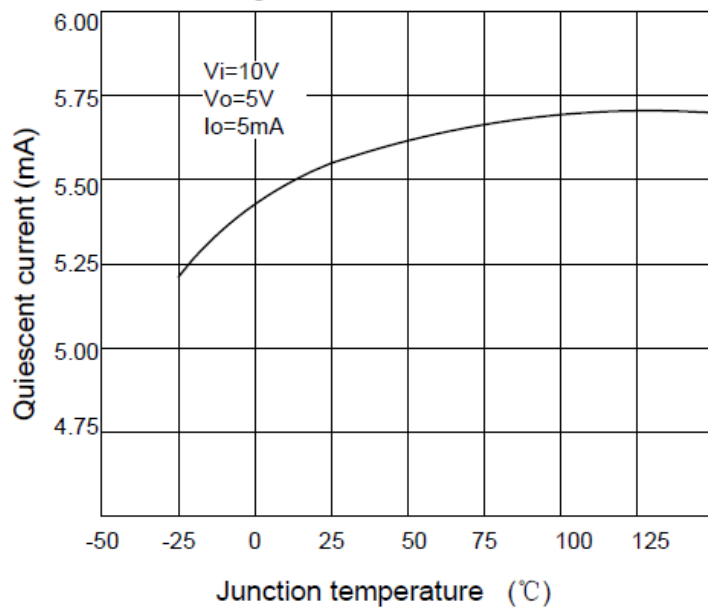

Fig.15 Output voltage

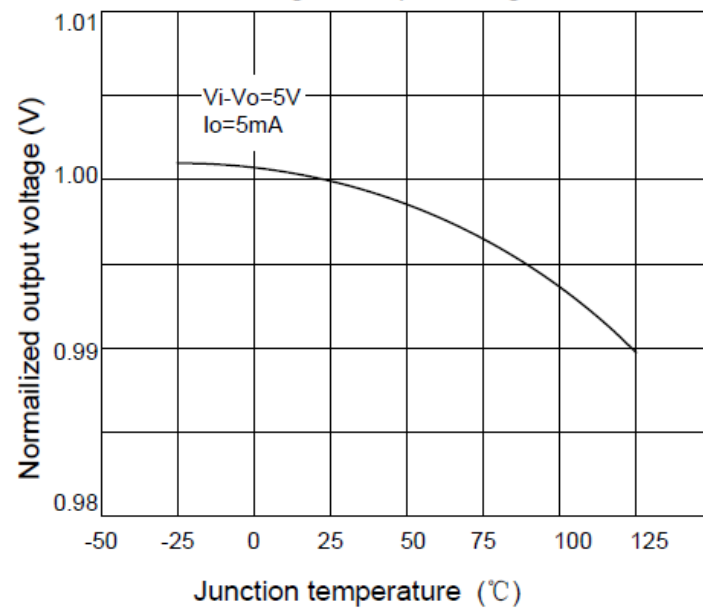

Fig.16 Peak output current

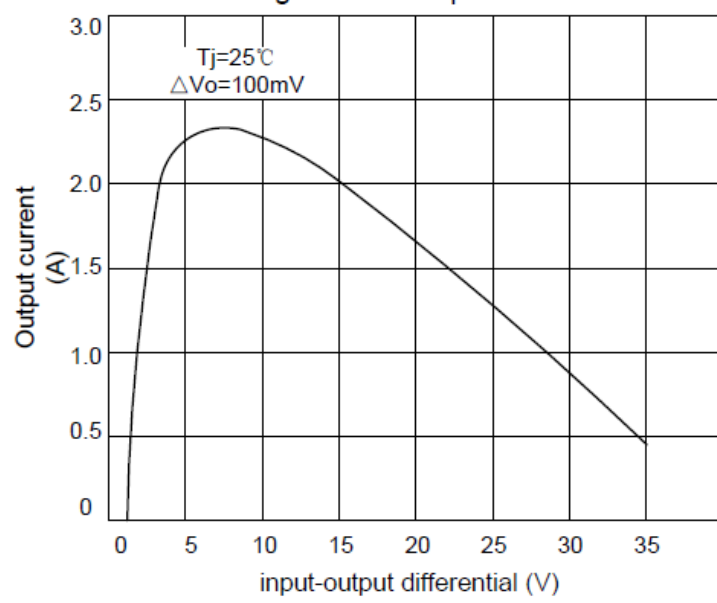
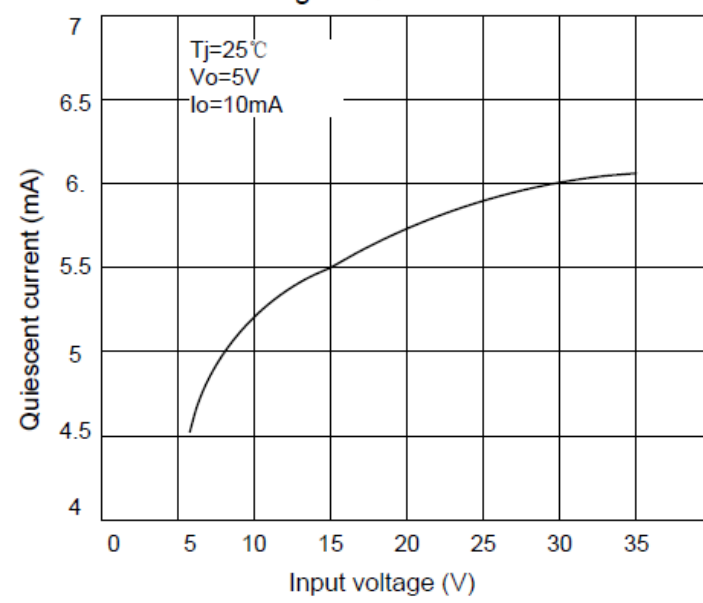
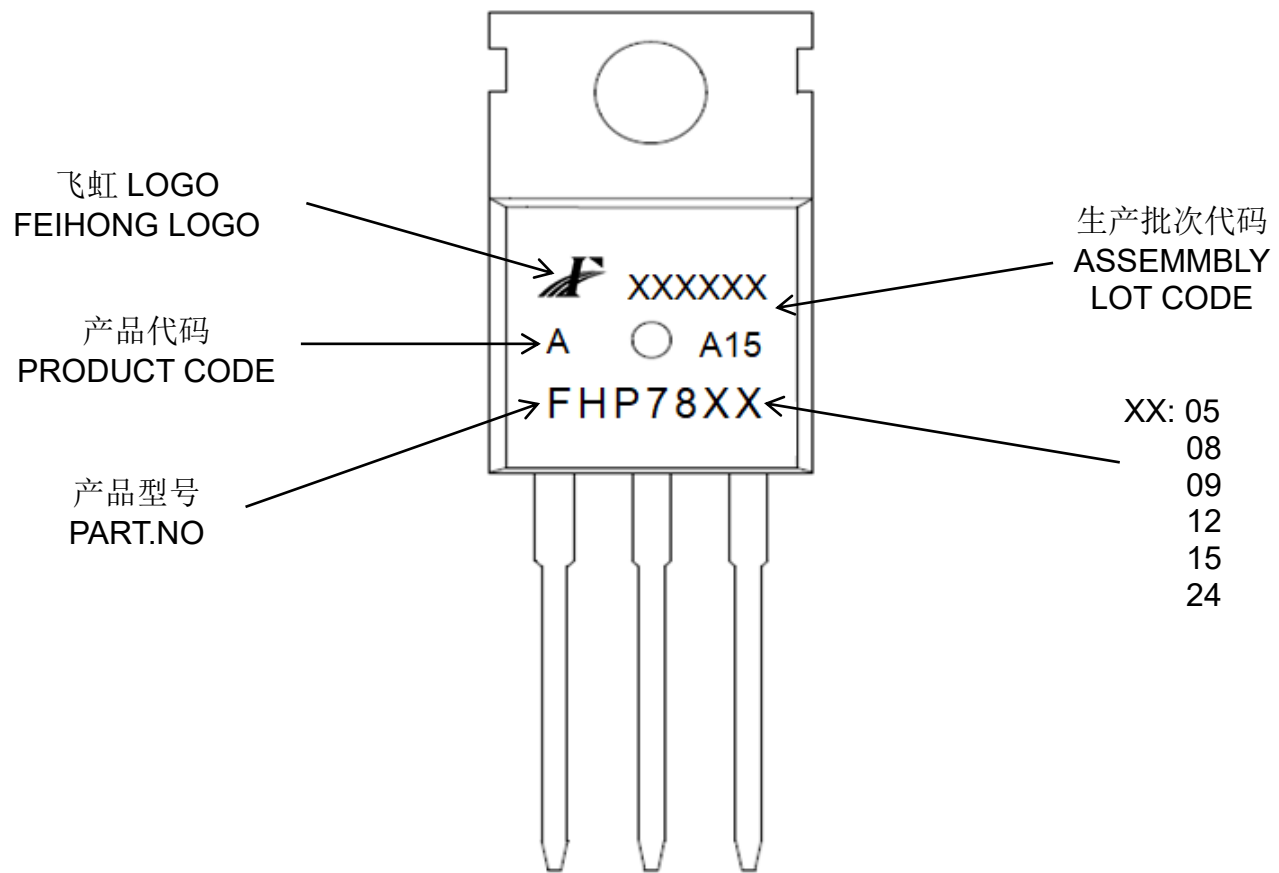

Fig.17 Quiescent current



印记 Marking:





外形尺寸:

Package Dimension:

TO-220

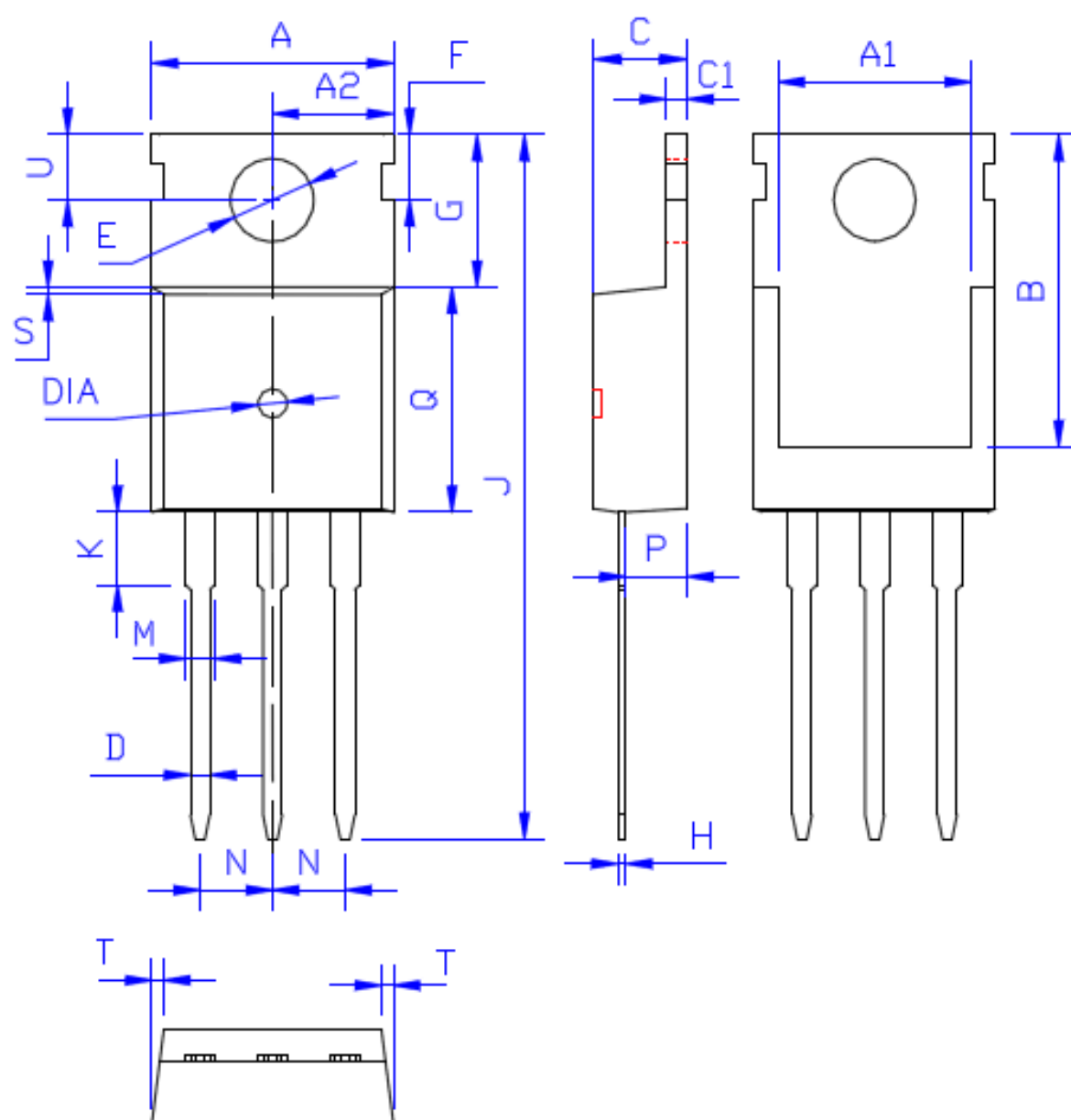

DIM	MILLIMETERS
A	10.00 ± 0.30
A1	8.00 ± 0.30
A2	5.00 ± 0.30
B	13.20 ± 0.40
C	4.50 ± 0.20
C1	1.30 ± 0.20
D	0.80 ± 0.20
E	3.60 ± 0.20
F	3.00 ± 0.30
G	6.60 ± 0.40
H	0.50 ± 0.20
J	28.88 ± 0.50
K	3.00 ± 0.30
M	1.30 ± 0.30
N	Typical 2.54
P	2.40 ± 0.40
Q	9.20 ± 0.40
S	0.25 ± 0.15
T	0.25 ± 0.15
U	2.80 ± 0.30
DIA	宽 1.50 ± 0.10 深 0.50 MAX

(Unit: mm)