

# QILSTE

CATALOGUE

2025-2026

[www.qilste.com](http://www.qilste.com)

## SMD LED

QILSTE SMD (Surface-Mount Device) LEDs offer excellent intensity performance and are highly energy efficient. We provide a comprehensive selection of SMD LEDs, available in a variety of sizes, viewing angles, color combinations, and light outputs, ensuring that all your design needs are met.



## APPLICATION



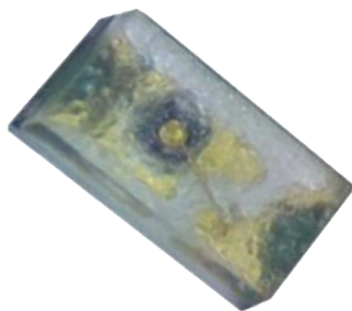

1.0\*0.5\*0.35mm

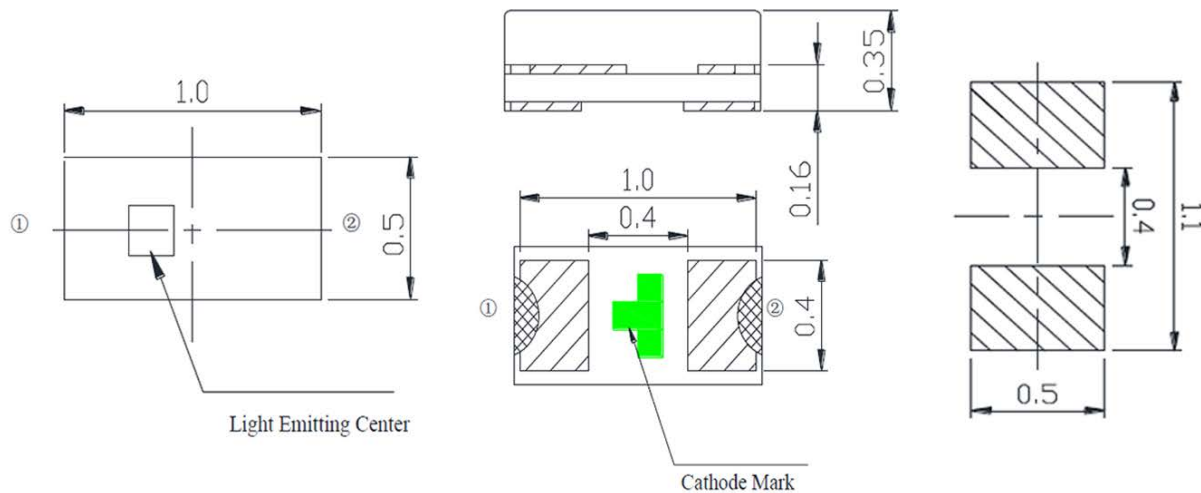





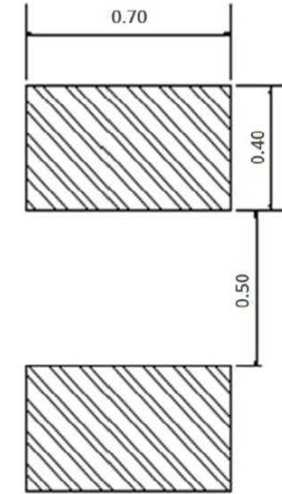
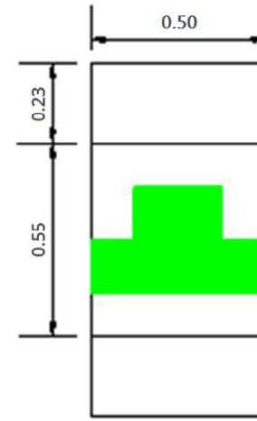
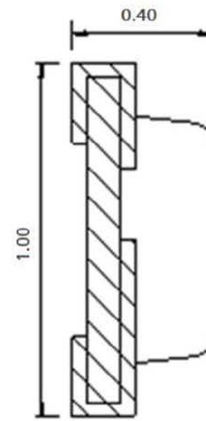
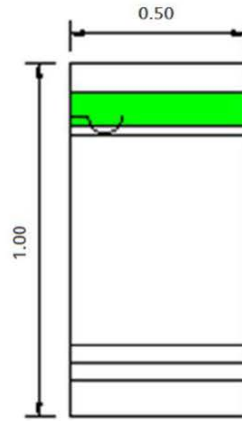

Part No.	Color	$\lambda_d(\text{nm})$ / CIE(x,y)	Typ. Luminous Intensity $I_v$ (mcd)	View Angle $2\theta$ 1/2	Typ. Forward Voltage $V_f$ (V)	Forward Current $I_f$ (mA)
H4-105PHR/5M	Red	630	24	120	2.1	5
H4-105PFO/5M	Orange	610	25	120	2.1	5
H4-105PSY/5M	Yellow	595	24	120	2.0	5
H4-105PKYG/5M	Yellow Green	574	115	120	1.9	5
H4-105PTCG/5M	True Green	520	150	120	3.0	5
H4-105PLB/5M	Blue	461	30	120	3.0	5
H4-105PB2W/5M	White	(0.27, 0.25)	100	120	3.0	5



1.0\*0.5\*0.4mm



Part No.	Color	$\lambda_d(\text{nm})$ / CIE(x,y)	Typ. Luminous Intensity $I_v$ (mcd)	View Angle $2\theta_{1/2}$	Typ. Forward Voltage $V_F$ (V)	Forward Current $I_F$ (mA)
H4-105HR	 Red	630	110	120	2.2	20
H4-105FO/5M	 Orange	610	28.5	120	2.0	5
H4-105SY/5M	 Yellow	595	28.5	120	2.0	5
H4-105KYG/5M	 Yellow Green	574	115	120	2.0	5
H4-105TCG/5M	 True Green	520	200	120	2.7	5
H4-105LB/5M	 Blue	461	35	120	2.8	5
H4-105B2W/5M	 White	(0.27, 0.25)	230	120	2.8	5



1.6\*0.8\*0.4mm

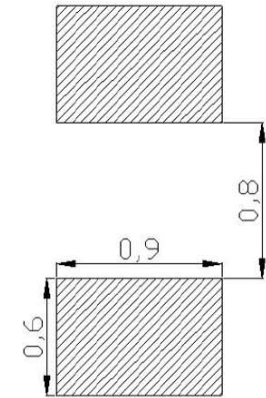
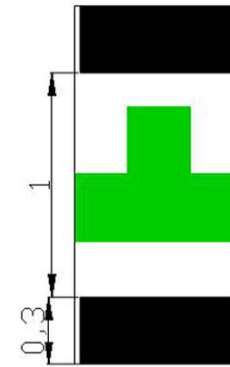
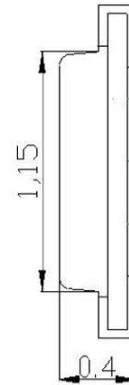
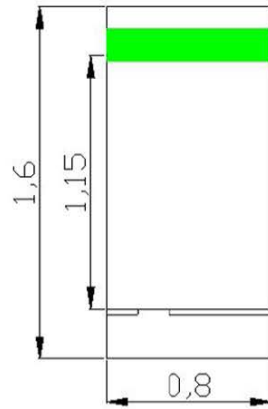





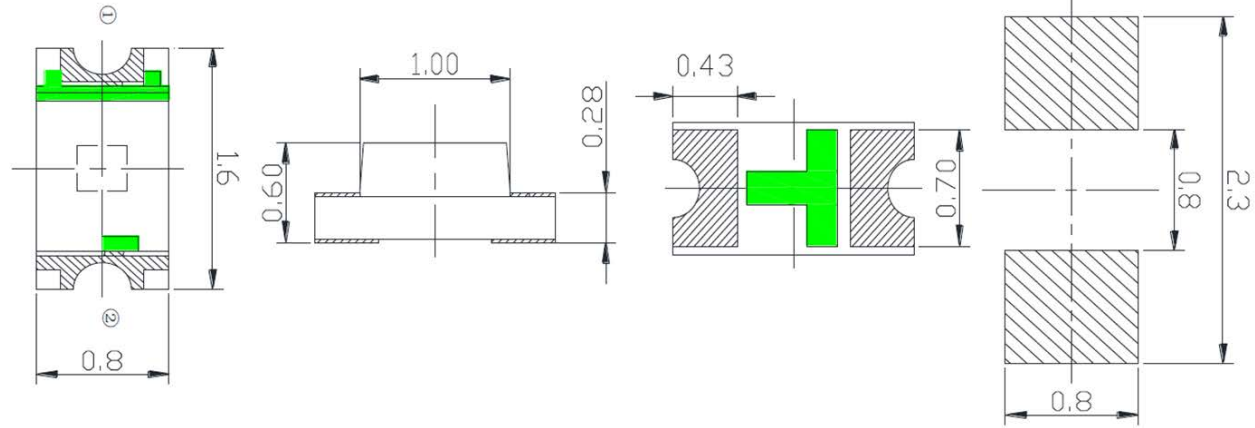

Part No.	Color	$\lambda_d(\text{nm})$ / CIE(x,y)	Typ. Luminous Intensity $I_v$ (mcd)	View Angle $2\theta$ 1/2	Typ. Forward Voltage $V_f$ (V)	Forward Current $I_f$ (mA)
H4-108ZR/5M	Red	640	18	120	2.0	5
H4-108FO/5M	Orange	611	18	120	2.1	5
H4-108SY/5M	Yellow	591	18	120	2.1	5
H4-108KYG/5M	Yellow Green	574	11.5	120	2.0	5
H4-108TCG/5M	True Green	518	285	120	2.7	5
H4-108LB/5M	Blue	461	15	120	2.8	5
H4-108B2W/5M	White	(0.25, 0.27)	71	120	3.0	5



1.6\*0.8\*0.6mm







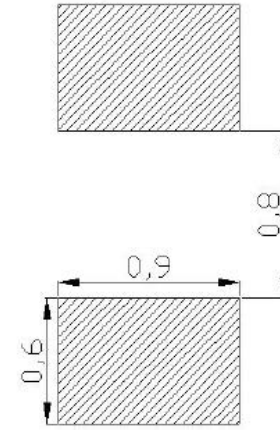
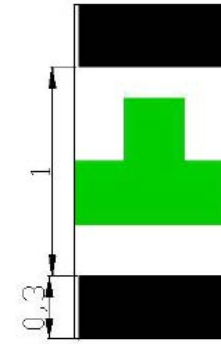
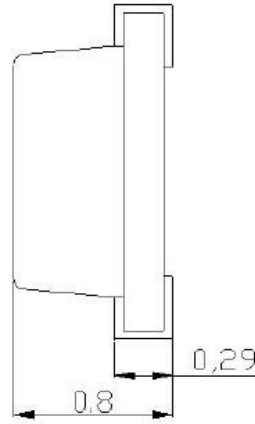
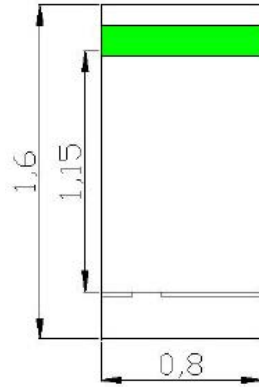

Part No.	Color	$\lambda_d$ (nm)/ CIE(x,y)	Typ. Luminous Intensity $I_v$ (mcd)	View Angle $2\theta$ 1/2	Typ. Forward Voltage $V_f$ (V)	Forward Current $I_f$ (mA)
H6-108QVR	 Red	630	140	120	2.2	20
H6-108QVO	 Orange	609	140	120	2.2	20
H6-108QVY	 Yellow	595	140	120	2.2	20
H6-108QVYG	 Yellow Green	574	35	120	2.2	20
H6-108QVTG/5M	 True Green	515	285	120	2.8	5
H6-108QVB/5M	 Blue	460	45	120	2.9	5
H6-108QB3W/5M	 White	(0.28, 0.27)	285	120	2.8	5



1.6\*0.8\*0.8mm





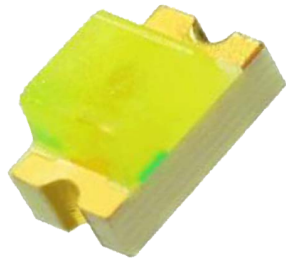

Part No.	Color	$\lambda_d(\text{nm})$ / CIE(x,y)	Typ. Luminous Intensity $I_v$ (mcd)	View Angle $2\theta$ 1/2	Typ. Forward Voltage $V_F$ (V)	Forward Current $I_F$ (mA)
H8-108HR	 Red	625	140	120	2.2	20
H8-108FO	 Orange	609	140	120	2.1	20
H8-108SY	 Yellow	595	140	120	2.2	20
H8-108KYG	 Yellow Green	574	35	120	2.2	20
H8-108TCG	 True Green	515	720	120	3.1	20
H8-108LB/5M	 Blue	460	45	120	2.8	5
H8-108B2W/5M	 White	(0.27, 0.24)	285	120	3.0	5

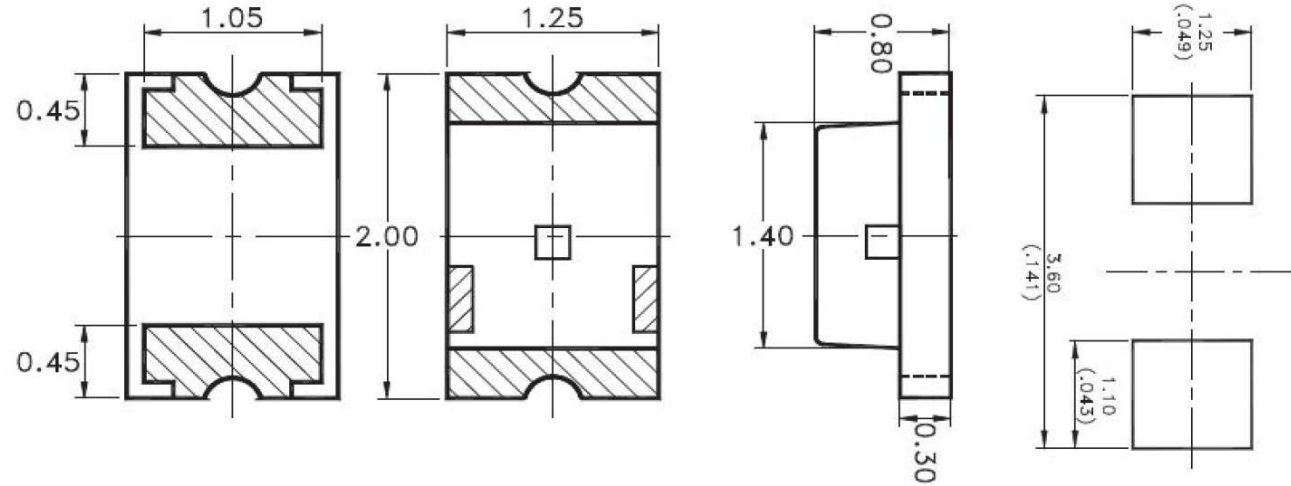

2.0\*1.25\*0.8mm







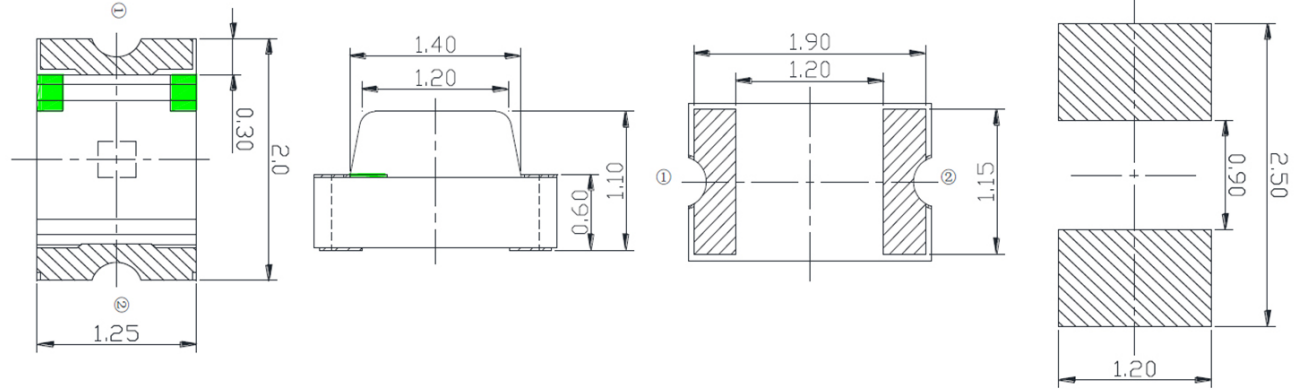

Part No.	Color	$\lambda_d$ (nm)/ CIE(x,y)	Typ. Luminous Intensity $I_v$ (mcd)	View Angle $2\theta$ 1/2	Typ. Forward Voltage $V_F$ (V)	Forward Current $I_F$ (mA)
H8-212QZR	 Red	631	71	130	2.0	20
H8-212QUO	 Orange	611	90	130	2.0	20
H8-212QUY	 Yellow	588	71	130	2.0	20
H8-212QUYG	 Yellow Green	574	35	130	2.1	20
H8-212QUB	 Blue	468	90	130	3.2	20



2.0\*1.25\*1.1mm





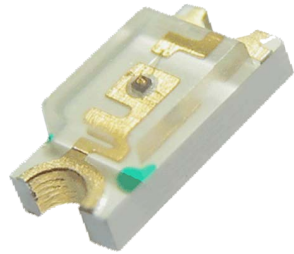

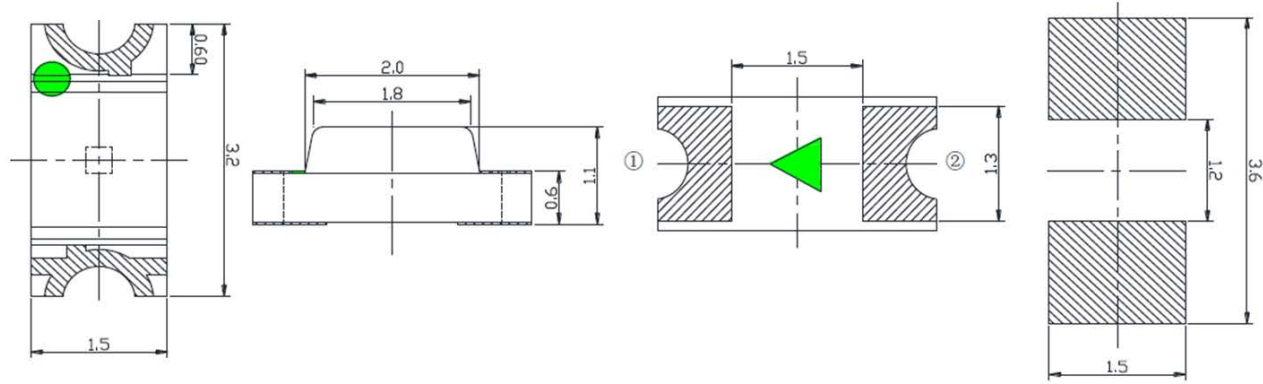

Part No.	Color	$\lambda_d(\text{nm})$ / CIE(x,y)	Typ. Luminous Intensity $I_v$ (mcd)	View Angle $2\theta$ 1/2	Typ. Forward Voltage $V_F$ (V)	Forward Current $I_F$ (mA)
H11-212QVR	 Red	630	140	120	2.2	20
H11-212QVO	 Orange	609	140	120	2.2	20
H11-212QVY	 Yellow	595	140	120	2.2	20
H11-212QVYG	 Yellow Green	570	45	120	2.2	20
H11-212QVTG/5M	 True Green	524	285	120	2.8	5
H11-212QVB/5M	 Blue	460	45	120	2.8	5
H11-212QB3W/5M	 White	(0.27, 0.26)	285	120	2.8	5



3.2\*1.5\*1.1mm





Part No.	Color	$\lambda_d(\text{nm})$ / CIE(x,y)	Typ. Luminous Intensity $I_v$ (mcd)	View Angle $2\theta_{1/2}$	Typ. Forward Voltage $V_F$ (V)	Forward Current $I_F$ (mA)
H11-316QVR	 Red	630	140	120	2.2	20
H11-316QVO	 Orange	610	140	120	2.2	20
H11-316QVY	 Yellow	595	115	120	2.2	20
H11-316QVYG	 Yellow Green	574	35	120	2.1	20
H11-316QVTG	 True Green	515	720	120	3.1	20
H11-316QVB	 Blue	460	140	120	3.2	20
H11-316QB3W/5M	 White	(0.25, 0.27)	285	120	2.9	5

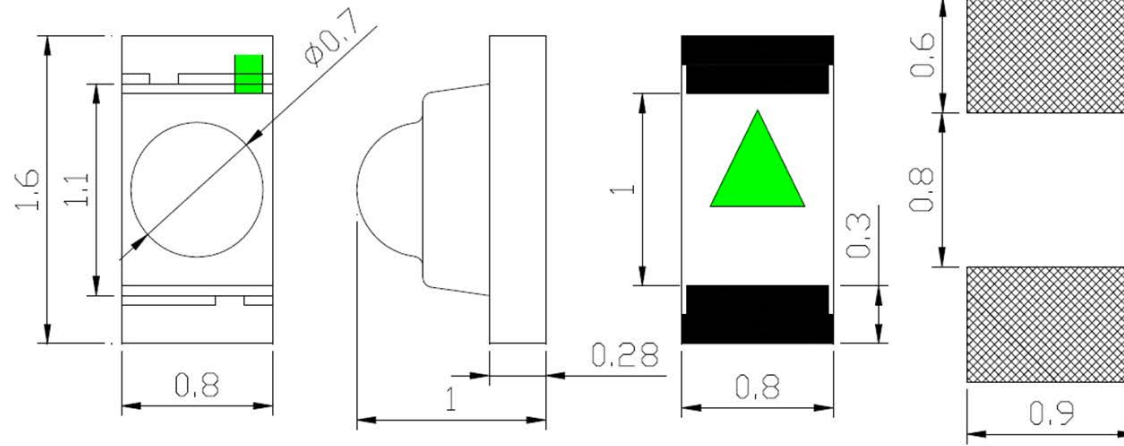

1.6\*0.8\*1.0mm



Part No.	Color	$\lambda_d(\text{nm})$ / CIE(x,y)	Typ. Luminous Intensity $I_v$ (mcd)	View Angle $2\theta_{1/2}$	Typ. Forward Voltage $V_F$ (V)	Forward Current $I_F$ (mA)
H10-T108KYG/5M	 Yellow Green	570	45	35	2.0	5
H10-T108TCG	 True Green	515	1200	35	2.9	20
H10-T108LB/5M	 Blue	460	300	35	2.9	5

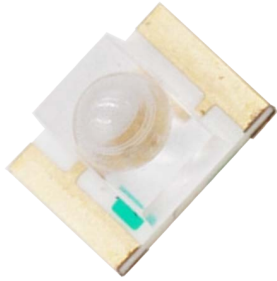

2.0\*1.25\*1.1mm

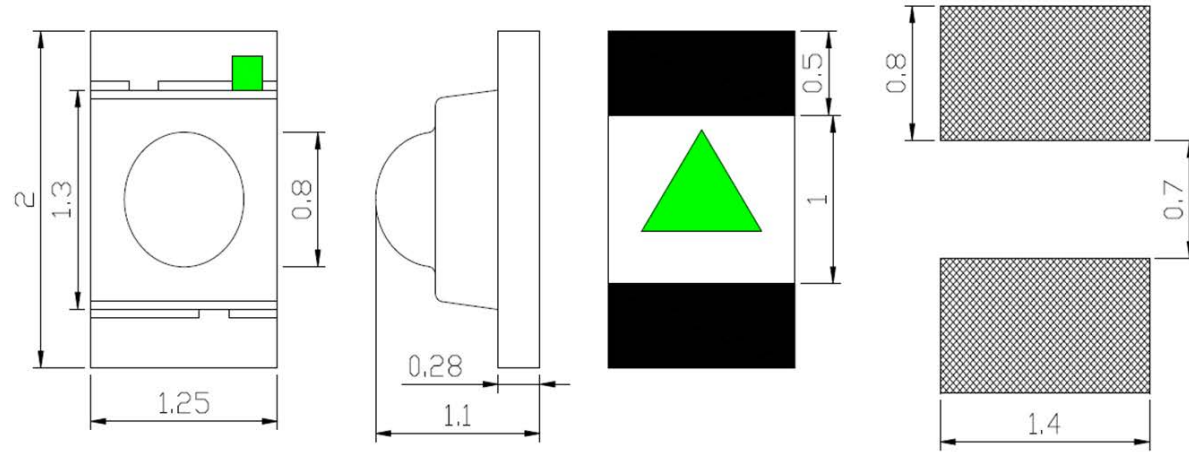



Part No.	Color	$\lambda_d(\text{nm})/$ CIE(x,y)	Typ. Luminous Intensity $I_v$ (mcd)	View Angle $2\theta_{1/2}$	Typ. Forward Voltage $V_F$ (V)	Forward Current $I_F$ (mA)
H11-T212HR	<span style="color: red;">■</span> Red	630	500	30	2.2	20
H11-T212B2W/5M	<span style="color: white;">□</span> White	(0.25, 0.27)	300	30	2.8	5

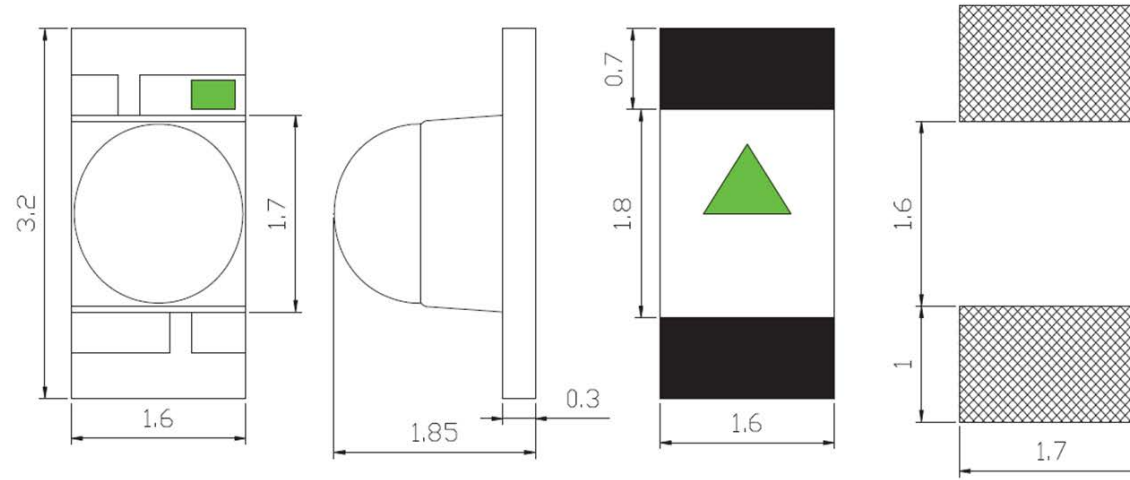

3.2\*1.6\*1.85mm







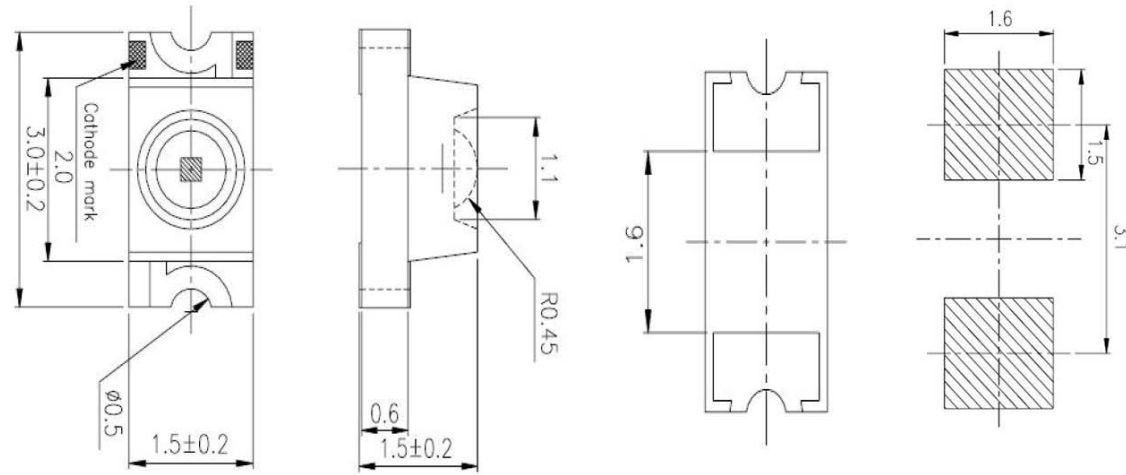

Part No.	Color	$\lambda_d(\text{nm})/$ CIE(x,y)	Typ. Luminous Intensity $I_v$ (mcd)	View Angle $2\theta_{1/2}$	Typ. Forward Voltage $V_f$ (V)	Forward Current $I_f$ (mA)
H19-T316HR	 Red	630	500	30	2.2	20
H19-T316TCG	 True Green	524	3500	35	2.8	20
H19-T316LB	 Blue	460	720	35	2.9	20







3.0\*1.5\*1.5mm

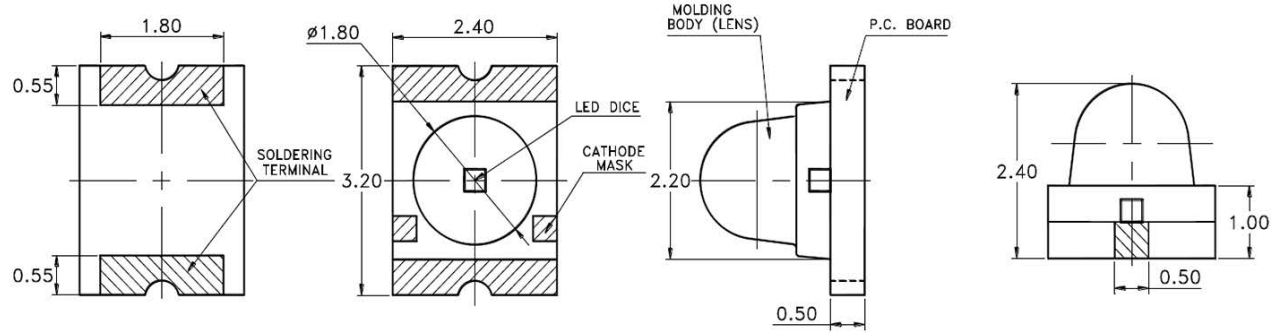

Part No.	Color	$\lambda_d(\text{nm})$ / CIE(x,y)	Typ. Luminous Intensity $I_v$ (mcd)	View Angle $2\theta_{1/2}$	Typ. Forward Voltage $V_f$ (V)	Forward Current $I_f$ (mA)
H15-A316QHR	 Red	630	360	60	2.2	20
H15-A316QFO	 Orange	610	340	60	2.2	20
H15-A316QSY	 Yellow	595	340	60	2.2	20
H15-A316QKYG	 Yellow Green	574	112	60	2.1	20
H15-A316QTCG	 True Green	518	450	60	3.1	20
H15-A316QMB	 Blue	460	180	60	3.1	20









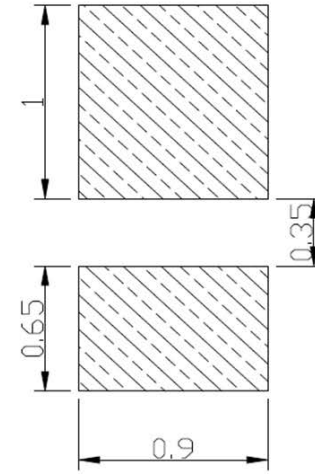
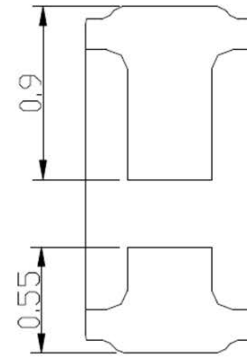
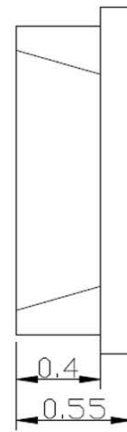
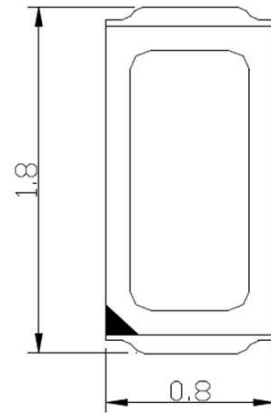

3.2\*2.4\*2.4mm

Part No.	Color	$\lambda_d(\text{nm})$ / CIE(x,y)	Typ. Luminous Intensity $I_v$ (mcd)	View Angle $2\theta_{1/2}$	Typ. Forward Voltage $V_f$ (V)	Forward Current $I_f$ (mA)
H24-T324QZR	 Red	639	850	120	2.0	20
H24-T324QFO	 Orange	610	1200	120	2.2	20
H24-T324QSY	 Yellow	588	1800	120	2.0	20
H24-T324QKYG	 Yellow Green	574	600	120	2.0	20
H24-T324QLB	 Blue	468	900	120	3.0	20



1.8\*0.8\*0.55mm



Part No.	Color	$\lambda_d(\text{nm})$ / CIE(x,y)	Typ. Luminous Intensity $I_v$ (mcd)	View Angle $2\theta_{1/2}$	Typ. Forward Voltage $V_F$ (V)	Forward Current $I_F$ (mA)
H6-M108HR	 Red	630	230	120	2.2	20
H6-M108FO	 Orange	610	210	120	2.2	20
H6-M108SY	 Yellow	592	210	120	2.2	20
H6-M108KYG	 Yellow Green	570	85	120	2.2	20
H6-M108TCG	 True Green	515	1000	120	3.2	20
H6-M108LB	 Blue	460	230	120	3.2	20
H6-M108B2W	 White	(0.28, 0.27)	2100	120	3.1	20



3.0\*2.0\*1.3mm

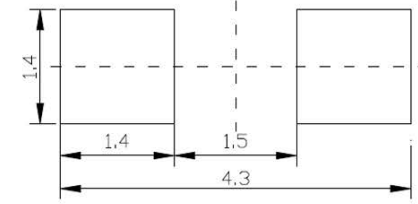
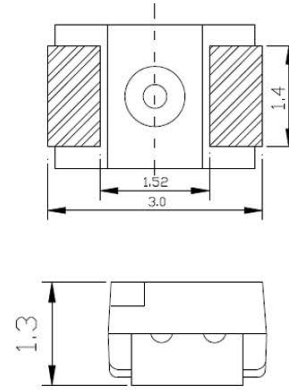
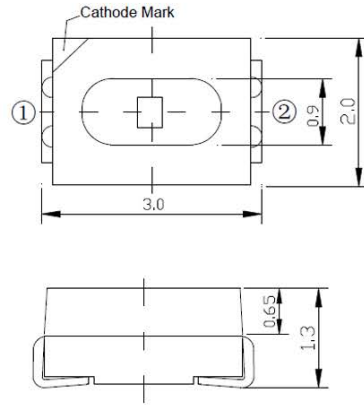





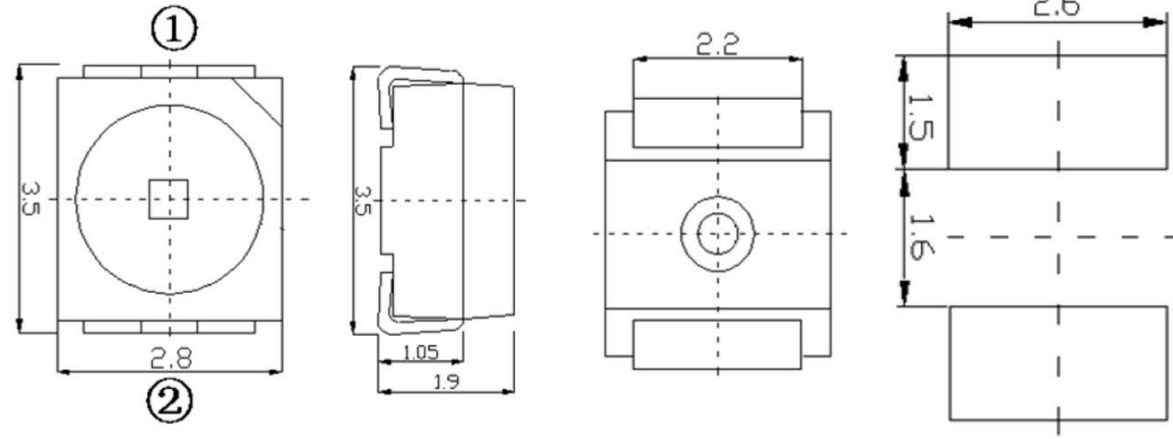

Part No.	Color	$\lambda_d(\text{nm})/\text{CIE}(x,y)$	Typ. Luminous Intensity $I_v$ (mcd)	View Angle $2\theta_{1/2}$	Typ. Forward Voltage $V_F$ (V)	Forward Current $I_F$ (mA)
H13-320HR	Red	630	285	120	2.1	20
H13-320FO	Orange	609	230	120	2.1	20
H13-320SY	Yellow	589	230	120	2.1	20
H13-320KYG	Yellow Green	574	72	120	2.1	20
H13-320TCG	True Green	521	1400	120	3.1	20
H13-320LB	Blue	460	320	120	3.1	20
H13-320B2W	White	(0.26, 0.24)	2000	120	3.1	20







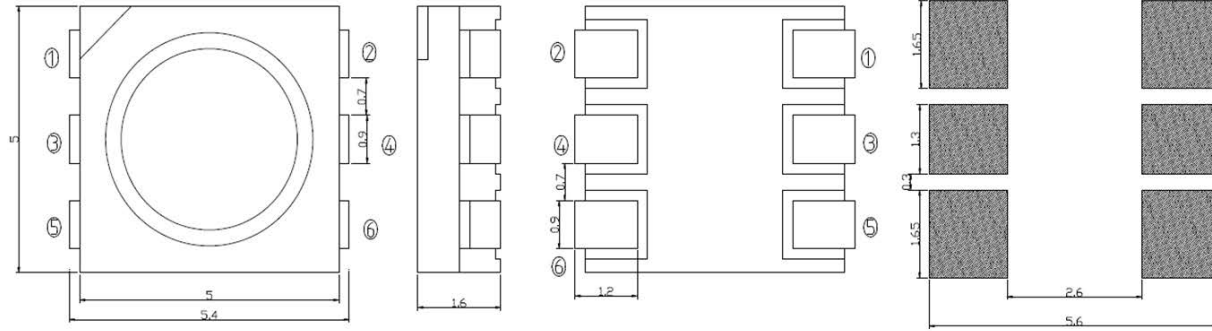

3.5\*2.8\*1.9mm



Part No.	Color	$\lambda_d(\text{nm})$ / CIE(x,y)	Typ. Luminous Intensity $I_v$ (mcd)	View Angle $2\theta_{1/2}$	Typ. Forward Voltage $V_f$ (V)	Forward Current $I_f$ (mA)
H19-328HR	 Red	625	285	120	2.1	20
H19-328FO	 Orange	609	230	120	2.1	20
H19-328SY	 Yellow	589	230	120	2.1	20
H19-328KYG	 Yellow Green	574	72	120	2.1	20
H19-328TCG	 True Green	515	1500	120	3.2	20
H19-328LB	 Blue	462	450	120	3.2	20
H19-328B2W/5M	 White	(0.26, 0.24)	600	120	2.9	5









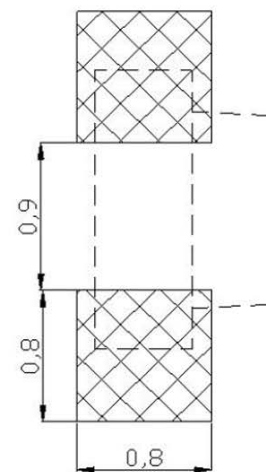
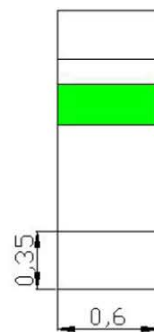
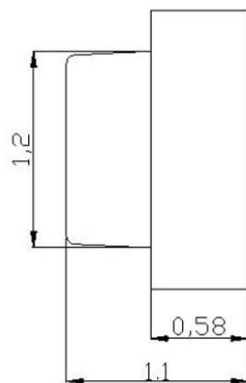
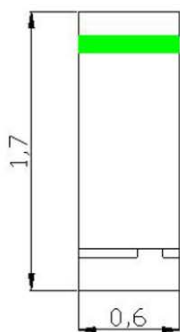

5.0\*5.4\*1.6mm

Part No.	Color	$\lambda_d(\text{nm})$ / CIE(x,y)	Typ. Luminous Intensity $I_v$ (mcd)	View Angle $2\theta_{1/2}$	Typ. Forward Voltage $V_F$ (V)	Forward Current $I_F$ (mA)
H16-554HR	 Red	625	800	120	2.2	60
H16-554FO	 Orange	610	800	120	2.2	60
H16-554SY	 Yellow	595	950	120	2.2	60
H16-554TCG	 True Green	518	3200	120	3.2	60
H16-554LB	 Blue	472	1800	120	3.2	60
H16-554B2W	 White	(0.275, 0.27)	7500	120	3.2	60



1.7\*0.6\*1.1mm







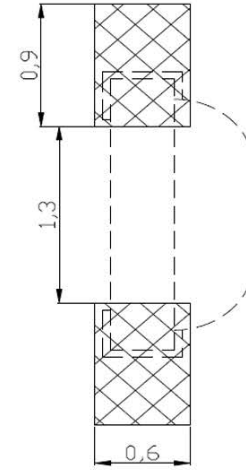
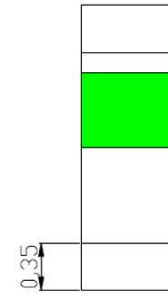
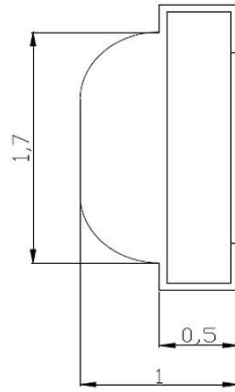
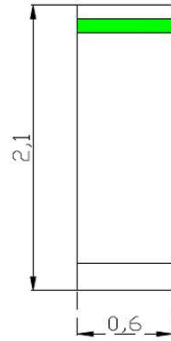

Part No.	Color	$\lambda_d(\text{nm})$ / CIE(x,y)	Typ. Luminous Intensity $I_v$ (mcd)	View Angle $2\theta_{1/2}$	Typ. Forward Voltage $V_F$ (V)	Forward Current $I_F$ (mA)
H6-C111HR	 Red	630	140	120	2.1	20
H6-C111FO/5M	 Orange	609	35	120	2.0	5
H6-C111SY/5M	 Yellow	595	35	120	2.0	5
H6-C111KYG/5M	 Yellow Green	574	9	120	2.0	5
H6-C111TCG	 True Green	515	900	120	3.2	20
H6-C111LB/5M	 Blue	460	45	120	2.8	5
H6-C111B2W/5M	 White	(0.25, 0.27)	230	120	2.8	5



2.1\*0.6\*1.0mm







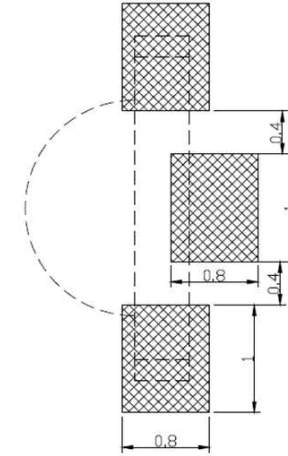
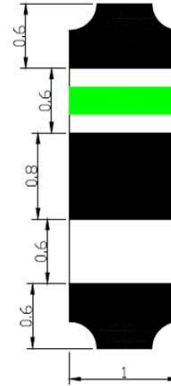
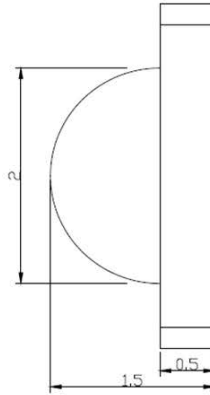
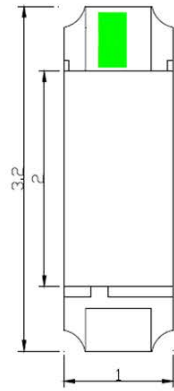

Part No.	Color	$\lambda_d(\text{nm})$ / CIE(x,y)	Typ. Luminous Intensity $I_v$ (mcd)	View Angle $2\theta$ 1/2	Typ. Forward Voltage $V_f$ (V)	Forward Current $I_f$ (mA)
H6-C210HR	 Red	630	140	120	2.1	20
H6-C210FO/5M	 Orange	609	35	120	2.1	5
H6-C210SY/5M	 Yellow	595	35	120	2.1	5
H6-C210KYG/5M	 Yellow Green	570	11	120	2.1	5
H6-C210TCG/5M	 True Green	521	210	120	2.8	5
H6-C210LB/5M	 Blue	460	45	120	2.8	5
H6-C210B2W/5M	 White	(0.27, 0.25)	230	120	2.8	5



3.2\*1.0\*1.5mm







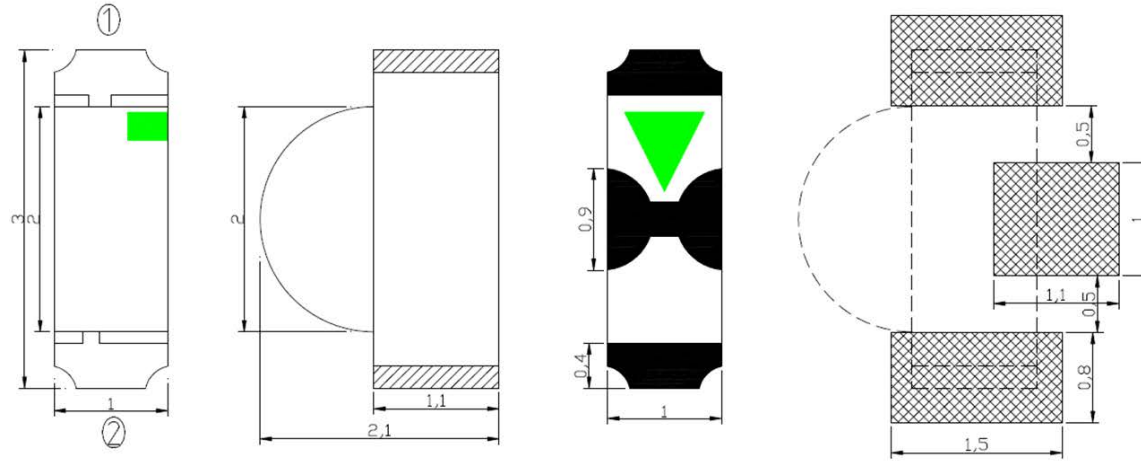

Part No.	Color	$\lambda_d(\text{nm})$ / CIE(x,y)	Typ. Luminous Intensity $I_v$ (mcd)	View Angle $2\theta_{1/2}$	Typ. Forward Voltage $V_F$ (V)	Forward Current $I_F$ (mA)
H10-C315QHR	 Red	630	140	120	2.1	20
H10-C315QFO	 Orange	609	115	120	2.1	20
H10-C315QSY	 Yellow	590	140	120	2.1	20
H10-C315QKYG	 Yellow Green	574	35	120	2.1	20
H10-C315QTCG	 True Green	515	720	120	3.1	20
H10-C315QLB/5M	 Blue	460	45	120	2.8	5
H10-C315QB2W/5M	 White	(0.25, 0.27)	285	120	2.8	5



3.0\*1.0\*2.1mm







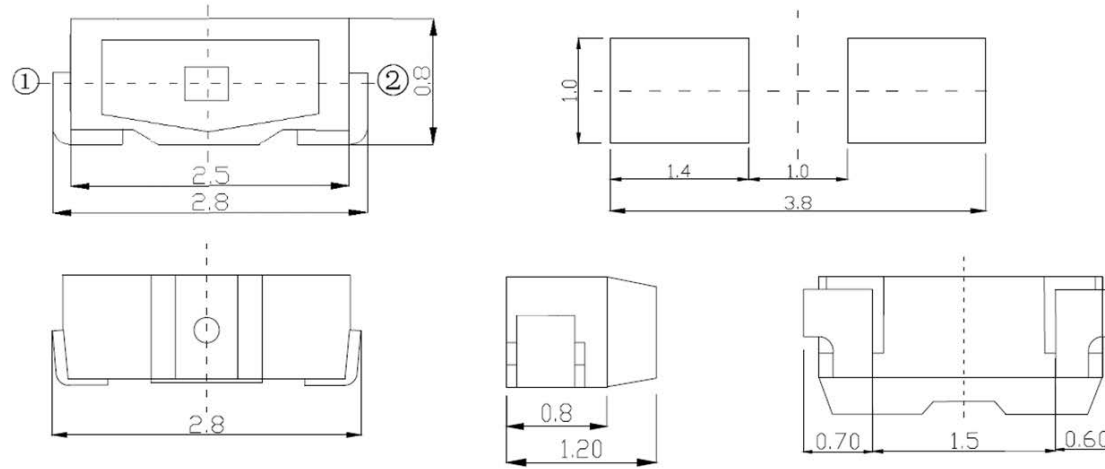

Part No.	Color	$\lambda_d(\text{nm})$ / CIE(x,y)	Typ. Luminous Intensity $I_v$ (mcd)	View Angle $2\theta_{1/2}$	Typ. Forward Voltage $V_f$ (V)	Forward Current $I_f$ (mA)
H10-C321QHR	 Red	620	140	120	2.1	20
H10-C321QFO/5M	 Orange	615	35	120	2.1	5
H10-C321QSY	 Yellow	590	140	120	2.1	20
H10-C321QKYG	 Yellow Green	574	35	120	2.1	20
H10-C321QTCG/5M	 True Green	515	240	120	2.8	5
H10-C321QLB/5M	 Blue	460	45	120	2.8	5
H10-C321QB2W	 White	(0.25, 0.27)	600	120	3.2	20



2.8\*0.8\*1.2mm



Part No.	Color	$\lambda_d(\text{nm})/\text{CIE}(x,y)$	Typ. Luminous Intensity $I_v$ (mcd)	View Angle $2\theta_{1/2}$	Typ. Forward Voltage $V_F$ (V)	Forward Current $I_F$ (mA)
H8-C212HR	 Red	630	140	120	2.1	20
H8-C212FO	 Orange	609	180	120	2.1	20
H8-C212SY	 Yellow	590	180	120	2.0	20
H8-C212KYG	 Yellow Green	574	115	120	2.1	20
H8-C212TCG	 True Green	521	720	120	3.1	20
H8-C212LB	 Blue	467	285	120	3.1	20
H8-C212B2W	 White	(0.27, 0.26)	2000	120	3.1	20





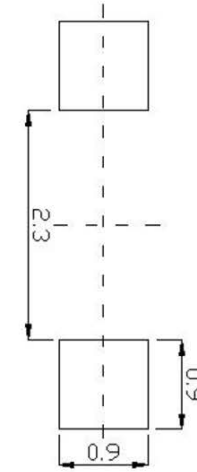
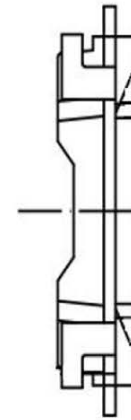
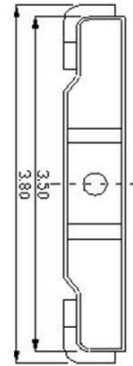
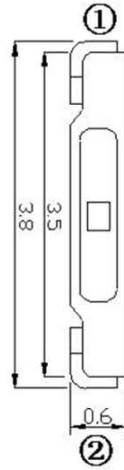

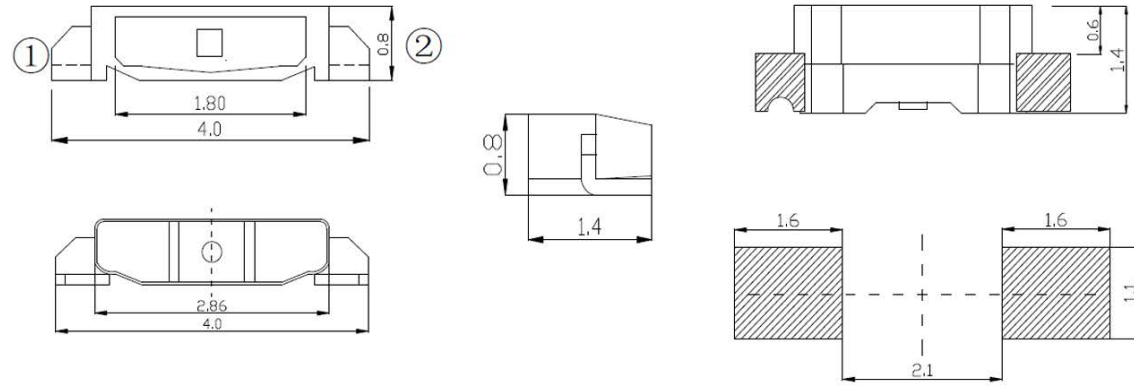

3.8\*0.6\*1.0mm



Part No.	Color	$\lambda_d(\text{nm})$ / CIE(x,y)	Typ. Luminous Intensity $I_v$ (mcd)	View Angle $2\theta_{1/2}$	Typ. Forward Voltage $V_F$ (V)	Forward Current $I_F$ (mA)
H6-C310HR	Red	625	180	120	2.1	20
H6-C310FO	Orange	609	285	120	2.1	20
H6-C310SY	Yellow	592	180	120	2.1	20
H6-C310KYG	Yellow Green	574	72	120	2.1	20
H6-C310TCG	True Green	521	1150	120	3.1	20
H6-C310LB	Blue	467	350	120	3.1	20
H6-C310B2W	White	(0.27, 0.26)	2300	120	3.1	20



4.0\*1.4\*0.8mm

Part No.	Color	$\lambda_d(\text{nm})$ / CIE(x,y)	Typ. Luminous Intensity $I_v$ (mcd)	View Angle $2\theta$ 1/2	Typ. Forward Voltage $V_f$ (V)	Forward Current $I_f$ (mA)
H8-C414HR	 Red	630	180	120	2.1	20
H8-C414FO	 Orange	609	180	120	2.1	20
H8-C414SY	 Yellow	590	180	120	2.1	20
H8-C414KYG	 Yellow Green	574	72	120	2.1	20
H8-C414TCG	 True Green	518	1100	120	3.2	20
H8-C414LB	 Blue	467	350	120	3.1	20
H8-C414B2W	 White	(0.27, 0.24)	2000	120	3.1	20

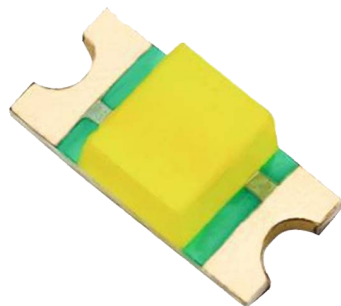

3.2\*1.25\*1.1mm

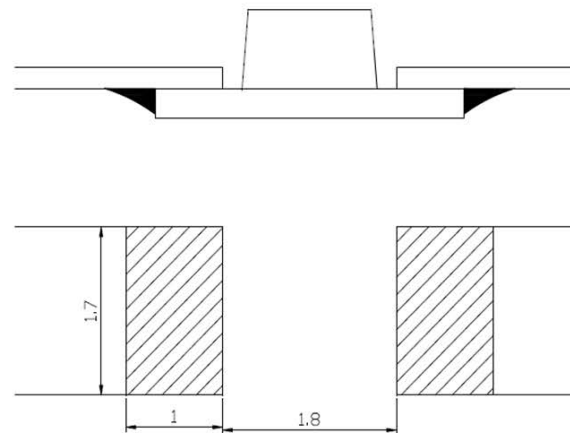
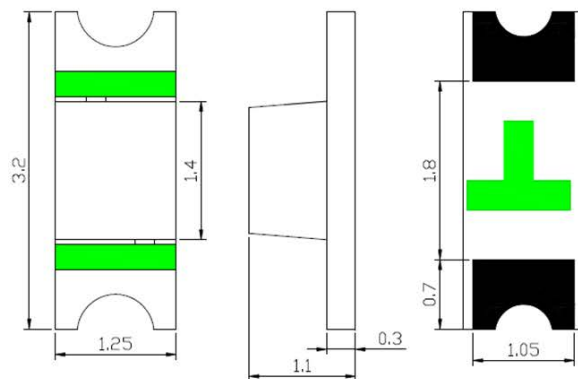



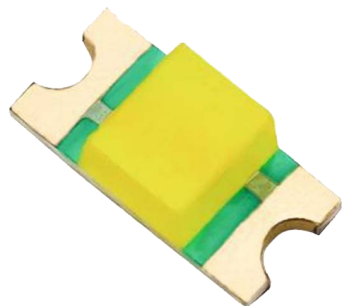

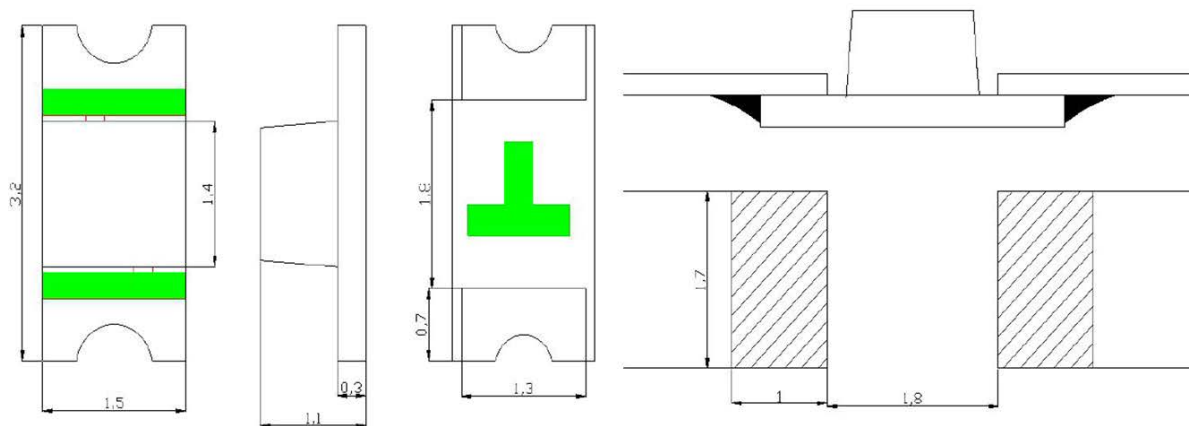

Part No.	Color	$\lambda_d(\text{nm})$ / CIE(x,y)	Typ. Luminous Intensity $I_v$ (mcd)	View Angle $2\theta_{1/2}$	Typ. Forward Voltage $V_F$ (V)	Forward Current $I_F$ (mA)
H11-F312QHR	Red	625	120	120	2.1	20
H11-F312QFO	Orange	609	115	120	2.1	20
H11-F312QSY	Yellow	590	115	120	2.1	20
H11-F312QKYG	Yellow Green	574	35	120	2.1	20
H11-F312QTCG/5M	True Green	524	230	120	2.8	5
H11-F312QLB/5M	Blue	467	45	120	2.8	5
H11-F312QB2W/5M	White	(0.29, 0.30)	180	120	2.9	5



3.2\*1.5\*1.1mm



Part No.	Color	$\lambda_d(\text{nm})$ / CIE(x,y)	Typ. Luminous Intensity $I_v$ (mcd)	View Angle $2\theta$ 1/2	Typ. Forward Voltage $V_f$ (V)	Forward Current $I_f$ (mA)
H11-F315QHR	 Red	630	140	120	2.1	20
H11-F315QFO	 Orange	610	115	120	2.1	20
H11-F315QSY	 Yellow	590	115	120	2.1	20
H11-F315QKYG	 Yellow Green	570	35	120	2.1	20
H11-F315QTCG/5M	 True Green	524	230	120	2.8	5
H11-F315QLB/5M	 Blue	467	45	120	2.9	5
H11-F315QB2W/5M	 White	(0.27, 0.25)	285	120	3.2	5

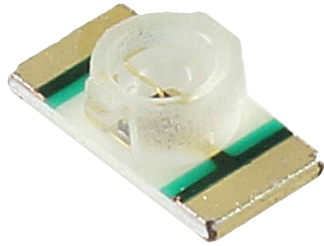

3.2\*1.6\*1.1mm

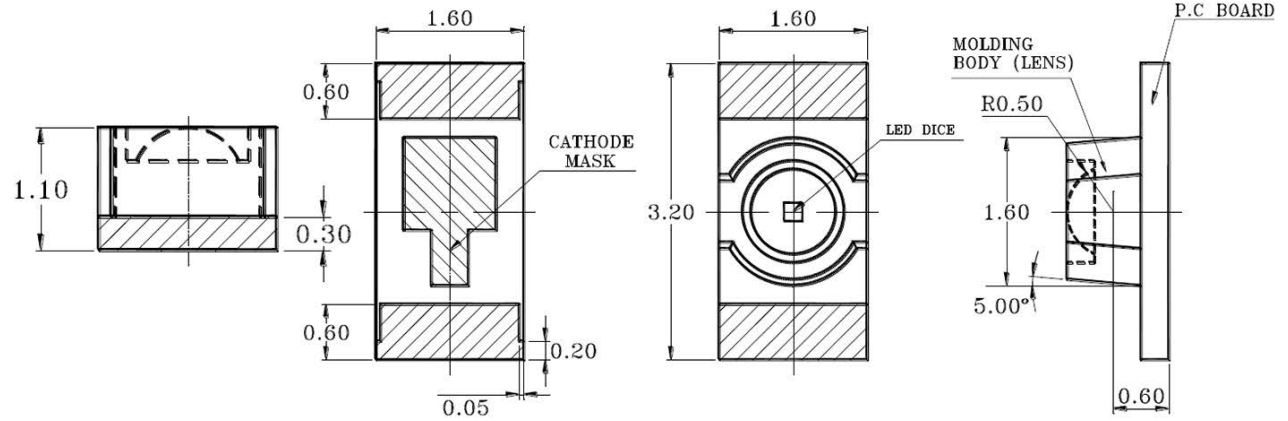

Part No.	Color	$\lambda_d(\text{nm})$ / CIE(x,y)	Typ. Luminous Intensity $I_v$ (mcd)	View Angle $2\theta_{1/2}$	Typ. Forward Voltage $V_f$ (V)	Forward Current $I_f$ (mA)
H11-AF316ZR	Red	639	100	70	2.0	20
H11-AF316FO	Orange	605	180	70	2.0	20
H11-AF316SY	Yellow	588	112	70	2.0	20
H11-AF316KYG	Yellow Green	574	112	70	2.1	20
H11-AF316TCG	True Green	530	450	70	3.2	20
H11-AF316LB	Blue	468	140	70	3.0	20
H11-AF316B2W	White	(0.29, 0.295)	337	70	3.0	20



1.6\*0.8\*0.55mm

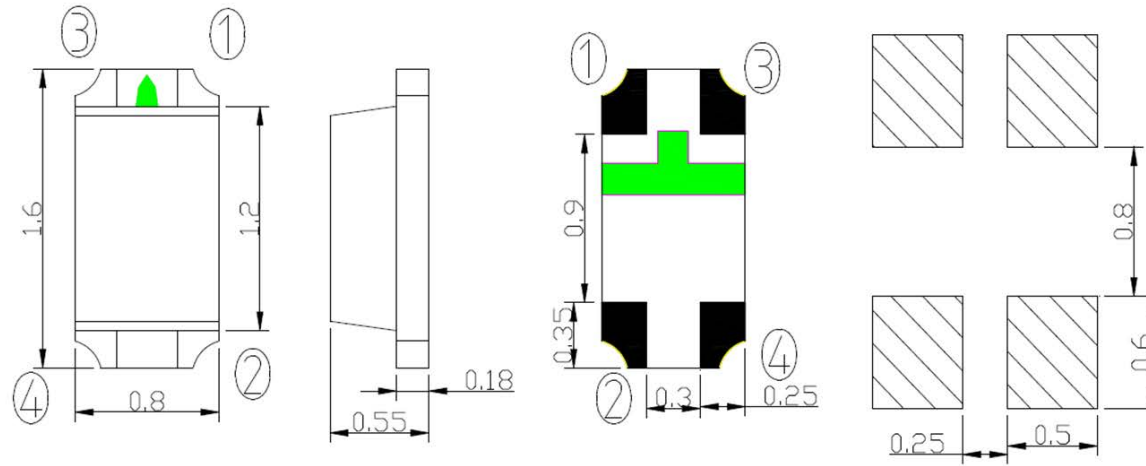

Part No.	Color	$\lambda_d(\text{nm})$ / CIE(x,y)	Typ. Luminous Intensity $I_v$ (mcd)	View Angle $2\theta_{1/2}$	Typ. Forward Voltage $V_f$ (V)	Forward Current $I_f$ (mA)
H6-D108HRB2W/5M	<span style="color: red;">■</span> Red	630	35	120	2.1	5
	<span style="color: white;">■</span> White	(0.27, 0.26)	210	120	2.9	5
H6-D108FOB2W	<span style="color: orange;">■</span> Orange	610	105	120	2.2	20
	<span style="color: white;">■</span> White	(0.3, 0.3)	285	120	3.0	20
H6-D108HRSY	<span style="color: red;">■</span> Red	633	145	120	2.1	20
	<span style="color: yellow;">■</span> Yellow	598	100	120	2.1	20

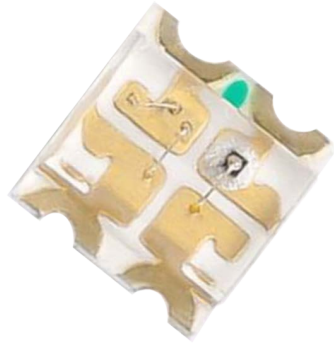

1.6\*1.5\*0.4mm

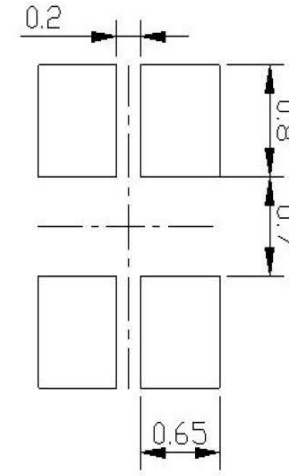
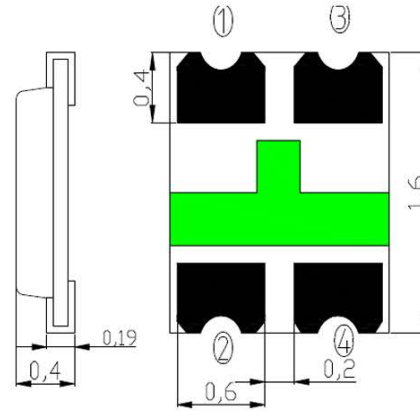
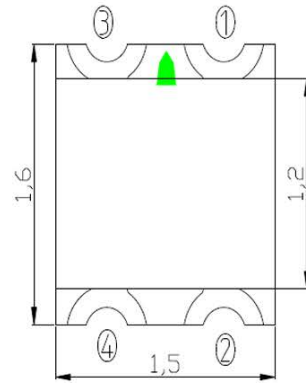

Part No.	Color	$\lambda_d(\text{nm})$ / CIE(x,y)	Typ. Luminous Intensity $I_v$ (mcd)	View Angle $2\theta_{1/2}$	Typ. Forward Voltage $V_F$ (V)	Forward Current $I_F$ (mA)
H4-S115HRKYG	<span style="color: red;">■</span> Red	625	90	120	2.1	20
	<span style="color: yellow;">■</span> Yellow Green	570	30	120	2.1	20
H4-S115HRTCG/5M	<span style="color: red;">■</span> Red	630	35	120	2.1	5
	<span style="color: green;">■</span> True Green	518	230	120	2.8	5

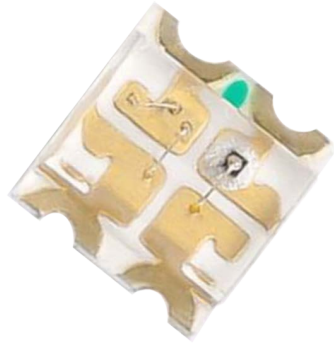

1.6\*1.5\*0.55mm

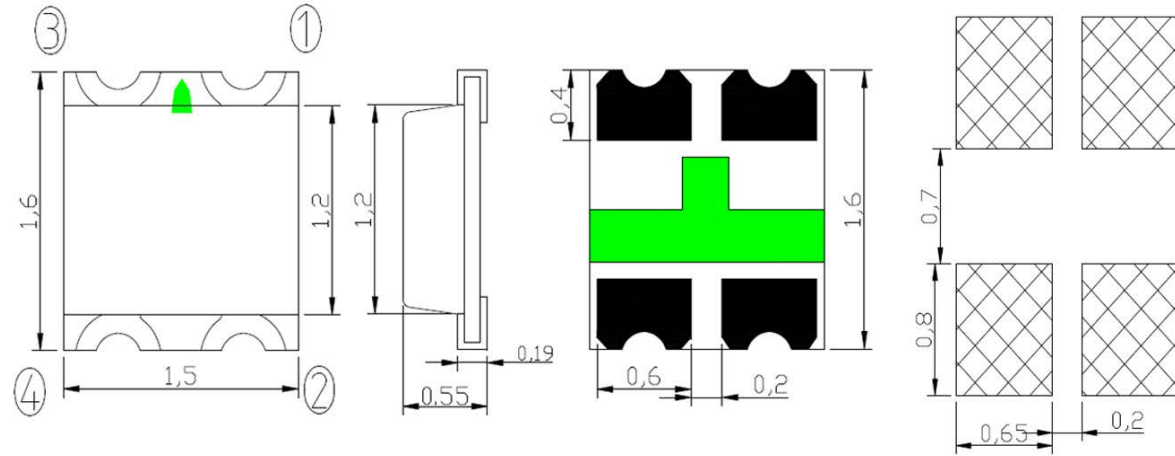

Part No.	Color	$\lambda_d(\text{nm})$ / CIE(x,y)	Typ. Luminous Intensity $I_v$ (mcd)	View Angle $2\theta_{1/2}$	Typ. Forward Voltage $V_F$ (V)	Forward Current $I_F$ (mA)
H6-S115FOB2W/5M	Orange	610	35	120	2.1	5
	White	(0.3, 0.3)	285	120	2.9	5
H6-S115LBKYG/5M	Blue	460	35	120	2.8	5
	Yellow Green	572	12	120	2.1	5
H6-S115SYKYG	Yellow	589	110	120	2.2	20
	Yellow Green	571	38	120	2.2	20



2.0\*1.25\*1.1mm

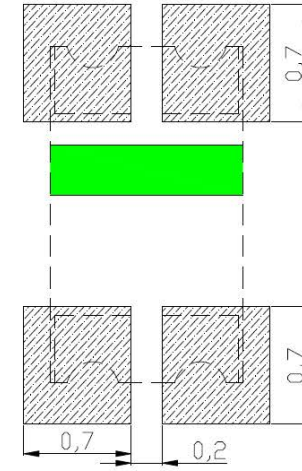
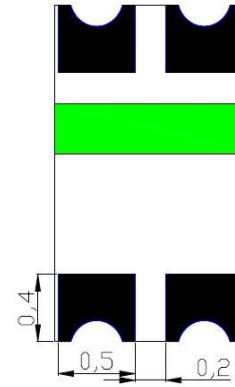
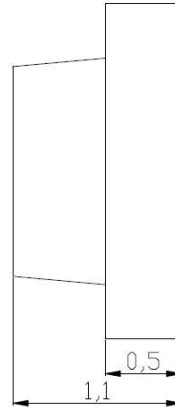
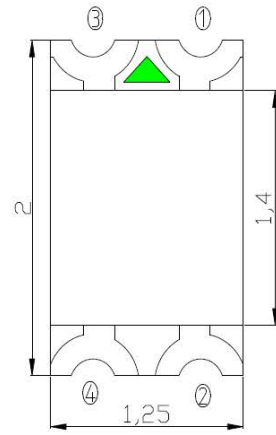

Part No.	Color	$\lambda_d(\text{nm})$ / CIE(x,y)	Typ. Luminous Intensity $I_v$ (mcd)	View Angle $2\theta_{1/2}$	Typ. Forward Voltage $V_f$ (V)	Forward Current $I_f$ (mA)
H11-D212HRTCG/5M	<span style="color: red;">■</span> Red	630	35	120	2.1	5
	<span style="color: green;">■</span> True Green	521	250	120	2.7	5
H11-D212LBTCG/5M	<span style="color: blue;">■</span> Blue	460	35	120	2.8	5
	<span style="color: green;">■</span> True Green	515	240	120	2.8	5

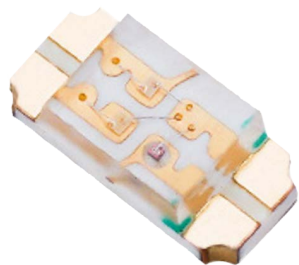

3.2\*1.5\*1.1mm

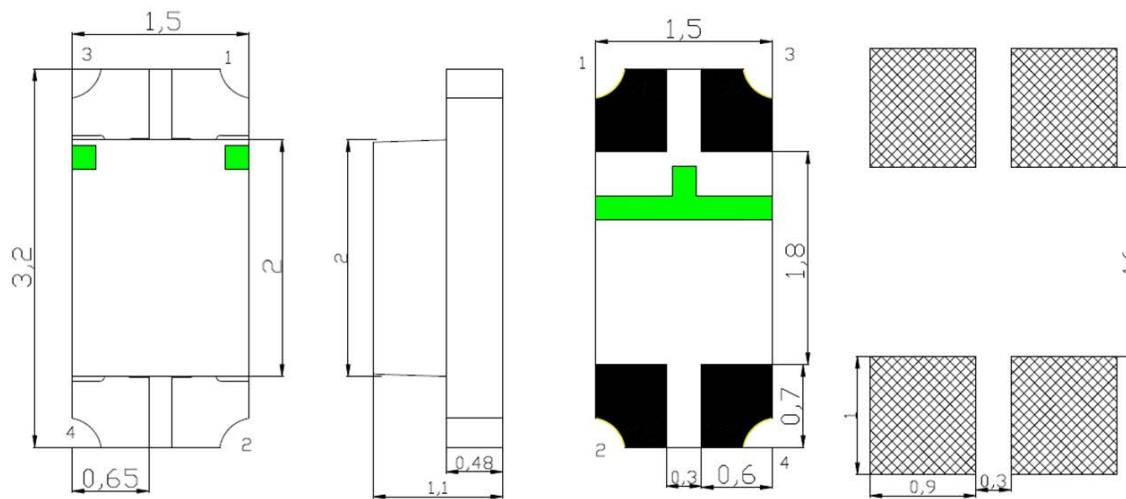

Part No.	Color	$\lambda_d(\text{nm})/\text{CIE}(x,y)$	Typ. Luminous Intensity $I_v$ (mcd)	View Angle $2\theta_{1/2}$	Typ. Forward Voltage $V_f$ (V)	Forward Current $I_f$ (mA)
H11-D316HRTCG	<span style="color: red;">■</span> Red	615	140	120	2.1	20
	<span style="color: green;">■</span> True Green	515	720	120	3.2	20
H11-D316HRSY	<span style="color: red;">■</span> Red	630	115	120	2.1	20
	<span style="color: yellow;">■</span> Yellow	595	115	120	2.1	20



3.2\*2.7\*1.1mm

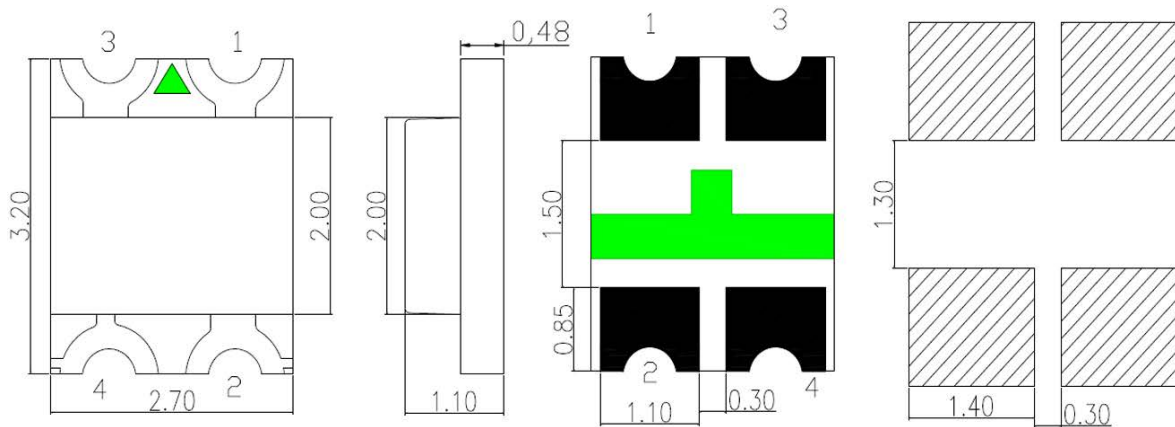





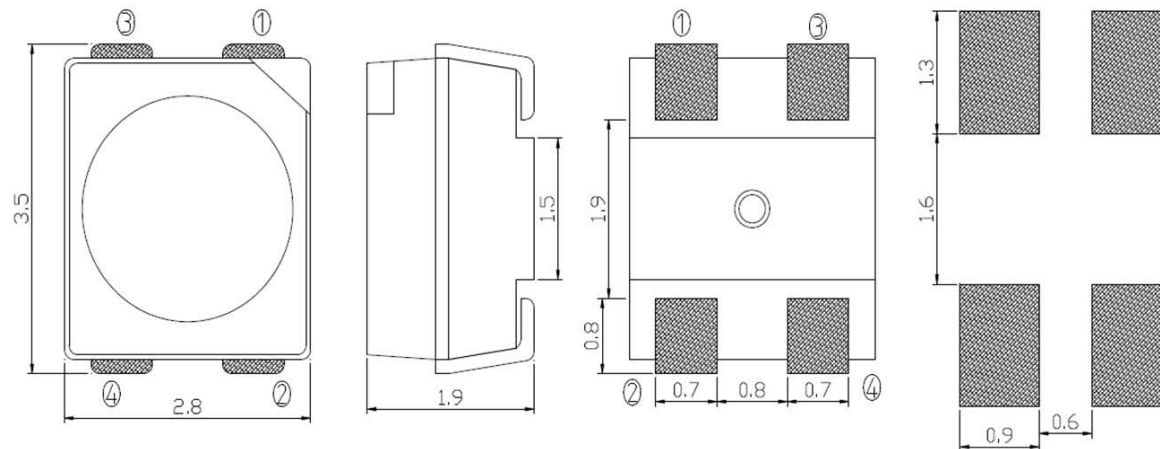

Part No.	Color	$\lambda_d(\text{nm})$ / CIE(x,y)	Typ. Luminous Intensity $I_v$ (mcd)	View Angle $2\theta_{1/2}$	Typ. Forward Voltage $V_f$ (V)	Forward Current $I_f$ (mA)
H11-S327HRB2W/5M	<span style="color: red;">■</span> Red	630	42	120	2.1	5
	<span style="color: white;">■</span> White	(0.27, 0.25)	290	120	2.8	5
H11-S327LBKYG	<span style="color: blue;">■</span> Blue	460	140	120	3.2	20
	<span style="color: yellow;">■</span> Yellow Green	572	45	120	2.2	20
H11-S327TCGLB	<span style="color: green;">■</span> True Green	515	720	120	3.2	20
	<span style="color: blue;">■</span> Blue	460	150	120	3.2	20



3.5\*2.8\*1.9mm



Part No.	Color	$\lambda_d(\text{nm})$ / CIE(x,y)	Typ. Luminous Intensity $I_v$ (mcd)	View Angle $2\theta_{1/2}$	Typ. Forward Voltage $V_f$ (V)	Forward Current $I_f$ (mA)
H19-S328HRTCG	 Red	630	240	120	2.2	20
	 True Green	515	1500	120	3.2	20
H19-S328HRKYG	 Red	630	200	120	2.2	20
	 Yellow Green	572	80	120	2.2	20
H19-S328HRLB	 Red	630	350	120	2.2	20
	 Blue	460	380	120	3.2	20

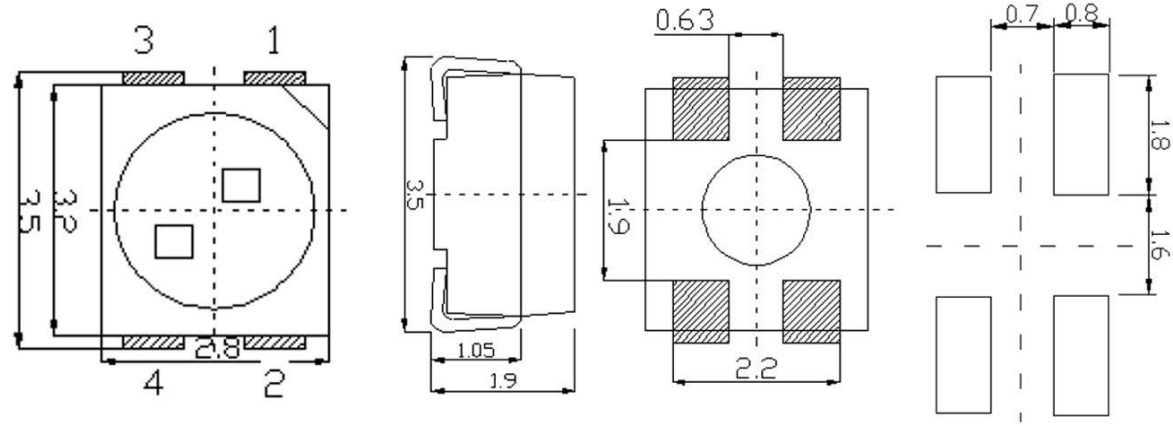

3.5\*2.8\*1.9mm

Part No.	Color	$\lambda_d(\text{nm})$ / CIE(x,y)	Typ. Luminous Intensity $I_v$ (mcd)	View Angle $2\theta_{1/2}$	Typ. Forward Voltage $V_f$ (V)	Forward Current $I_f$ (mA)
H19-328HRSY	<span style="color: red;">■</span> Red	630	213	120	2.2	20
	<span style="color: yellow;">■</span> Yellow	595	210	120	2.2	20
H19-328HRLB	<span style="color: red;">■</span> Red	630	285	120	2.2	20
	<span style="color: blue;">■</span> Blue	461	350	120	3.2	20
H19-328HRTCG	<span style="color: red;">■</span> Red	630	260	120	2.1	20
	<span style="color: green;">■</span> True Green	521	1600	120	3.3	20



1.6\*0.5\*0.8mm

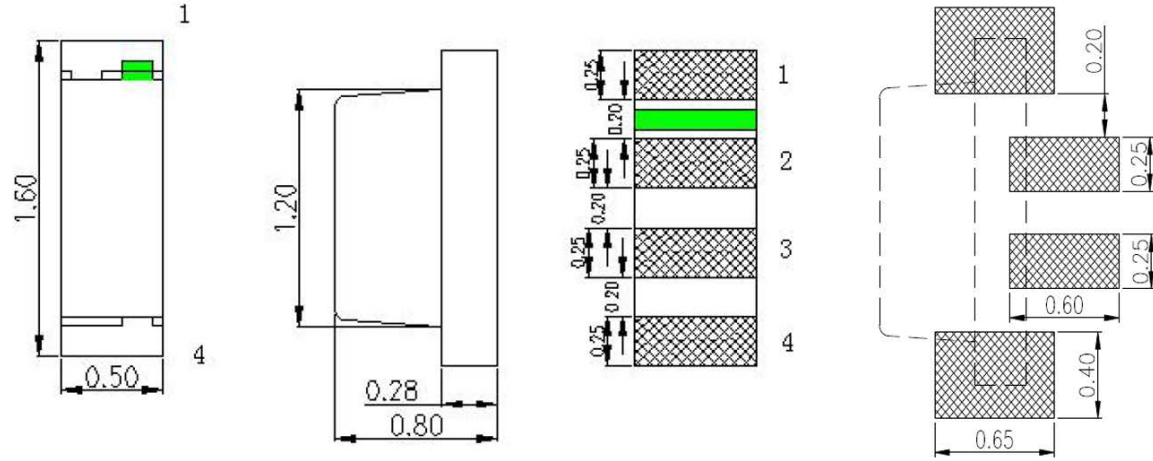

Part No.	Color	$\lambda_d(\text{nm})$ / CIE(x,y)	Typ. Luminous Intensity $I_v$ (mcd)	View Angle $2\theta_{1/2}$	Typ. Forward Voltage $V_F$ (V)	Forward Current $I_F$ (mA)
H5-C108KYGHR/5M	<span style="color: red;">■</span> Red	630	30	120	2.1	5
	<span style="color: yellow;">■</span> Yellow Green	570	12	120	2.1	5
H5-C108B2WHR/5M	<span style="color: red;">■</span> Red	630	35	120	2.1	5
	<span style="color: white;">■</span> White	(0.26, 0.25)	200	120	2.9	5
H5-C108SYTCG/5M	<span style="color: yellow;">■</span> Yellow	592	30	120	2.1	5
	<span style="color: green;">■</span> True Green	515	200	120	2.7	5



2.0\*0.6\*1.1mm

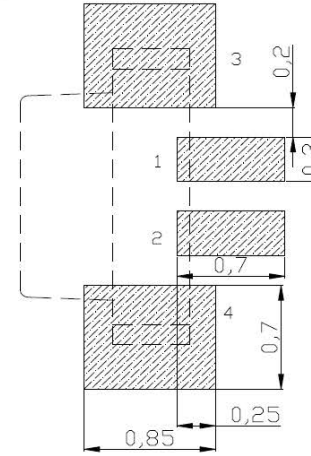
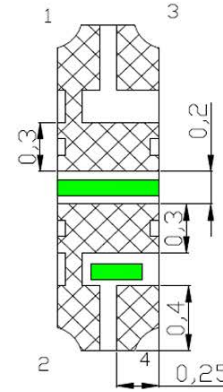
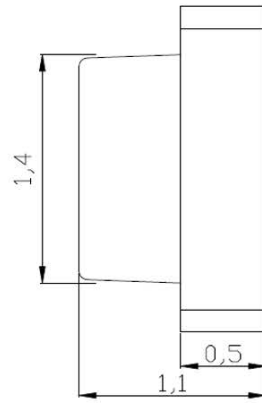
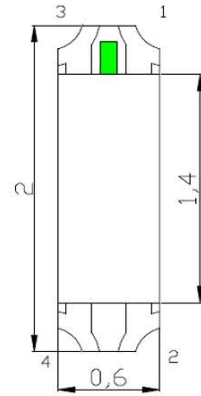

Part No.	Color	$\lambda_d(\text{nm})$ / CIE(x,y)	Typ. Luminous Intensity $I_v$ (mcd)	View Angle $2\theta_{1/2}$	Typ. Forward Voltage $V_f$ (V)	Forward Current $I_f$ (mA)
H6-C211HRKYG	<span style="color: red;">■</span> Red	630	130	120	2.1	20
	<span style="color: yellow;">■</span> Yellow Green	570	40	120	2.1	20
H6-C211HRLB/5M	<span style="color: red;">■</span> Red	630	35	120	2.1	5
	<span style="color: blue;">■</span> Blue	460	30	120	2.8	5
H6-C211LBHR/5M	<span style="color: blue;">■</span> Blue	460	30	120	2.8	5
	<span style="color: red;">■</span> Red	630	35	120	2.1	5



3.2\*1.0\*1.5mm

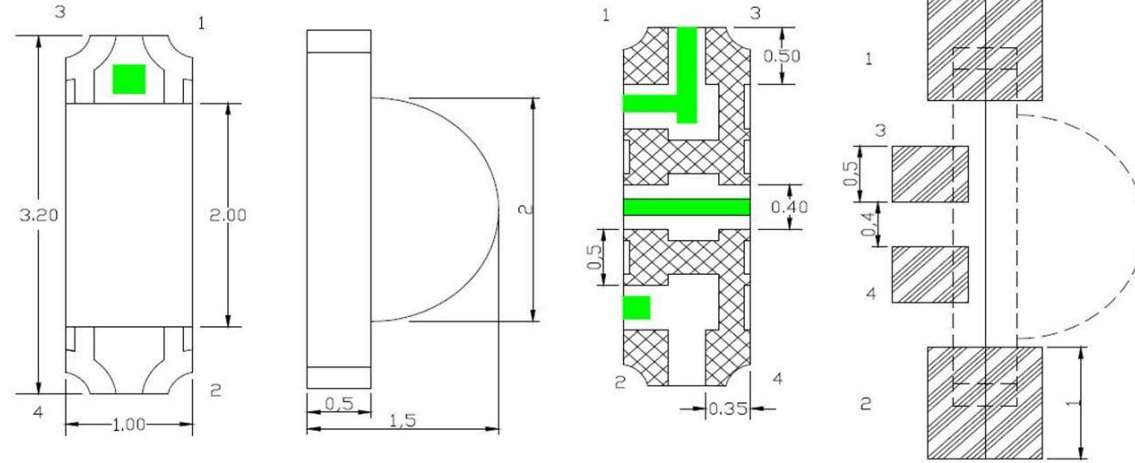

Part No.	Color	$\lambda_d(\text{nm})$ / CIE(x,y)	Typ. Luminous Intensity $I_v$ (mcd)	View Angle $2\theta_{1/2}$	Typ. Forward Voltage $V_F$ (V)	Forward Current $I_F$ (mA)
H10-C315HRKYG	<span style="color: red;">■</span> Red	630	145	120	2.1	20
	<span style="color: yellow;">■</span> Yellow Green	574	40	120	2.1	20



3.2\*1.0\*1.5mm

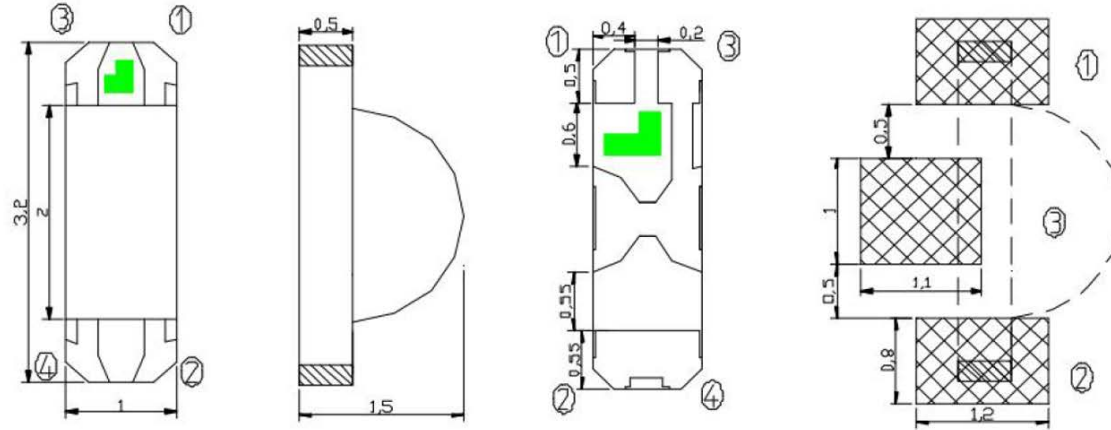

Part No.	Color	$\lambda_d(\text{nm})$ / CIE(x,y)	Typ. Luminous Intensity $I_v$ (mcd)	View Angle $2\theta_{1/2}$	Typ. Forward Voltage $V_F$ (V)	Forward Current $I_F$ (mA)
H10-C315HRKYGYA/5M	<span style="color: red;">■</span> Red	630	40	120	2.1	5
	<span style="color: yellow;">■</span> Yellow Green	570	11.5	120	2.1	5



3.0\*1.0\*2.1mm

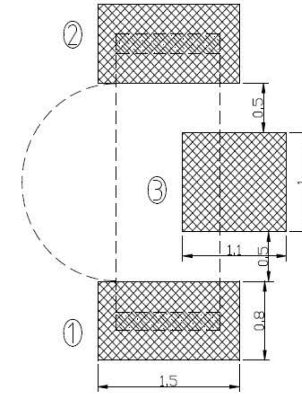
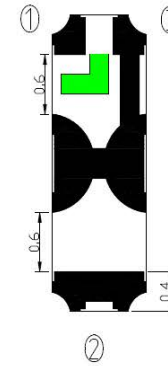
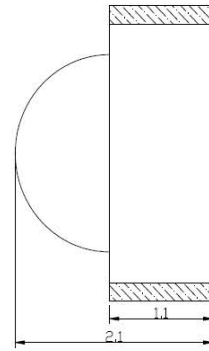
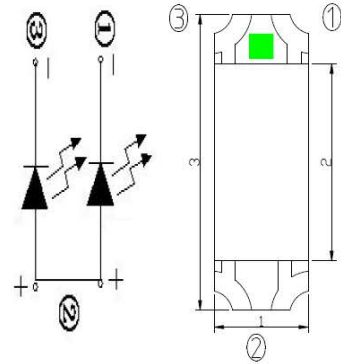

Part No.	Color	$\lambda_d(\text{nm})$ / CIE(x,y)	Typ. Luminous Intensity $I_v$ (mcd)	View Angle $2\theta_{1/2}$	Typ. Forward Voltage $V_f$ (V)	Forward Current $I_f$ (mA)
H10-C321FOKYGYA	Orange	610	115	120	2.2	20
	Yellow Green	575	35	120	2.2	20
H10-C321FOB2WYA/5M	Orange	615	35	120	2.1	5
	White	(0.27, 0.27)	285	120	2.9	5
H10-C321FOKYGYI	Yellow Green	571	35	120	2.2	20
	Yellow	592	115	120	2.2	20



3.0\*1.0\*2.1mm

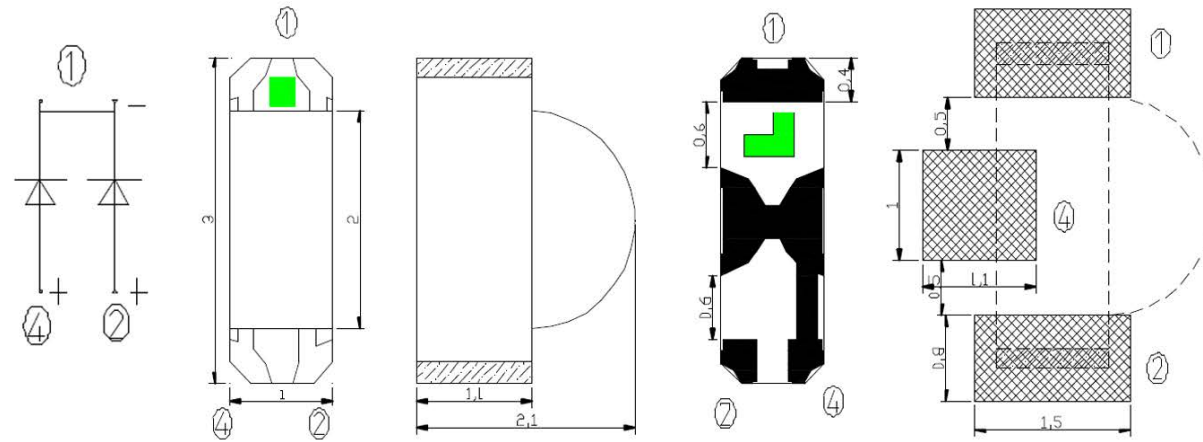

Part No.	Color	$\lambda_d(\text{nm})$ / CIE(x,y)	Typ. Luminous Intensity $I_v$ (mcd)	View Angle $2\theta_{1/2}$	Typ. Forward Voltage $V_F$ (V)	Forward Current $I_F$ (mA)
H10-C321HRKYGYI	<span style="color: red;">■</span> Red	620	120	120	2.1	20
	<span style="color: yellow;">■</span> Yellow Green	576	40	120	2.1	20
H10-C321FOB2WYI/5M	<span style="color: orange;">■</span> Orange	610	35	120	2.1	5
	<span style="color: white;">■</span> White	(0.27, 0.24)	250	120	2.9	5
H10-C321FOKYGYI	<span style="color: orange;">■</span> Orange	610	150	120	2.2	5
	<span style="color: yellow;">■</span> Yellow Green	571	45	120	2.2	5

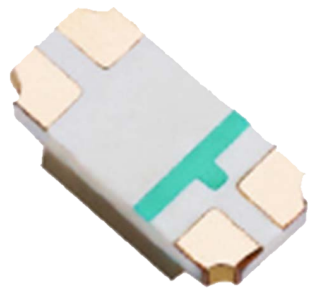

3.2\*1.25\*1.1mm

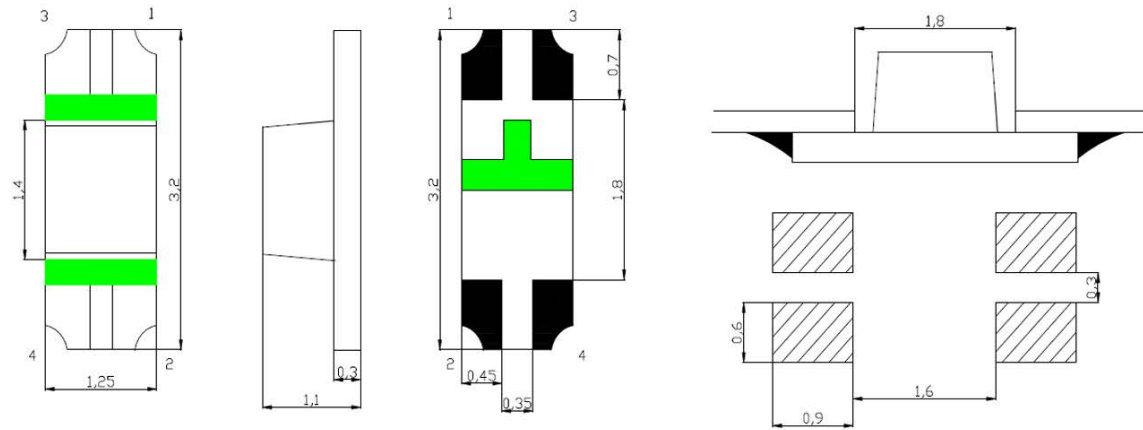

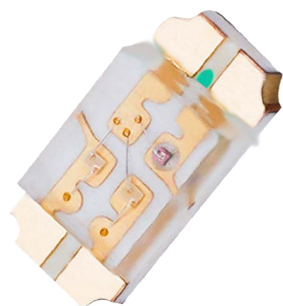

Part No.	Color	$\lambda_d(\text{nm})$ / CIE(x,y)	Typ. Luminous Intensity $I_v$ (mcd)	View Angle $2\theta_{1/2}$	Typ. Forward Voltage $V_f$ (V)	Forward Current $I_f$ (mA)
H11-F312HRKYG/5M	Red	625	35	120	2.1	5
	Yellow Green	574	11.5	120	2.1	5
H11-F312HRLB/5M	Red	630	35	120	2.1	5
	Blue	460	35	120	2.8	5
H11-F312HRTCG/5M	Red	625	35	120	2.1	5
	True Green	524	230	120	2.8	5



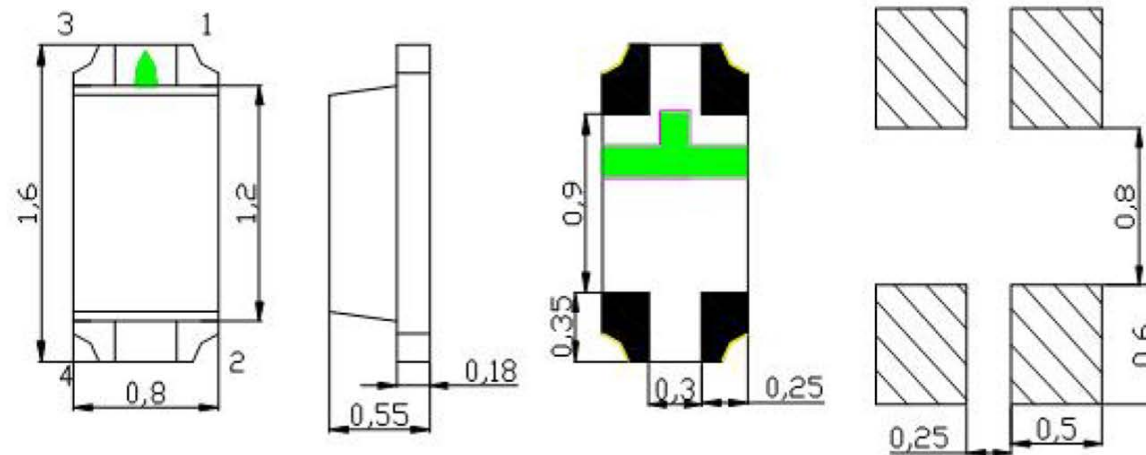

1.6\*0.8\*0.55mm

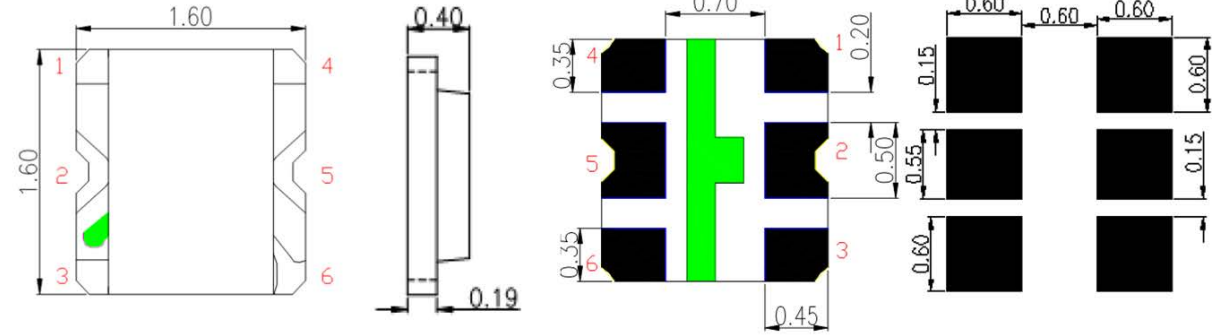

Part No.	Color	$\lambda_d(\text{nm})$ / CIE(x,y)	Typ. Luminous Intensity $I_v$ (mcd)	View Angle $2\theta_{1/2}$	Typ. Forward Voltage $V_f$ (V)	Forward Current $I_f$ (mA)
H6-D108RBGYA/5M	 Red	630	35	120	2.1	5
	 True Green	515	180	120	2.8	5
	 Blue	460	35	120	2.8	5



1.6\*1.6\*0.4mm

Part No.	Color	$\lambda_d(\text{nm})/\text{CIE}(x,y)$	Typ. Luminous Intensity $I_v$ (mcd)	View Angle $2\theta_{1/2}$	Typ. Forward Voltage $V_F$ (V)	Forward Current $I_F$ (mA)
H4-116BRG/5M	 Red	630	45	120	2.1	5
	 True Green	515	285	120	2.8	5
	 Blue	460	45	120	2.8	5

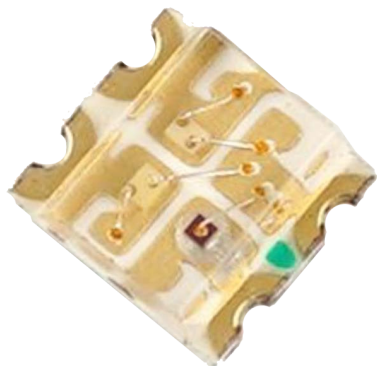

1.6\*1.5\*0.4mm

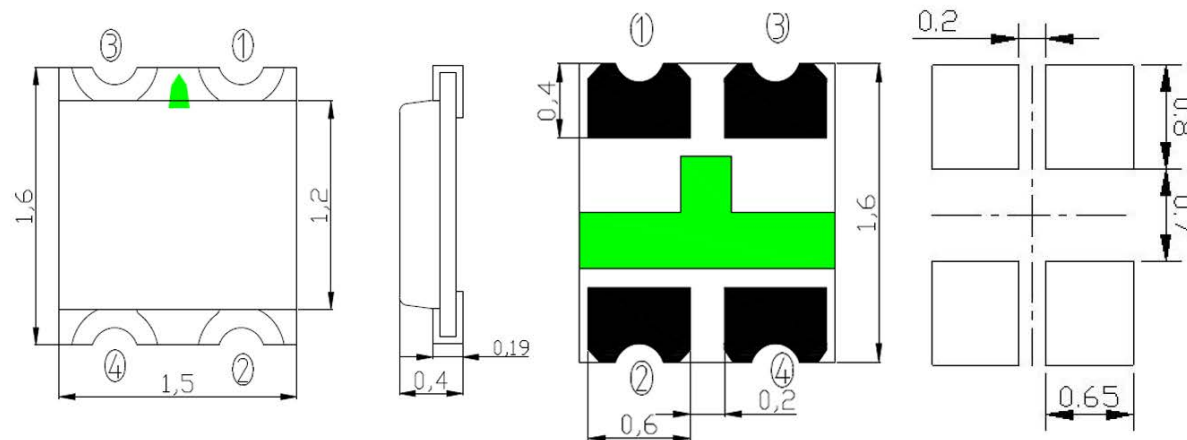

Part No.	Color	$\lambda_d(\text{nm})$ / CIE(x,y)	Typ. Luminous Intensity $I_v$ (mcd)	View Angle $2\theta_{1/2}$	Typ. Forward Voltage $V_F$ (V)	Forward Current $I_F$ (mA)
H4-115BGRYA/5M	<span style="color: red;">■</span> Red	625	45	120	2.1	5
	<span style="color: green;">■</span> True Green	524	285	120	2.8	5
	<span style="color: blue;">■</span> Blue	467	45	120	2.8	5



1.6\*1.5\*0.55mm

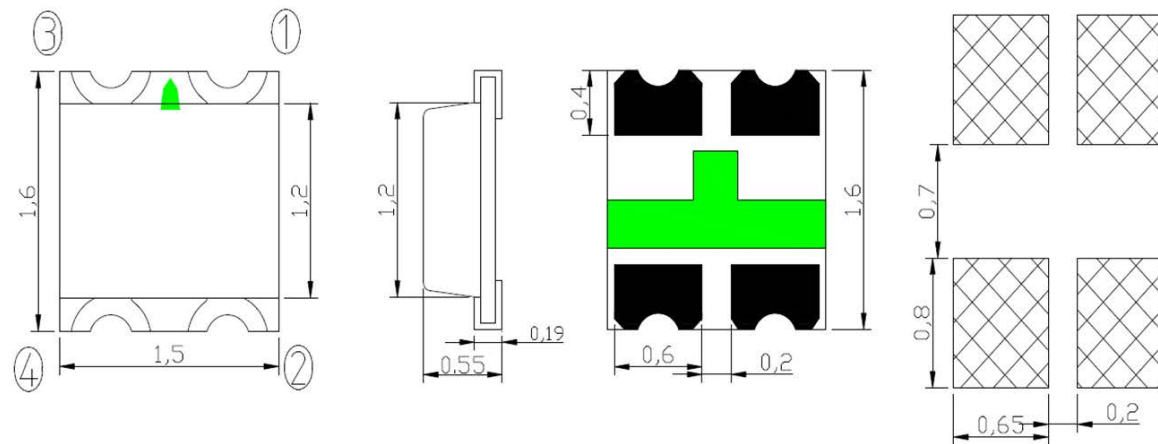



Part No.	Color	$\lambda_d(\text{nm})$ / CIE(x,y)	Typ. Luminous Intensity $I_v$ (mcd)	View Angle $2\theta_{1/2}$	Typ. Forward Voltage $V_f$ (V)	Forward Current $I_f$ (mA)
H6-115BGRYA1	<span style="color: red;">■</span> Red	630	180	120	2.1	20
	<span style="color: green;">■</span> True Green	515	850	120	3.2	20
	<span style="color: blue;">■</span> Blue	460	160	120	3.2	20
H6-115RGBYA1/5M	<span style="color: red;">■</span> Red	630	42	120	2.1	5
	<span style="color: green;">■</span> True Green	515	230	120	2.8	5
	<span style="color: blue;">■</span> Blue	460	42	120	2.8	5

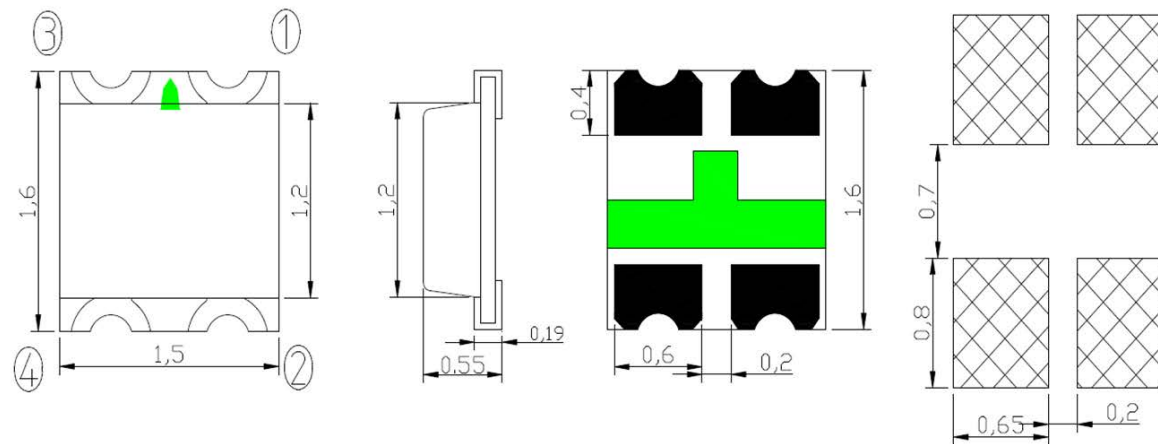

1.6\*1.5\*0.55mm



Part No.	Color	$\lambda_d(\text{nm})$ / CIE(x,y)	Typ. Luminous Intensity $I_v$ (mcd)	View Angle $2\theta_{1/2}$	Typ. Forward Voltage $V_f$ (V)	Forward Current $I_f$ (mA)
H6-115BGARYI	 Red	630	500	120	2.1	20
	 True Green	515	720	120	3.2	20
	 Blue	460	150	120	3.2	20

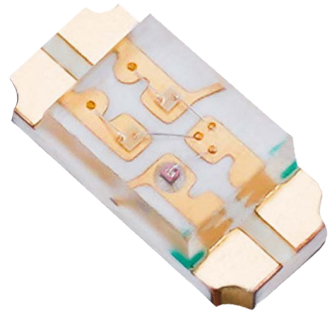



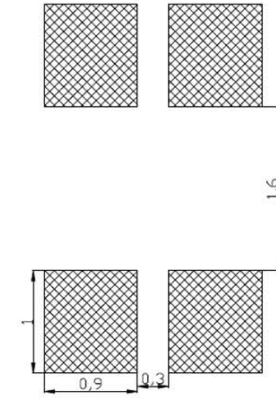
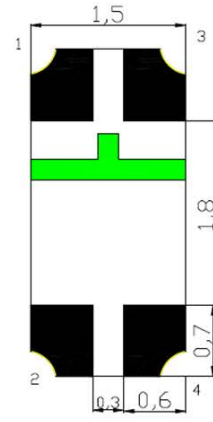
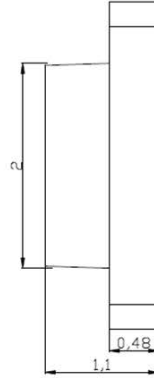
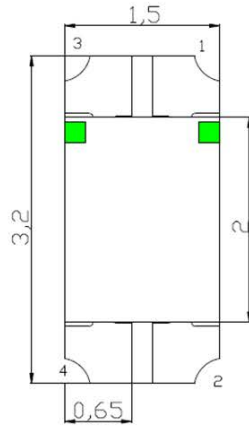

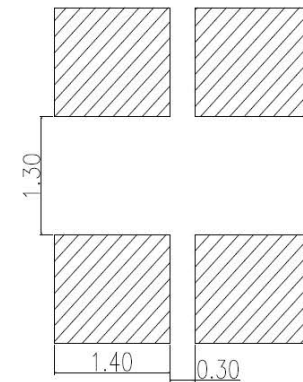
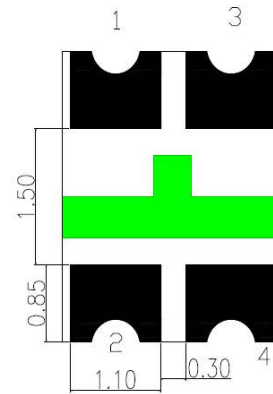
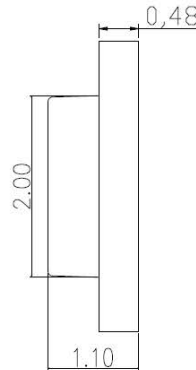
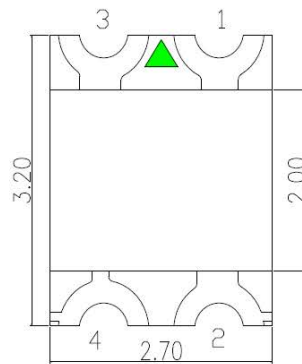

3.2\*1.5\*1.1mm



Part No.	Color	$\lambda_d(\text{nm})$ / CIE(x,y)	Typ. Luminous Intensity $I_v$ (mcd)	View Angle $2\theta_{1/2}$	Typ. Forward Voltage $V_F$ (V)	Forward Current $I_F$ (mA)
H11-D316RGBYA	<span style="color: red;">■</span> Red	630	140	120	2.1	20
	<span style="color: green;">■</span> True Green	515	720	120	3.2	20
	<span style="color: blue;">■</span> Blue	461	150	120	3.2	20



3.2\*2.7\*1.1mm

Part No.	Color	$\lambda_d(\text{nm})$ / CIE(x,y)	Typ. Luminous Intensity $I_v$ (mcd)	View Angle $2\theta_{1/2}$	Typ. Forward Voltage $V_F$ (V)	Forward Current $I_F$ (mA)
H11-327RGBYA	 Red	615	160	120	2.2	20
	 True Green	515	800	120	3.2	20
	 Blue	460	180	120	3.2	20
H11-327RYGYA/5M	 Red	630	45	120	2.1	5
	 True Green	515	260	120	2.8	5
	 Yellow	595	42	120	2.1	5

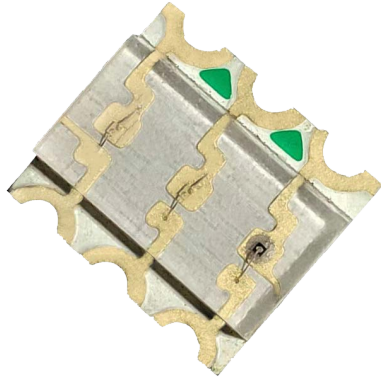

3.2\*3.6\*1.1mm

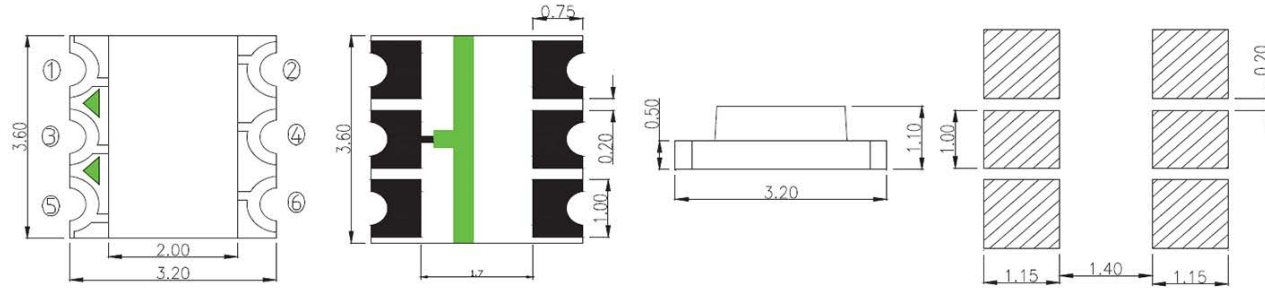

Part No.	Color	$\lambda_d(\text{nm})$ / CIE(x,y)	Typ. Luminous Intensity $I_v$ (mcd)	View Angle $2\theta_{1/2}$	Typ. Forward Voltage $V_f$ (V)	Forward Current $I_f$ (mA)
H11-332RGB	<span style="color: red;">■</span> Red	630	160	120	2.0	20
	<span style="color: green;">■</span> True Green	515	950	120	3.0	20
	<span style="color: blue;">■</span> Blue	460	170	120	3.0	20
H11-332RGB/5M	<span style="color: red;">■</span> Red	630	40	120	2.1	5
	<span style="color: green;">■</span> True Green	515	260	120	2.8	5
	<span style="color: blue;">■</span> Blue	460	45	120	2.8	5



3.5\*2.8\*1.9mm

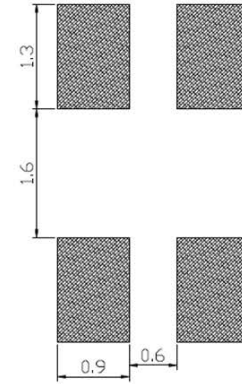
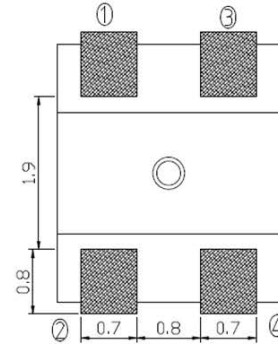
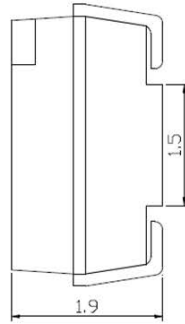
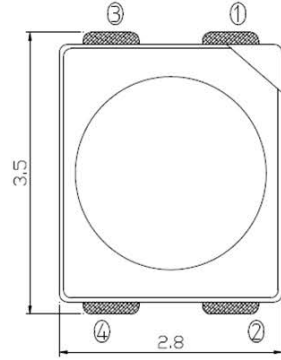

Part No.	Color	$\lambda_d(\text{nm})/$ CIE(x,y)	Typ. Luminous Intensity $I_v$ (mcd)	View Angle $2\theta_{1/2}$	Typ. Forward Voltage $V_F$ (V)	Forward Current $I_F$ (mA)
H19-328RBGYA	Red	620	240	120	2.1	20
	True Green	518	1200	120	3.2	20
	Blue	460	450	120	3.2	20
H19-328RGBYA2	Red	630	280	120	2.1	20
	True Green	516	1200	120	3.2	20
	Blue	459	450	120	3.2	20



3.5\*2.8\*1.9mm

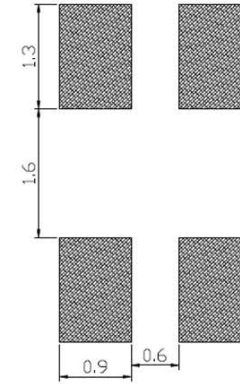
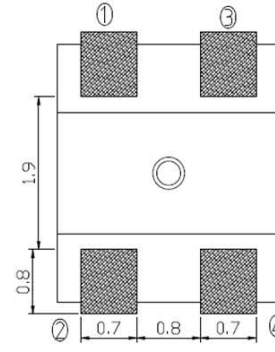
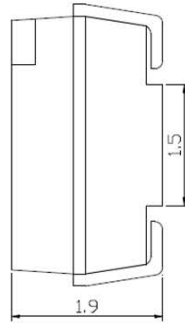
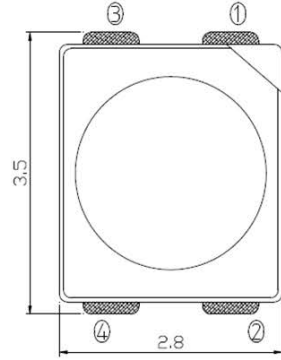

Part No.	Color	$\lambda_d(\text{nm})$ / CIE(x,y)	Typ. Luminous Intensity $I_v$ (mcd)	View Angle $2\theta_{1/2}$	Typ. Forward Voltage $V_F$ (V)	Forward Current $I_F$ (mA)
H19-328BGARYI	<span style="color: red;">■</span> Red	630	750	120	2.2	20
	<span style="color: green;">■</span> True Green	515	1200	120	3.2	20
	<span style="color: blue;">■</span> Blue	460	350	120	3.2	20

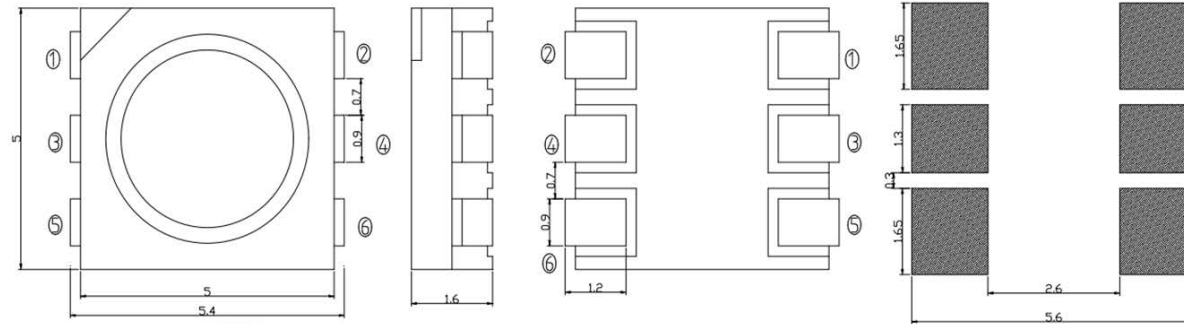

5.0\*5.4\*1.6mm

Part No.	Color	$\lambda_d(\text{nm})/$ CIE(x,y)	Typ. Luminous Intensity $I_v$ (mcd)	View Angle $2\theta_{1/2}$	Typ. Forward Voltage $V_f$ (V)	Forward Current $I_f$ (mA)
H16-550BGAR	Red	630	800	120	2.2	20
	True Green	515	1600	120	3.2	20
	Blue	460	450	120	3.2	20
H16-550QARGB-02W	Red	630	900	120	2.2	20
	True Green	515	1800	120	3.2	20
	Blue	460	700	120	3.2	20

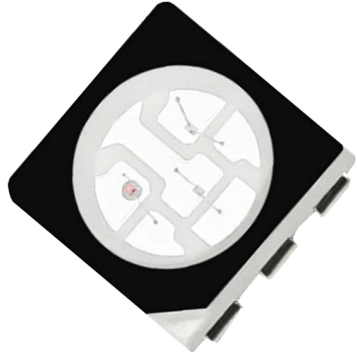

5.0\*5.4\*1.6mm

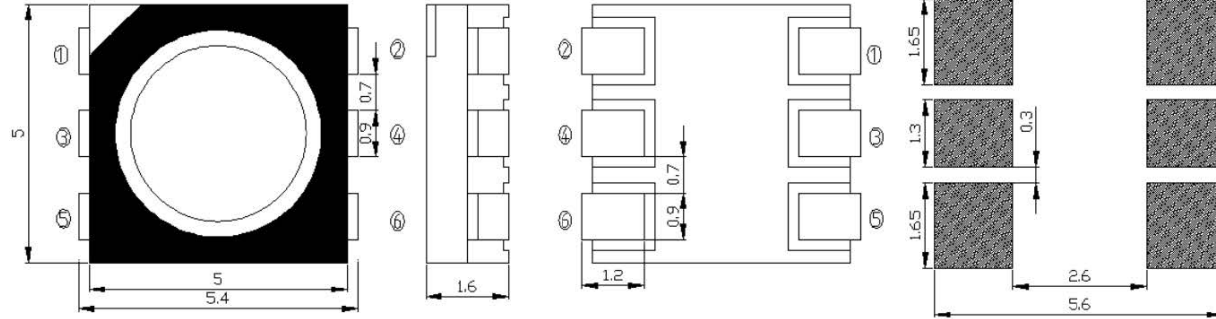

Part No.	Color	$\lambda_d(\text{nm})/\text{CIE}(x,y)$	Typ. Luminous Intensity $I_v$ (mcd)	View Angle $2\theta_{1/2}$	Typ. Forward Voltage $V_f$ (V)	Forward Current $I_f$ (mA)
H16-H550RGBW	<span style="color: red;">■</span> Red	620	800	120	2.2	20
	<span style="color: green;">■</span> True Green	518	1600	120	3.2	20
	<span style="color: blue;">■</span> Blue	460	450	120	3.2	20



1.6\*0.5\*0.8mm

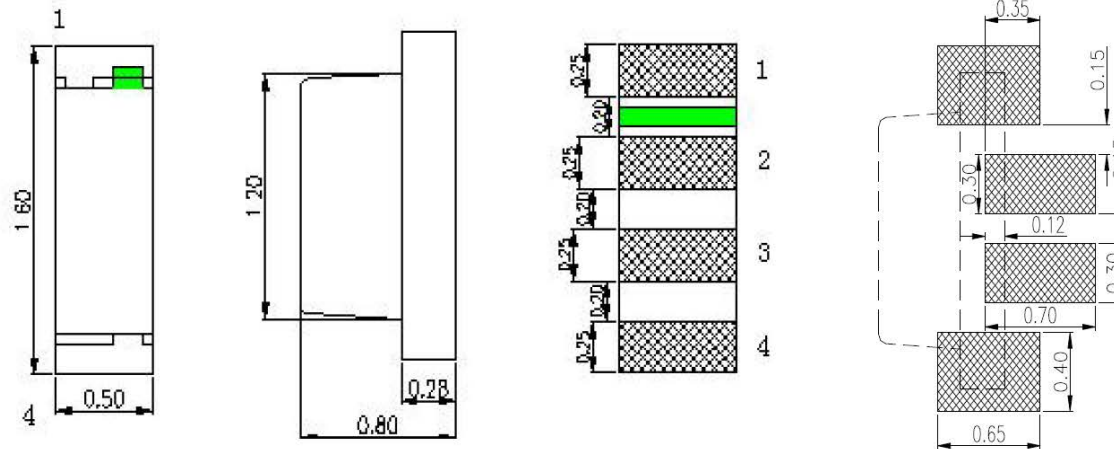

Part No.	Color	$\lambda_d$ (nm)/ CIE(x,y)	Typ. Luminous Intensity $I_v$ (mcd)	View Angle $2\theta_{1/2}$	Typ. Forward Voltage $V_f$ (V)	Forward Current $I_f$ (mA)
H5-C108BRGYA/5M	<span style="color: red;">■</span> Red	630	30	120	2.1	5
	<span style="color: green;">■</span> True Green	518	200	120	2.8	5
	<span style="color: blue;">■</span> Blue	460	30	120	2.8	5



2.0\*0.6\*1.1mm

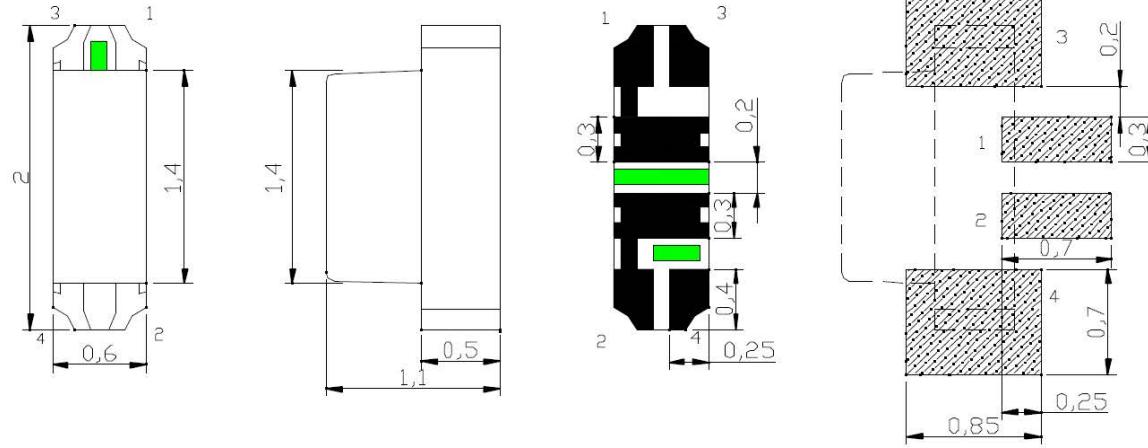





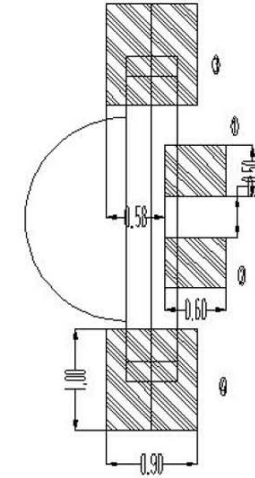
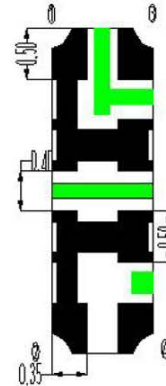
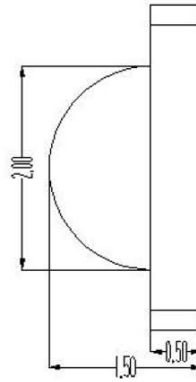
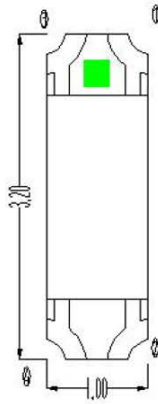

Part No.	Color	$\lambda_d(\text{nm})$ / CIE(x,y)	Typ. Luminous Intensity $I_v$ (mcd)	View Angle $2\theta_{1/2}$	Typ. Forward Voltage $V_f$ (V)	Forward Current $I_f$ (mA)
H6-C211RGBYA3/5M	Red	630	35	120	2.1	5
	True Green	518	200	120	2.8	5
	Blue	460	45	120	2.8	5
H6-C211RGBYA/5M	Red	630	30	120	2.1	5
	True Green	518	200	120	2.8	5
	Blue	460	30	120	2.8	5



3.2\*1.0\*1.5mm







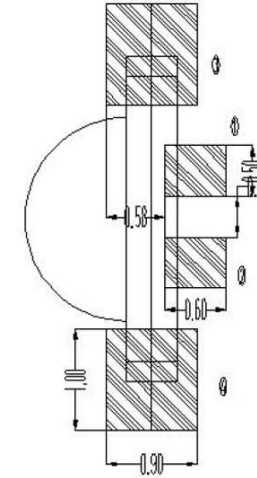
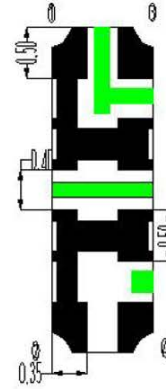
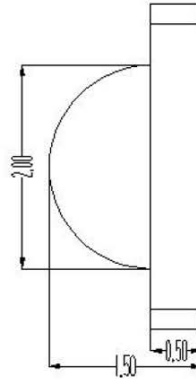
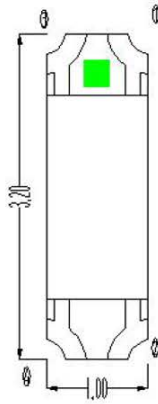

Part No.	Color	$\lambda_d(\text{nm})$ / CIE(x,y)	Typ. Luminous Intensity $I_v$ (mcd)	View Angle $2\theta_{1/2}$	Typ. Forward Voltage $V_F$ (V)	Forward Current $I_F$ (mA)
H10-C315RBGYA3/5M	 Red	630	45	120	2.1	5
	 True Green	515	260	120	2.8	5
	 Blue	460	45	120	2.8	5
H10-C315RGYYA/5M	 Red	630	45	120	2.1	5
	 True Green	515	260	120	2.8	5
	 Yellow	595	45	120	2.1	5



3.2\*1.0\*1.5mm



Part No.	Color	$\lambda_d(\text{nm})$ / CIE(x,y)	Typ. Luminous Intensity $I_v$ (mcd)	View Angle $2\theta_{1/2}$	Typ. Forward Voltage $V_F$ (V)	Forward Current $I_F$ (mA)
H10-C315ARBGYI/5M	 Red	630	100	120	2.1	5
	 True Green	518	280	120	2.8	5
	 Blue	461	40	120	2.8	5
H10-C315ARGBYI	 Red	630	500	120	2.1	20
	 True Green	518	1000	120	3.2	20
	 Blue	461	230	120	3.2	20

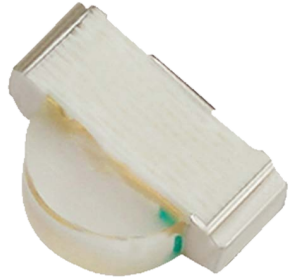

3.0\*1.0\*2.1mm

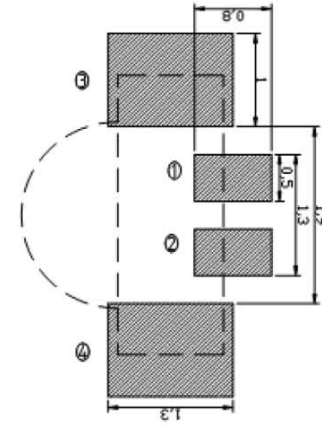
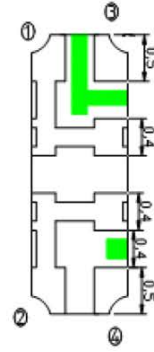
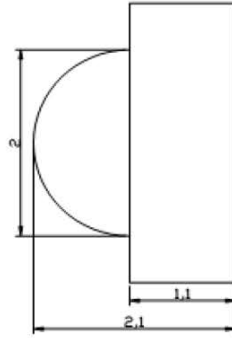
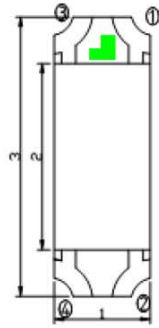

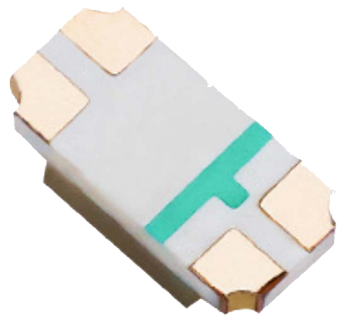

Part No.	Color	$\lambda_d(\text{nm})$ / CIE(x,y)	Typ. Luminous Intensity $I_v$ (mcd)	View Angle $2\theta_{1/2}$	Typ. Forward Voltage $V_F$ (V)	Forward Current $I_F$ (mA)
H10-C321RGBYA/5M	<span style="color: red;">■</span> Red	630	35	120	2.1	5
	<span style="color: green;">■</span> True Green	515	200	120	2.9	5
	<span style="color: blue;">■</span> Blue	461	45	120	2.9	5

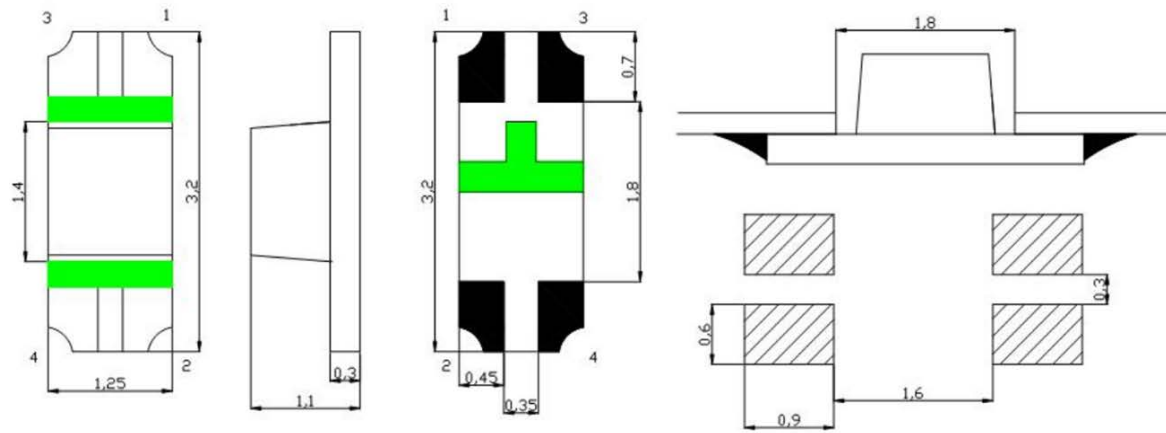

3.2\*1.25\*1.1mm



Part No.	Color	$\lambda_d(\text{nm})$ / CIE(x,y)	Typ. Luminous Intensity $I_v$ (mcd)	View Angle $2\theta_{1/2}$	Typ. Forward Voltage $V_F$ (V)	Forward Current $I_F$ (mA)
H11-F312RGBYA/5M	 Red	630	35	120	2.0	5
	 True Green	515	200	120	2.8	5
	 Blue	461	35	120	2.8	5

