

Green-Mode PWM Controller with Integrated Protections

Rev. 01c

General Description

The LD7535/LD7535A are low cost, low startup current, current mode PWM controllers with green-mode power-saving operation. The integrated functions include the leading-edge blanking of the current sensing, internal slope compensation and the tiny package of SOT-26. They provide the users a superior AC/DC power application of higher efficiency, low external component counts, and lower cost solution.

Furthermore, LD7535/LD7535A features more protections like OLP (Over Load Protection) and OVP (Over Voltage Protection) to eliminate the external protection circuits. And to satisfy different designs, 2 versions of OVP levels are implemented as ---

- LD7535 --- $28.0V \pm 1.5V$.
- LD7535A --- $21.0V \pm 1.5V$.

Features

- High-Voltage CMOS Process with Excellent ESD protection
- Very Low Startup Current ($<20\mu A$)
- Current Mode Control
- Non-audible-noise Green Mode Control
- UVLO (Under Voltage Lockout)
- LEB (Leading-Edge Blanking) on CS Pin
- Programmable Switching Frequency
- Internal Slope Compensation
- OVP (Over Voltage Protection) on Vcc Pin
- OLP (Over Load Protection)
- 300mA Driving Capability

Applications

- Switching AC/DC Adaptor and Battery Charger
- Open Frame Switching Power Supply
- 384X Replacement

Typical Application

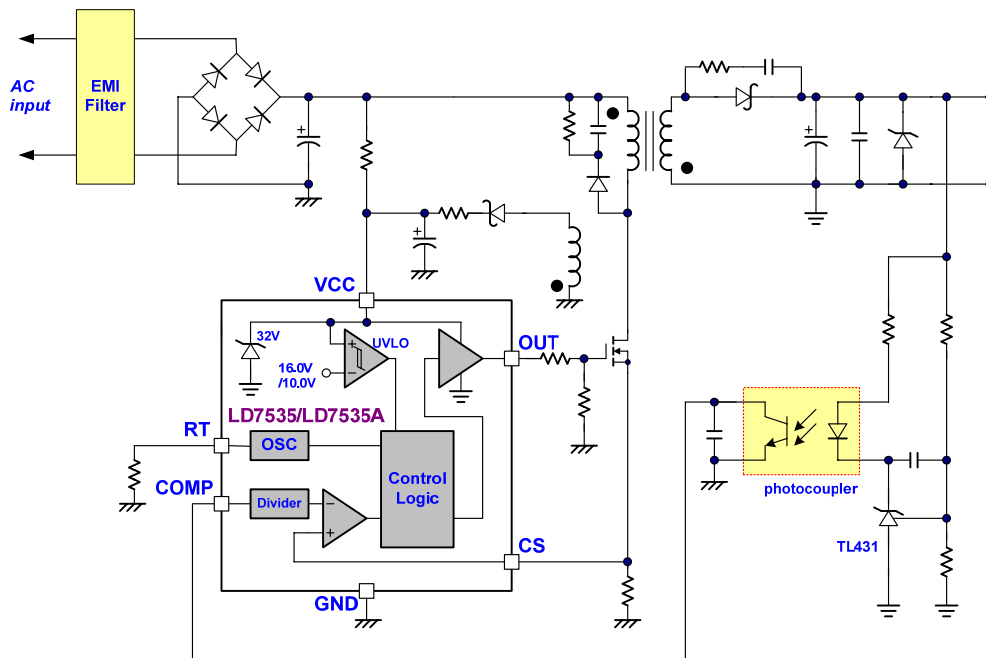

Pin Configuration (LD7535)

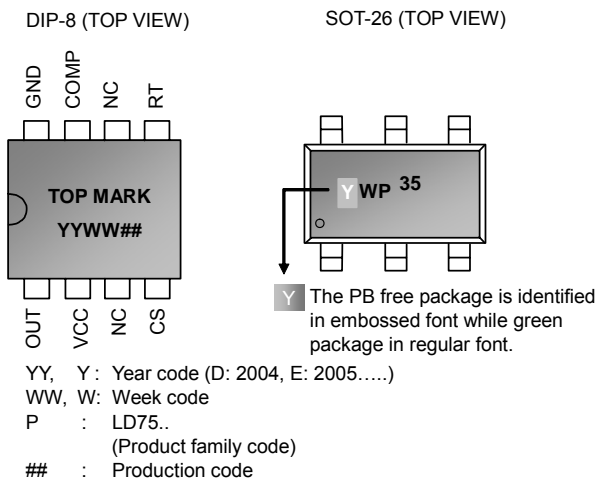

Pin Configuration (LD7535A)

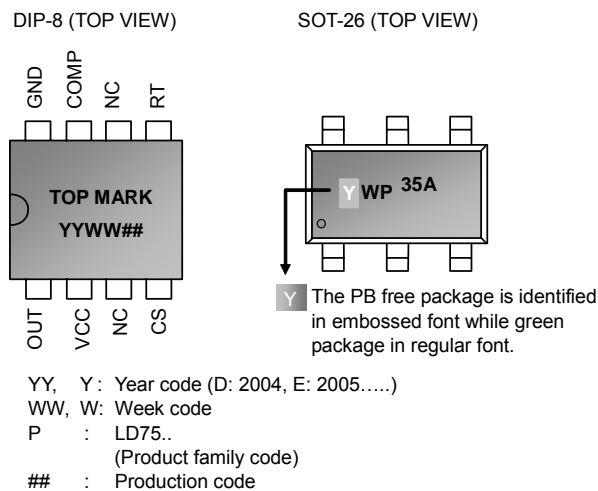

Ordering Information

Part number	Package		TOP MARK	Shipping
LD7535 BL	SOT-26	PB Free	YWP/35	3000 /tape & reel
LD7535 GL	SOT-26	Green Package	YWP/35	3000 /tape & reel
LD7535 BN	DIP-8	PB Free	LD7535BN	3600 /tube /Carton
LD7535A BL	SOT-26	PB Free	YWP/35A	3000 /tape & reel
LD7535A GL	SOT-26	Green Package	YWP/35A	3000 /tape & reel
LD7535A BN	DIP-8	PB Free	LD7535ABN	3600 /tube /Carton

The LD7535/ LD7535A are ROHS Complaint/ Green Package.

Pin Descriptions

PIN	NAME	FUNCTION
1	GND	Ground
2	COMP	Voltage feedback pin (same as the COMP pin in UC384X), By connecting a photo-coupler to close the control loop and achieve the regulation.
3	RT	This pin is to program the switching frequency. By connecting a resistor to ground to set the switching frequency.
4	CS	Current sense pin, connect to sense the MOSFET current
5	VCC	Supply voltage pin
6	OUT	Gate drive output to drive the external MOSFET

Absolute Maximum Ratings

Supply Voltage VCC.....	30V
COMP, RT, CS.....	-0.3 ~7V
Junction Temperature.....	150°C
Operating Ambient Temperature.....	-40°C to 85°C
Storage Temperature Range.....	-65°C to 150°C
Package Thermal Resistance (SOT-26).....	250°C/W
Package Thermal Resistance (DIP-8).....	100°C/W
Power Dissipation (SOT-26, at Ambient Temperature = 85°C).....	250mW
Power Dissipation (DIP-8, at Ambient Temperature = 85°C).....	650mW
Lead temperature (Soldering, 10sec).....	260°C
ESD Voltage Protection, Human Body Model.....	3KV
ESD Voltage Protection, Machine Model.....	250V
Gate Output Current.....	300mA

Caution:

Stresses beyond the ratings specified in "Absolute Maximum Ratings" may cause permanent damage to the device. This is a stress only rating and operation of the device at these or any other conditions above those indicated in the operational sections of this specification is not implied.

Recommended Operating Conditions

Item	Min.	Max.	Unit
Supply Voltage Vcc (LD7535)	11	25	V
Supply Voltage Vcc (LD7535A)	11	18	V
Switching Frequency	50	130	KHz
Startup Resistor Value	1.2	4.4	MΩ

Electrical Characteristics

($T_A = +25^\circ\text{C}$ unless otherwise stated, $V_{CC}=15.0\text{V}$)

PARAMETER	CONDITIONS	MIN	TYP	MAX	UNITS
Supply Voltage (Vcc Pin)					
Startup Current			8	20	μA
Operating Current (with 1nF load on OUT pin)	$V_{\text{COMP}}=0\text{V}$		2.0	3.0	mA
	$V_{\text{COMP}}=3\text{V}$		2.5		mA
	Protection tripped (OLP, OVP)		0.5		mA
UVLO (off)		9.0	10.0	11.0	V
UVLO (on)		15.0	16.0	17.0	V
OVP Level	LD7535	26.5	28.0	29.5	V
	LD7535A	19.5	21.0	22.5	V
Voltage Feedback (Comp Pin)					
Short Circuit Current	$V_{\text{COMP}}=0\text{V}$		1.5	2.2	mA
Open Loop Voltage	COMP pin open		6.0		V
Green Mode Threshold VCOMP			2.35		V
Current Sensing (CS Pin)					
Maximum Input Voltage, $V_{\text{cs}}(\text{off})$		0.80	0.85	0.90	V
Leading Edge Blanking Time			350		nS
Input impedance		1			$\text{M}\Omega$
Delay to Output			100		nS
Oscillator (RT pin)					
Frequency	$R_T=100\text{K}\Omega$	60	65	70	KHz
Green Mode Frequency	$F_s=65\text{KHz}$		20		KHz
Temp. Stability	$(-40^\circ\text{C} \sim 105^\circ\text{C})$			3	%
Voltage Stability	$(V_{CC}=11\text{V}-25\text{V})$			1	%
Gate Drive Output (OUT Pin)					
Output Low Level	$V_{CC}=15\text{V}, I_o=20\text{mA}$			1	V
Output High Level	$V_{CC}=15\text{V}, I_o=20\text{mA}$	8			V
Rising Time	Load Capacitance=1000pF		50	200	nS
Falling Time	Load Capacitance=1000pF		30	100	nS
OLP (Over Load Protection)					
OLP Trip Level	$V_{\text{COMP}}(\text{OLP})$		5.0		V
OLP Delay Time (note)	$F_s=65\text{KHz}$		60		mS

Note: The OLP delay time is proportional to the period of switching cycle. So that, the lower R_T value will set the higher switching frequency and the shorter OLP delay time.

Typical Performance Characteristics

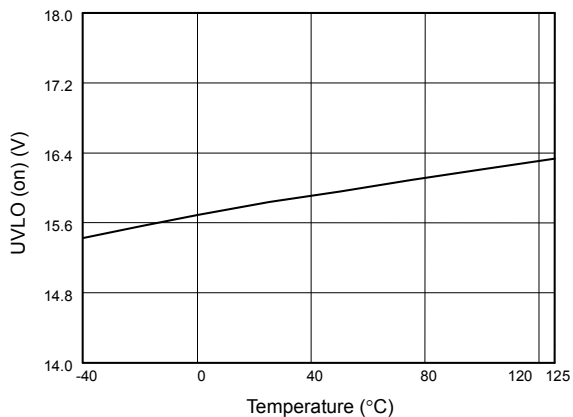

Fig. 1 UVLO (on) vs. Temperature

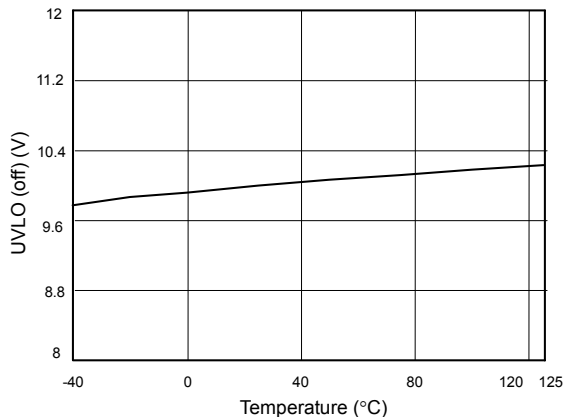

Fig. 2 UVLO (off) vs. Temperature

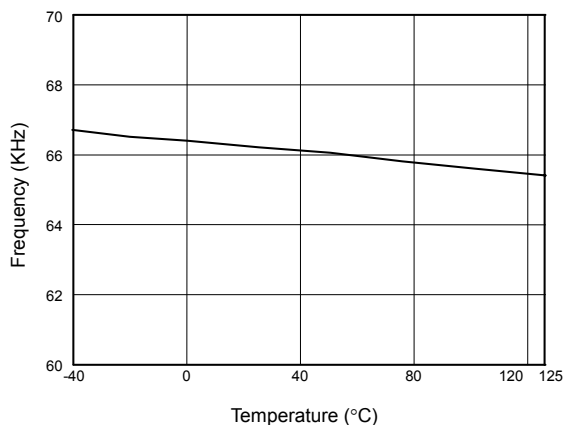

Fig. 3 Frequency vs. Temperature

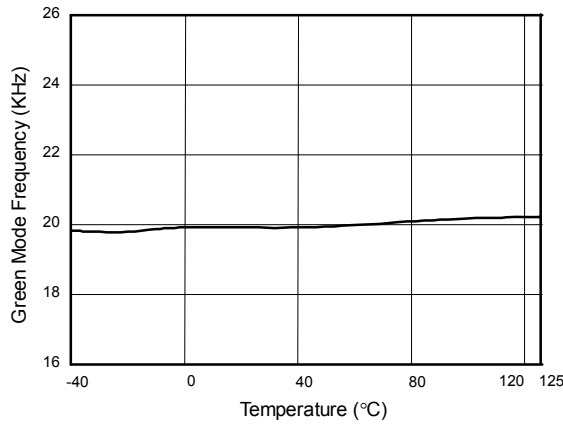

Fig. 4 Green Mode Frequency vs. Temperature

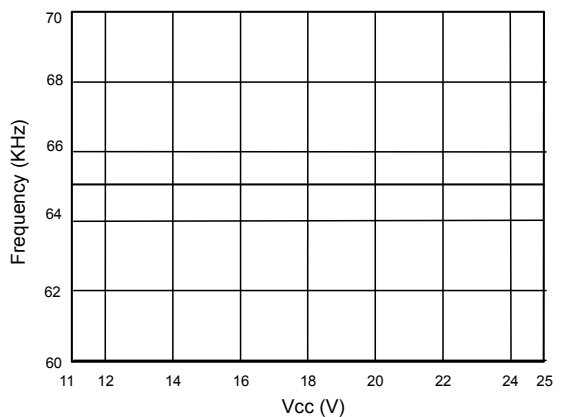

Fig. 5 Frequency vs. Vcc

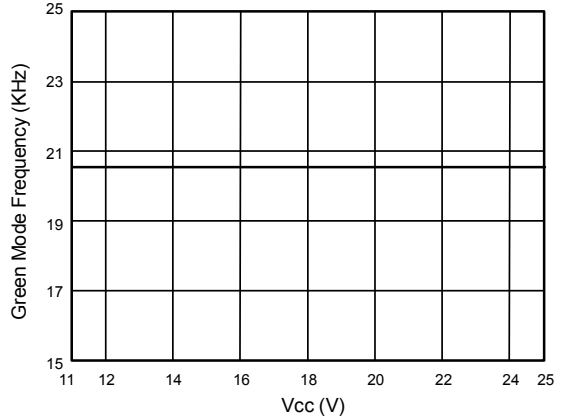

Fig. 6 Green Mode Frequency vs. Vcc

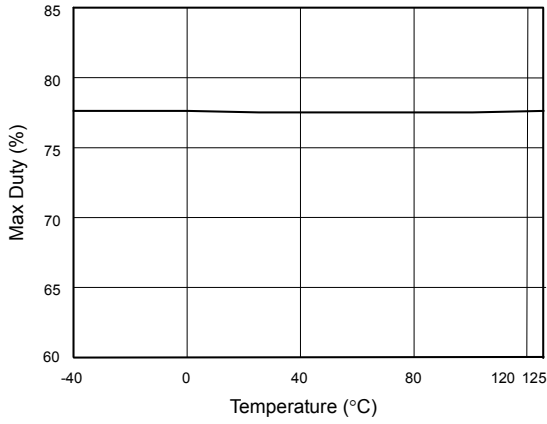

Fig. 7 Max Duty vs. Temperature

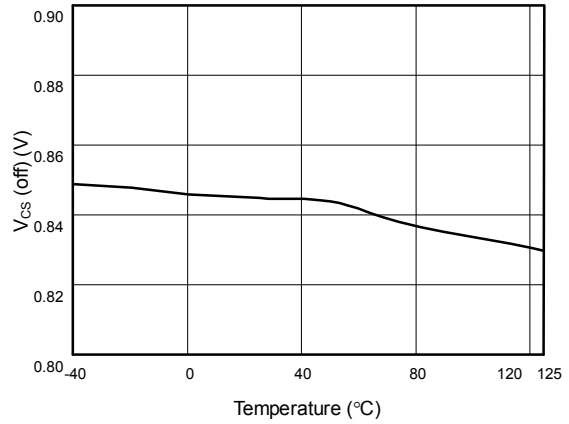

Fig. 8 V_{CS} (off) vs. Temperature

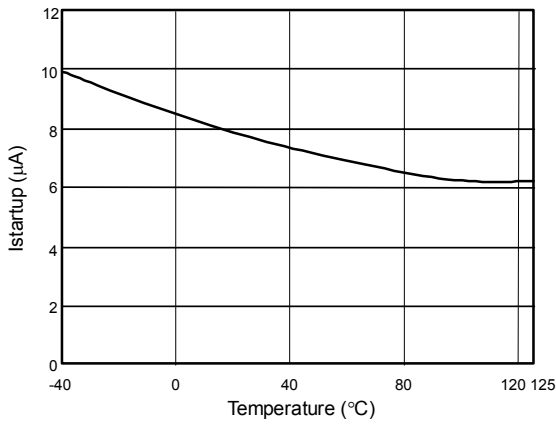

Fig. 9 Startup Current (I_{startup}) vs. Temperature

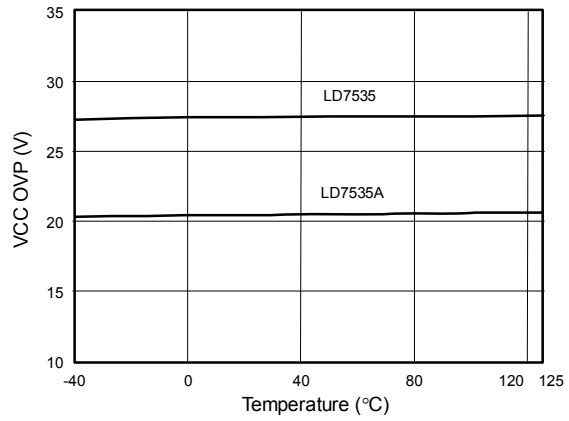

Fig. 10 VCC OVP vs. Temperature

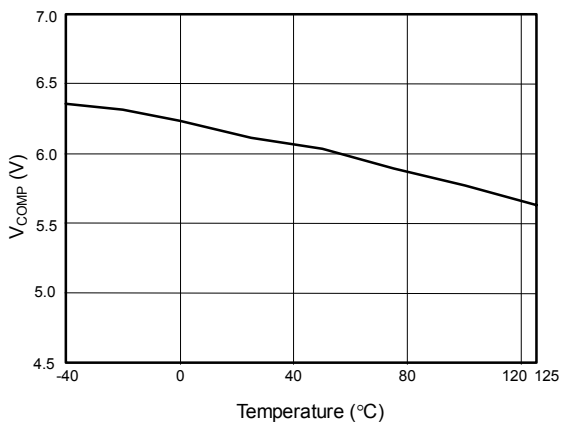

Fig. 11 V_{COMP} open loop voltage vs. Temperature

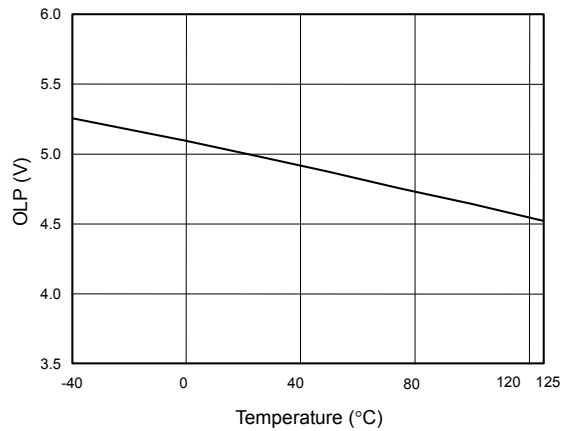

Fig. 12 OLP-Trip Level vs. Temperature

Application Information

Operation Overview

The LD7535/LD7535A meet the green-power requirement and are intended for the use in those modern switching power suppliers and adaptors which demand higher power efficiency and power-saving. They integrated more functions to reduce the external component counts and the size. Their major features are described as below.

Under Voltage Lockout (UVLO)

An UVLO comparator is implemented in it to detect the voltage on the VCC pin. It would assure the supply voltage enough to turn on the LD7535/LD7535A PWM controller and further to drive the power MOSFET. As shown in Fig. 13, a hysteresis is built in to prevent the shutdown from the voltage dip during startup. The turn-on and turn-off threshold level are set at 16.0V and 10.0V, respectively.

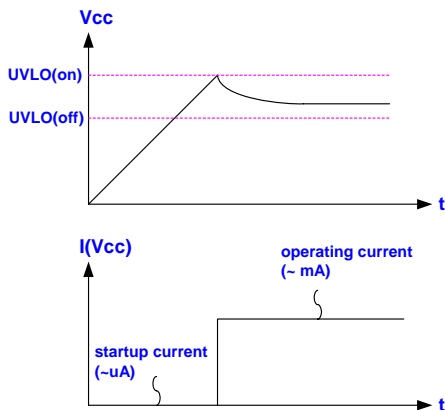

Fig. 13

Startup Current and Startup Circuit

The typical startup circuit to generate the LD7535/LD7535A Vcc is shown in Fig. 14. During the startup transient, the Vcc is lower than the UVLO threshold thus there is no gate pulse produced from LD7535/LD7535A to drive power MOSFET. Therefore, the current through R1 will provide the startup current and to charge the capacitor C1. Whenever the Vcc voltage is high enough to turn on the LD7535/LD7535A and further to deliver the gate drive signal, the supply current is provided from the auxiliary winding of the transformer. Lower startup current requirement on the

PWM controller will help to increase the value of R1 and then reduce the power consumption on R1. By using CMOS process and the special circuit design, the maximum startup current of LD7535/LD7535A is only 20μA.

If a higher resistance value of the R1 is chosen, it usually takes more time to start up. To carefully select the value of R1 and C1 will optimize the power consumption and startup time.

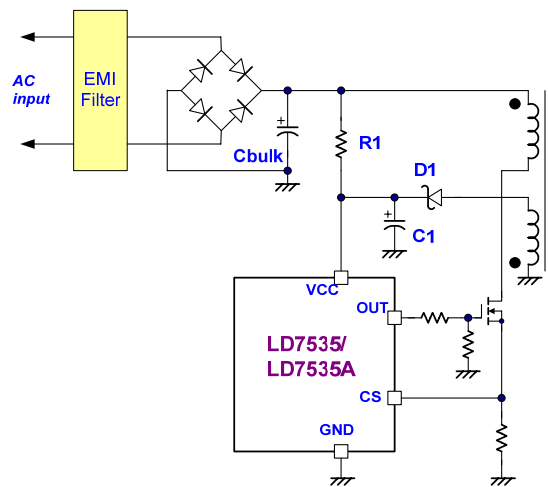

Fig. 14

Current Sensing and Leading-edge Blanking

The typical current mode of PWM controller feedbacks both current signal and voltage signal to close the control loop and achieve regulation. As shown in Fig. 15, the LD7535/LD7535A detect the primary MOSFET current from the CS pin, which is not only for the peak current mode control but also for the pulse-by-pulse current limit. The maximum voltage threshold of the current sensing pin is set at 0.85V. From above, the MOSFET peak current can be obtained from below.

$$I_{PEAK(MAX)} = \frac{0.85V}{R_S}$$

LD7535/LD7535A

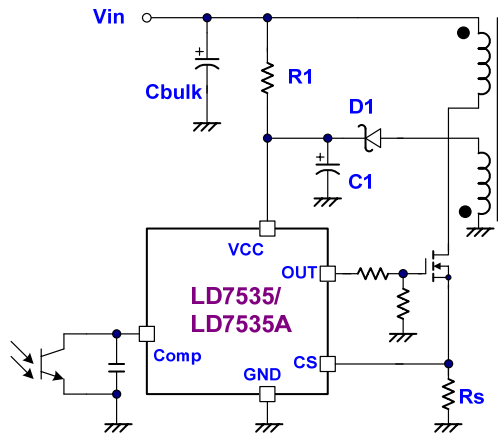

Fig. 15

A 350nS leading-edge blanking (LEB) time is included in the input of CS pin to prevent the false-trigger from the current spike. In the low power application, if the total pulse width of the turn-on spikes is less than 350nS and the negative spike on the CS pin doesn't exceed -0.3V, it could eliminated the R-C filter (as shown in the figure16).

However, the total pulse width of the turn-on spike is decided by the output power, circuit design and PCB layout. It is strongly recommended to adopt a smaller R-C filter (as shown in figure 17) for higher power application to avoid the CS pin being damaged by the negative turn-on spike.

Output Stage and Maximum Duty-Cycle

An output stage of a CMOS buffer, with typical 300mA driving capability, is incorporated to drive a power MOSFET directly. And the maximum duty-cycle of LD7535/LD7535A is limited to 75% to avoid the transformer saturation.

Oscillator and Switching Frequency

Connect a resistor from RT pin to GND according to the equation below to program the normal switching frequency:

$$f_{SW} = \frac{65.0}{RT(K\Omega)} \times 100(KHz)$$

The operating frequency range for the LD7535/LD7535A is recommended to set between 50KHz and 130KHz.

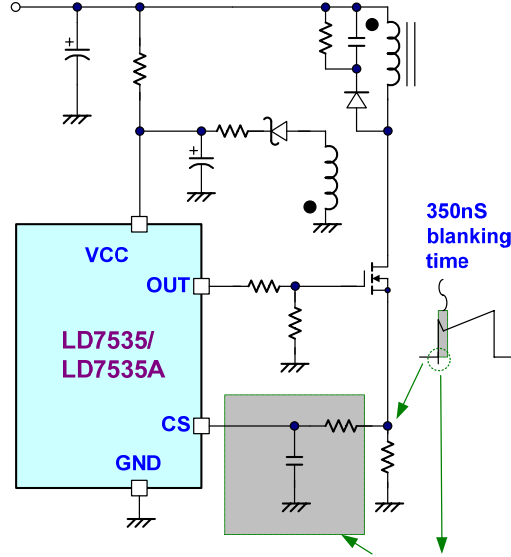

Fig. 16

Can be removed if the negative spike is not over spec. (-0.3V).

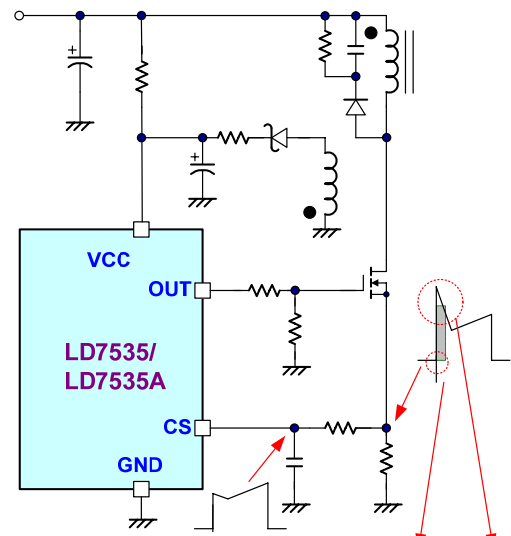

Fig. 17

R-C filter is needed whenever the negative spike is exceed -0.3V or the total spike width is over 350nS LEB period.

Voltage Feedback Loop

The voltage feedback signal is provided from the TL431 at the secondary side through the photo-coupler to the COMP pin of the LD7535/LD7535A. Similar to UC3842, the LD7535/LD7535A would carry 2 diodes voltage offset at the stage to feed the voltage divider at the ratio of 1/3, that is,

$$V_{-(PWM_{COMPARATOR})} = \frac{1}{3} \times (V_{COMP} - 2V_F)$$

A pull-high resistor is embedded internally and can be eliminated externally.

Internal Slope Compensation

In the conventional application, the problem of the stability is a critical issue for current mode controlling, when it operates in higher than 50% of the duty-cycle. As UC384X, It takes slope compensation from injecting the ramp signal of the RT/CT pin through a coupling capacitor. It therefore requires no extra design for the LD7535/LD7535A since it has integrated it already.

On/Off Control

The LD7535/LD7535A can be turned off by pulling COMP pin lower than 1.2V. The gate output pin of the LD7535/LD7535A will be disabled immediately under such condition. The off-mode can be released when the pull-low signal is removed.

Dual-Oscillator Green-Mode Operation

There are many different topologies has been implemented in different chips for the green-mode or power saving requirements such as "burst-mode control", "skipping-cycle mode", "variable off-time control"...etc. The basic operation theory of all these approaches intended to reduce the switching cycles under light-load or no-load condition either by skipping some switching pulses or reduce the switching frequency.

By using this dual-oscillator control, the green-mode frequency can be well controlled and further to avoid the generation of audible noise.

OVP (Over Voltage Protection) on Vcc

The V_{GS} ratings of the nowadays power MOSFETs are often limited up to max. 30V. To prevent the V_{GS} from the fault condition, LD7535/LD7535A are implemented an OVP function on Vcc. Whenever the Vcc voltage is higher than the OVP threshold voltage, the output gate drive circuit will be shutdown simultaneously thus to stop the switching of the power MOSFET until the next UVLO(on).

The Vcc OVP function in LD7535/LD7535A is an auto-recovery type protection. If the OVP condition, usually caused by the feedback loop opened, is not released, the Vcc will tripped the OVP level again and re-shutdown the output. The Vcc is working as a hiccup mode. The Figure. 18 shows its operation.

On the other hand, if the OVP condition is removed, the Vcc level will get back to normal level and the output will automatically return to the normal operation.

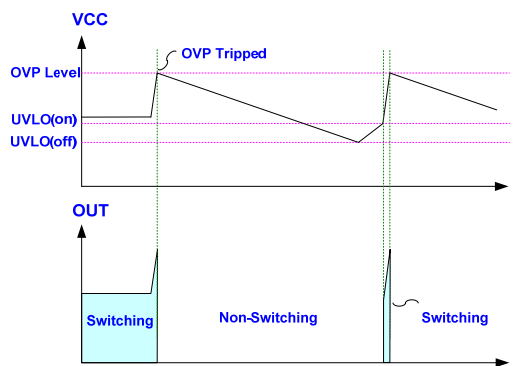

Fig. 18

The OVP levels are ---

- LD7535 --- 28.0V ± 1.5V.
- LD7535A --- 21.0V ± 1.5V.

Over Load Protection (OLP)

To protect the circuit from being damaged under over load condition or short condition, a smart OLP function is implemented in the LD7535/LD7535A. The figure 20 shows the waveforms of the OLP operation. In this case, the feedback system will force the voltage loop proceed toward the saturation and then pull up the voltage on COMP pin (V_{COMP}). Whenever the V_{COMP} trips up to the OLP threshold 5V and stays longer than 60mS, the protection will activate and then turn off the gate output to stop the switching of power circuit. The 60mS delay time is to prevent the false trigger from the power-on and turn-off transient.

By such protection mechanism, the average input power can be reduced to very low level so that the component temperature and stress can be controlled within the safe operating area.

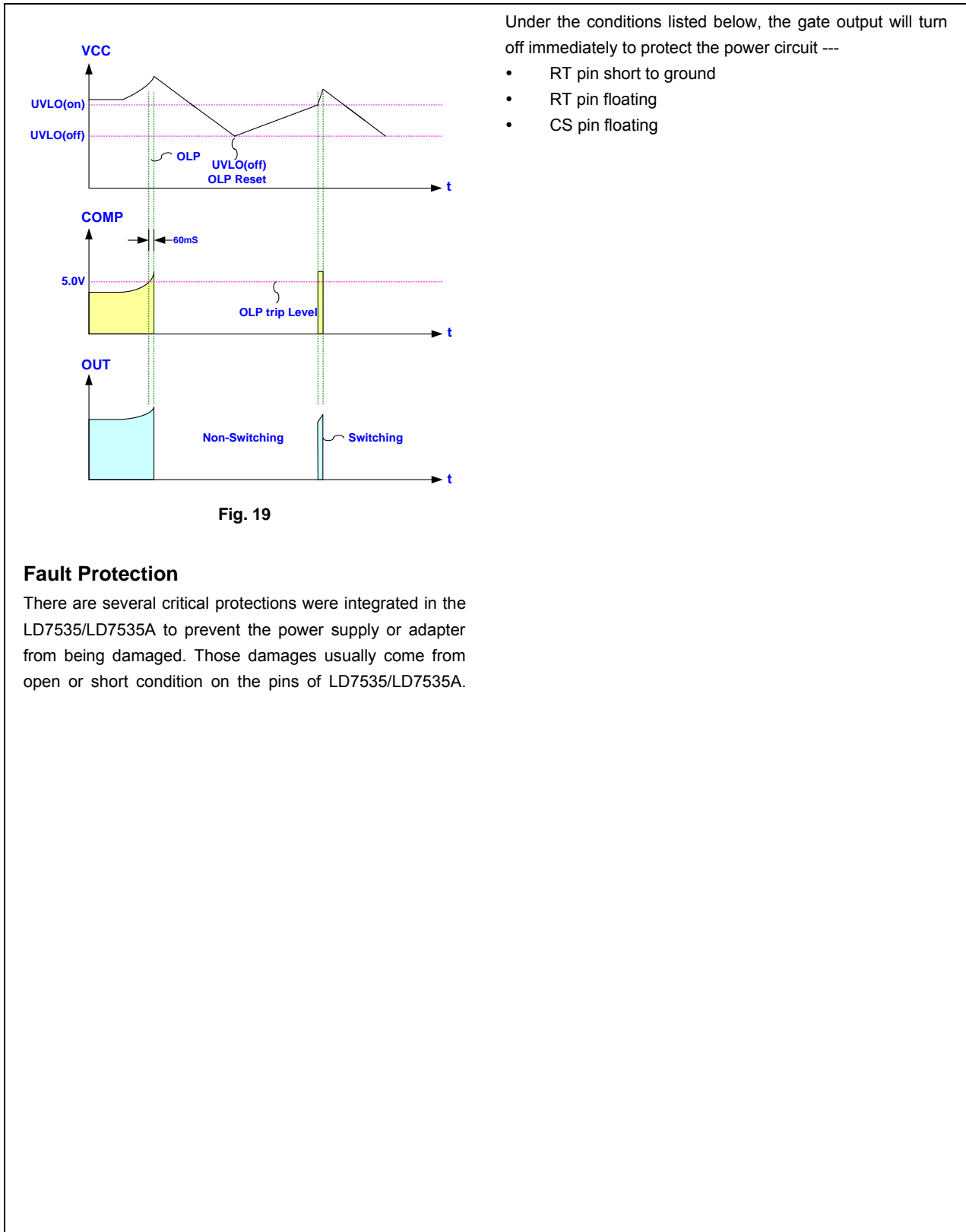

Fault Protection

There are several critical protections were integrated in the LD7535/LD7535A to prevent the power supply or adapter from being damaged. Those damages usually come from open or short condition on the pins of LD7535/LD7535A.

Reference Application Circuit --- 10W (5V/2A) Adapter

Schematic

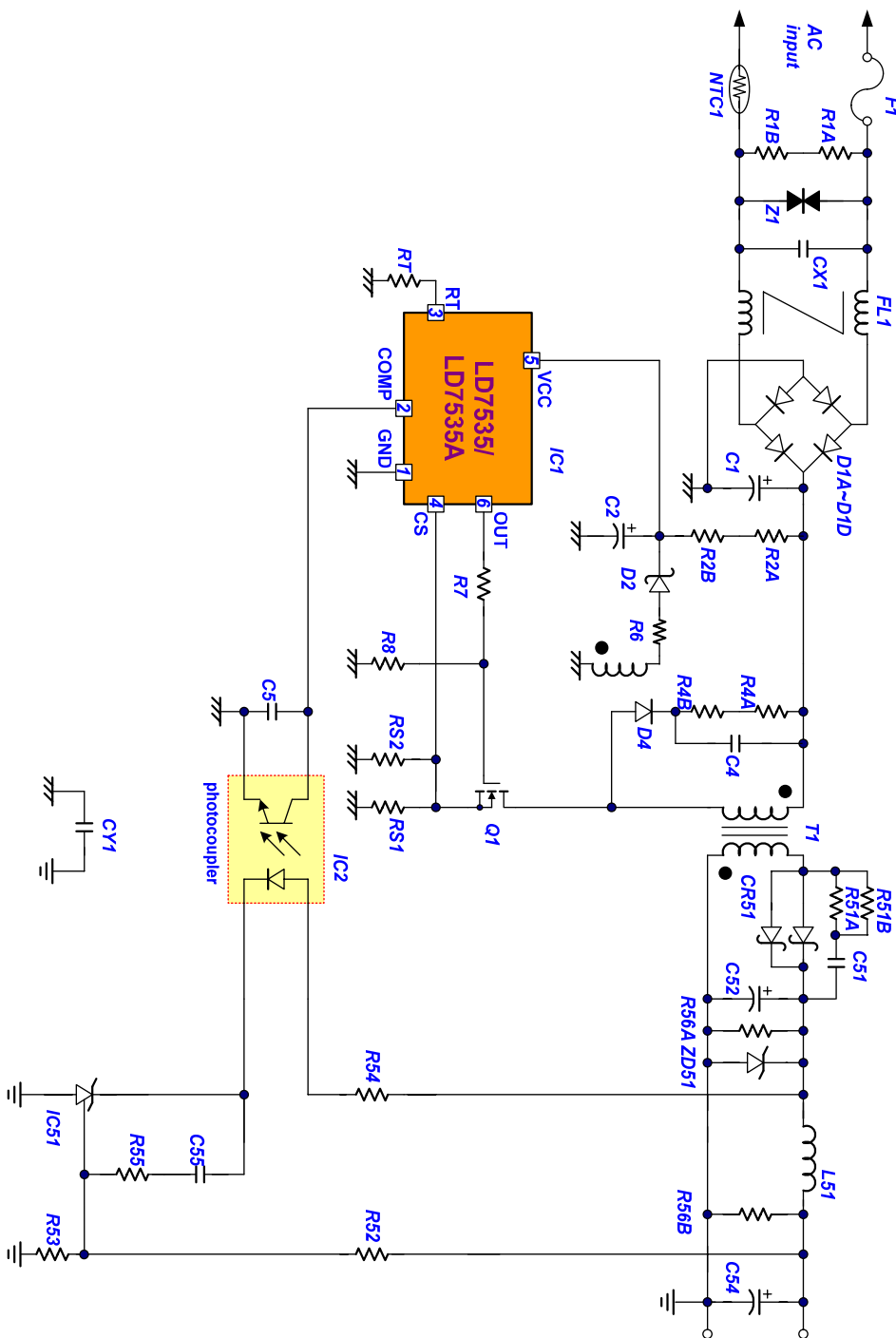

Reference Application Circuit --- 10W (5V/2A) Adapter

BOM

P/N	Component Value	Original
R1A	N/A	
R1B	N/A	
R2A	750K Ω , 1206	
R2B	750K Ω , 1206	
R4A	39K Ω , 1206	
R4B	39K Ω , 1206	
R6	10 Ω , 1206	
R7	10 Ω , 1206	
R8	10K Ω , 1206	
RS1	2.70 Ω , 1206, 1%	
RS2	2.70 Ω , 1206, 1%	
RT	100K Ω , 0805, 1%	
R51A	100 Ω , 1206	
R51B	100 Ω , 1206	
R52	2.49K Ω , 0805, 1%	
R53	2.49K Ω , 0805, 1%	
R54	220 Ω , 0805	
R55	10K Ω , 0805	
R56A	510 Ω , 1206	
R56B	N/A	
NTC1	08SP005	
FL1	20mH	UU9.8
T1	EI-22	
L51	2.7 μ H	

P/N	Component Value	Note
C1	22 μ F, 400V	L-tec
C2	10 μ F, 50V	
C4	1000pF, 1000V, 1206	Holystone
C5	0.01 μ F, 16V, 0805	
C51	1000pF, 50V, 0805	
C52	1000 μ F, 10V	L-tec
C54	470 μ F, 10V	L-tec
C55	0.01 μ F, 16V, 0805	
CX1	0.1 μ F	X-cap
CY1	2200pF	Y-cap
D1A	1N4007	
D1B	1N4007	
D1C	1N4007	
D1D	1N4007	
D2	PS102R	
D4	1N4007	
Q1	2N60B	600V/2A
CR51	SB540	
ZD51	6V2C	
IC1	LD7535/LD7535A BL	SOT-26
IC2	EL817B	
IC51	TL431	1%
F1	250V, 1A	
Z1	N/A	

LD7535/LD7535A

Reference Application Circuit #2 --- 10W Adapter with 2-Stage Startup Circuit

$P_{in} < 0.25W$ when $P_{out} = 0W$

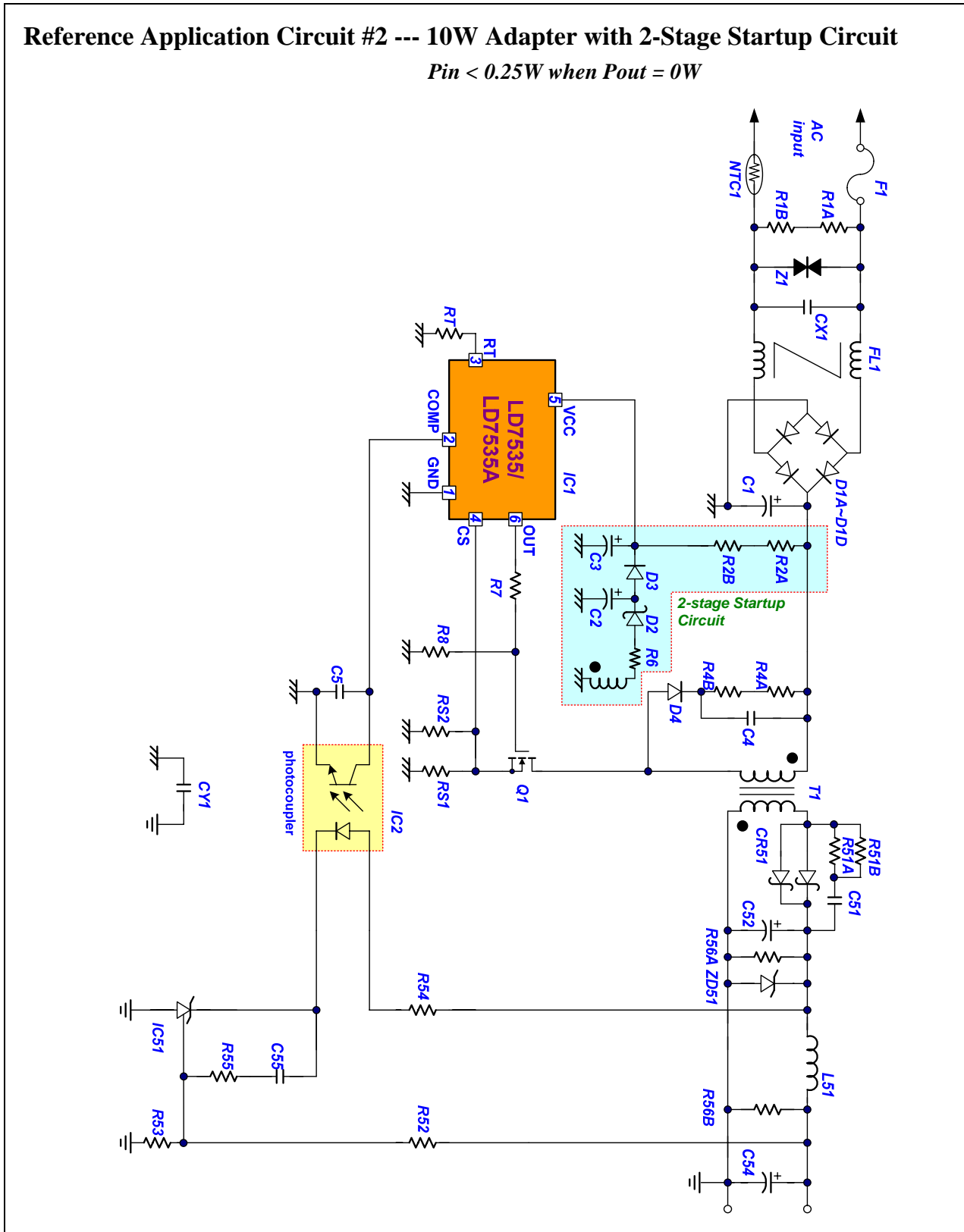

Reference Application Circuit #2 --- 10W Adapter with 2-Stage Startup Circuit

BOM

P/N	Component Value	Original
R1A	N/A	
R1B	N/A	
R2A	2.2MΩ, 1206	
R2B	2.2MΩ, 1206	
R4A	39KΩ, 1206	
R4B	39KΩ, 1206	
R6	2.2Ω, 1206	
R7	10Ω, 1206	
R8	10KΩ, 1206	
RS1	2.70Ω, 1206, 1%	
RS2	2.70Ω, 1206, 1%	
RT	100KΩ, 0805, 1%	
R51A	100Ω, 1206	
R51B	100Ω, 1206	
R52	2.49KΩ, 0805, 1%	
R53	2.49KΩ, 0805, 1%	
R54	220Ω, 0805	
R55	10KΩ, 0805	
R56A	1KΩ, 1206	
R56B	N/A	
NTC1	5Ω, 3A	08SP005
FL1	20mH	UU9.8
T1	EI-22	
L51	2.7μH	

P/N	Component Value	Note
C1	22μF, 400V	L-tec
C2	10μF, 50V	L-tec
C3	2.2μF, 50V	
C4	1000pF, 1000V, 1206	Holystone
C5	0.01μF, 16V, 0805	
C51	1000pF, 50V, 0805	
C52	1000μF, 10V	L-tec
C54	470μF, 10V	L-tec
C55	0.01μF, 16V, 0805	
CX1	0.1μF	X-cap
CY1	2200pF	Y-cap
D1A	1N4007	
D1B	1N4007	
D1C	1N4007	
D1D	1N4007	
D2	PS102R	
D3	1N4148	
D4	1N4007	
Q1	2N60B	600V/2A
CR51	SB540	
ZD51	6V2C	
IC1	LD7535/LD7535A IL	SOT-26
IC2	EL817B	
IC51	TL431	1%
F1	250V, 1A	
Z1	N/A	

Package Information

SOT-26

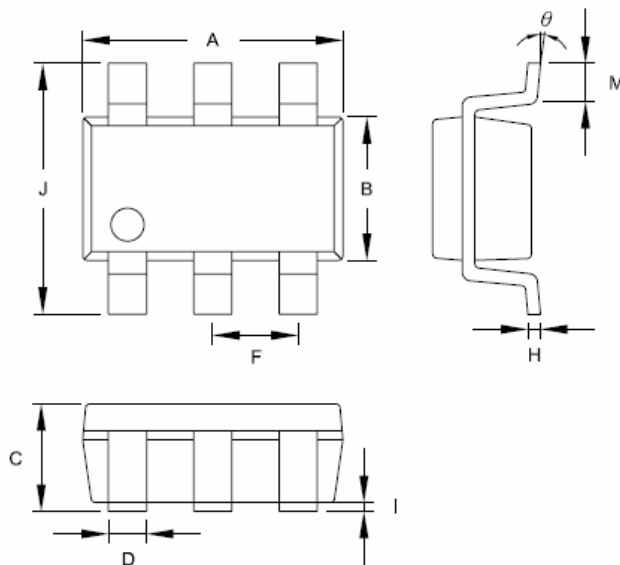

Symbol	Dimension in Millimeters		Dimensions in Inches	
	Min	Max	Min	Max
A	2.692	3.099	0.106	0.122
B	1.397	1.803	0.055	0.071
C	-----	1.450	-----	0.058
D	0.300	0.550	0.012	0.022
F	0.838	1.041	0.033	0.041
H	0.080	0.254	0.003	0.010
I	0.050	0.150	0.002	0.006
J	2.600	3.000	0.102	0.118
M	0.300	0.600	0.012	0.024
θ	0°	10°	0°	10°

Package Information

DIP-8

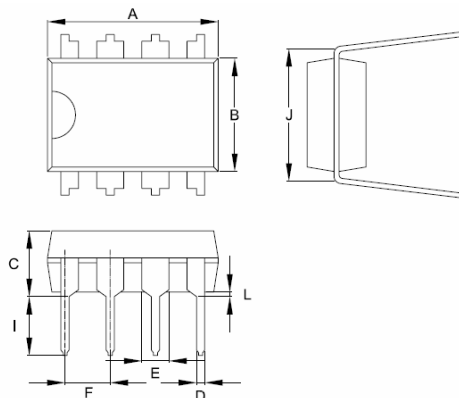

Symbol	Dimension in Millimeters		Dimensions in Inches	
	Min	Max	Min	Max
A	9.017	10.160	0.355	0.400
B	6.096	7.112	0.240	0.280
C	-----	5.334	-----	0.210
D	0.356	0.584	0.014	0.023
E	1.143	1.778	0.045	0.070
F	2.337	2.743	0.092	0.108
I	2.921	3.556	0.115	0.140
J	7.366	8.255	0.290	0.325
L	0.381	-----	0.015	-----

Important Notice

Leadtrend Technology Corp. reserves the right to make changes or corrections to its products at any time without notice. Customers should verify the datasheets are current and complete before placing order.

Revision History

Rev.	Date	Change Notice
00	03/01/'06	Renew from the LD7535 spec. (Rev=0) by adding the LD7535A related descriptions and data. The revision number is reset from 0.
01	01/11/07	Revision: Block Diagram and Characteristic
01a	5/17/07	Revision: Marking description
01b	11/29/07	Revision: green package option
01c	12/11/07	Revision: Block Diagram/ LD7535A OVP