

### Description

The 2301 is the new generation trench P-channel MOSFET has been designed to minimize the on-state resistance ( $R_{DS(ON)}$ ) yet maintain superior switching performance, making it ideal for high efficiency power management applications

### Features

- -20V, -4.5A,  $R_{DS(ON)} = 30m\Omega @ V_{GS} = -4.5V$
- Improved dv/dt capability
- G-S ESD Diode Embedded
- Fast switching
- Green Device Available

### Applications

- Notebook
- Load Switch
- Power Management

$V_{DSS}$	-20V
$I_D$	-4.5A
$R_{DS(ON)}$	$30m\Omega @ V_{GS} = -4.5V$
$R_{DS(ON)}$	$38m\Omega @ V_{GS} = -2.5V$

### Outline

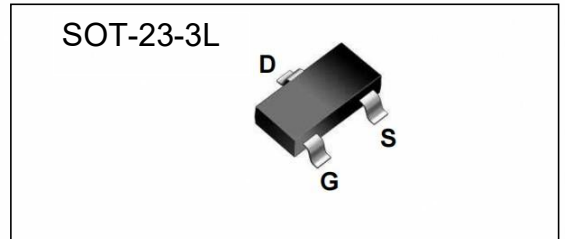

### Equivalent

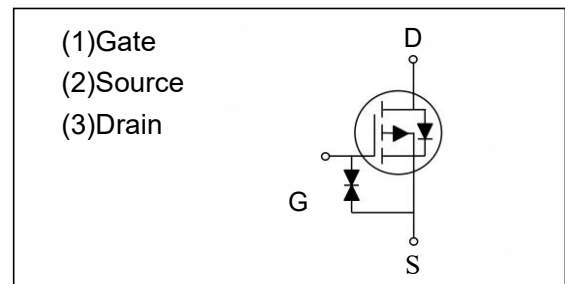

### Packaging specifications

Part No.	Package	Marking	Basic ordering unit.(pcs)
2301	SOT-23-3L		3000

### Absolute Maximum Ratings

Parameter	Symbol	Limit	Units	
Drain-Source Voltage	$V_{DS}$	-20	V	
Gate-Source Voltage	$V_{GS}$	$\pm 12$	V	
Drain Current-Continuous <sup>(Note2)</sup>	$I_D$	$T_A = 25^\circ C$	-4.5	A
		$T_A = 70^\circ C$	-3.6	A
-Pulsed <sup>(Note 1· Note 2)</sup>	$I_{DM}$	-18	A	
Maximum Power Dissipation	$P_D$	$T_A = 25^\circ C$	1.56	W
		$T_A = 70^\circ C$	0.98	W
Operating Junction and Storage Temperature Range	$T_J, T_{STG}$	-55 to 150	$^\circ C$	
Thermal Resistance Junction-Ambient	$R_{\theta JA}$	80	$^\circ C / W$	

## Electrical Characteristics (T<sub>c</sub>=25 °C, unless otherwise noted)

Parameter	Symbol	Test Conditions	Min	Typ	Max	Units
<b>OFF CHARACTERISTICS</b>						
Drain-Source Breakdown Voltage	BV <sub>DSS</sub>	V <sub>GS</sub> =0V , I <sub>D</sub> =-250uA	-20			V
Zero Gate Voltage Drain Current	I <sub>DSS</sub>	V <sub>DS</sub> =-20V , V <sub>GS</sub> =0V			-1	uA
Gate-Body Leakage Current	I <sub>GSS</sub>	V <sub>GS</sub> = ±12V , V <sub>DS</sub> =0V			±100	nA
<b>ON CHARACTERISTICS</b>						
Gate Threshold Voltage	V <sub>GS(th)</sub>	V <sub>DS</sub> = V <sub>GS</sub> , I <sub>D</sub> =250uA	-0.5	-0.6	-1.2	V
Drain-Source On-State Resistance	R <sub>DS(ON)</sub>	V <sub>GS</sub> =-4.5V , I <sub>D</sub> =-4.5A		30	38	mΩ
		V <sub>GS</sub> =-2.5V , I <sub>D</sub> =-3A		38	48	mΩ
<b>DYNAMIC CHARACTERISTICS</b> <small>Note4</small>						
Input Capacitance	C <sub>ISS</sub>	V <sub>DS</sub> =-10V , V <sub>GS</sub> =0 V , f =1.0MHz		1000		pF
Output Capacitance	C <sub>OSS</sub>			115		pF
Reverse Transfer Capacitance	C <sub>RSS</sub>			100		pF
Total Gate Charge	Q <sub>g</sub>	V <sub>DS</sub> =-10V , I <sub>D</sub> =-3A , V <sub>GS</sub> =-4.5V		8.3		nC
Gate-Source Charge	Q <sub>gs</sub>	V <sub>DS</sub> =-10V , I <sub>D</sub> =-3A , V <sub>GS</sub> =-4.5V		2.2		nC
Gate-Drain Charge	Q <sub>gd</sub>			2.8		nC
<b>SWITCHING CHARACTERISTICS</b> <small>Note4</small>						
Turn-On Delay Time	t <sub>D(ON)</sub>	V <sub>DD</sub> =-10V , I <sub>D</sub> =-1A , V <sub>GS</sub> =-4.5V , R <sub>G</sub> =25Ω		8.3		ns
Rise Time	t <sub>r</sub>			27		ns
Turn-Off Delay Time	t <sub>D(OFF)</sub>			45		ns
Fall Time	t <sub>f</sub>			14.6		ns
<b>DRAIN-SOURCE DIODE CHARACTERISTICS AND MAXIMUM RATINGS</b>						
Diode Forward Voltage	V <sub>SD</sub>	V <sub>GS</sub> =0V , I <sub>S</sub> =-4.5A			-1.0	V

### Notes:

- 1、 Pulse Test Width < 300us,Duty Cycle< 2%
- 2、 Drain current limited by maximum junction temperature.
- 3、 Guaranteed by design,not subject to production testing.

## Typical Performance Characteristics

**Fig.1 Continuous Drain Current vs. TC**

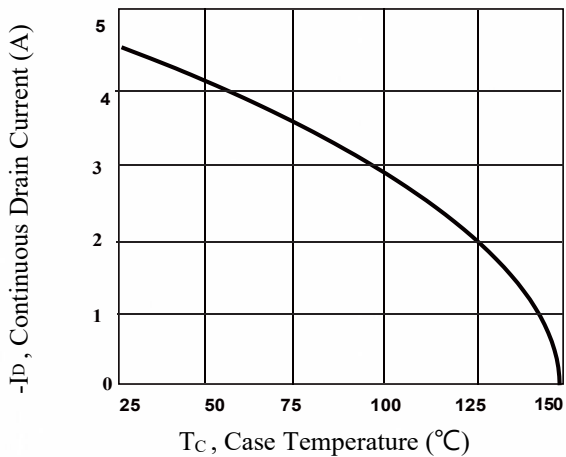

**Fig.2 Normalized RDSON vs. TJ**

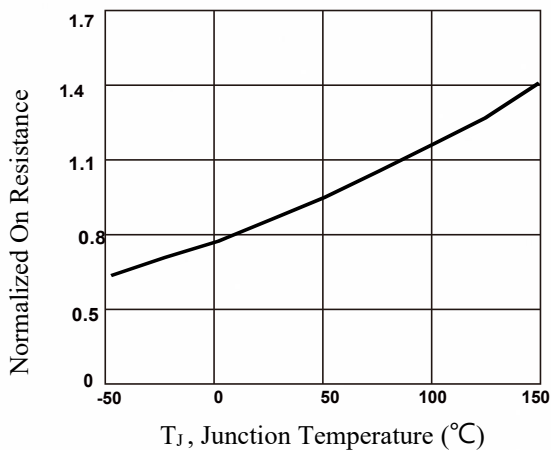

**Fig.3 Normalized Vth vs. TJ**

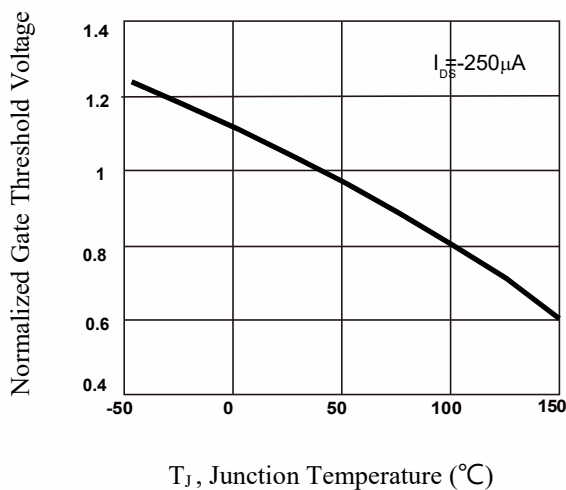

**Fig.4 Gate Charge Waveform**

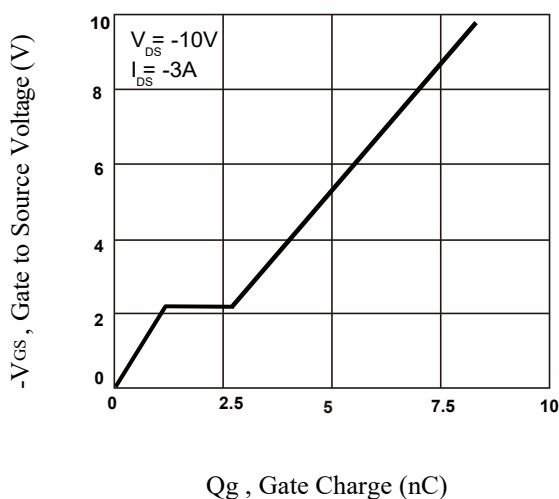

**Fig.5 Typical Output Characteristics**

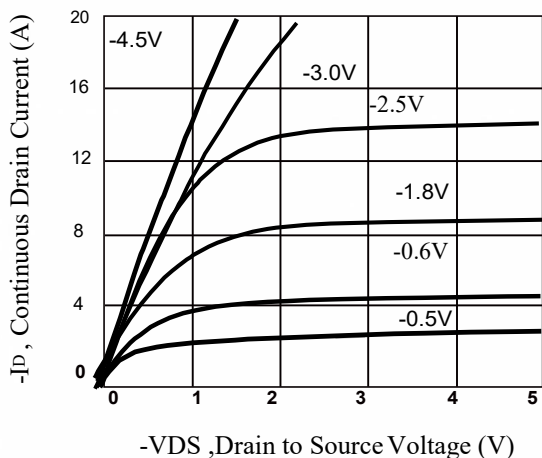

**Fig.6 Capacitance**

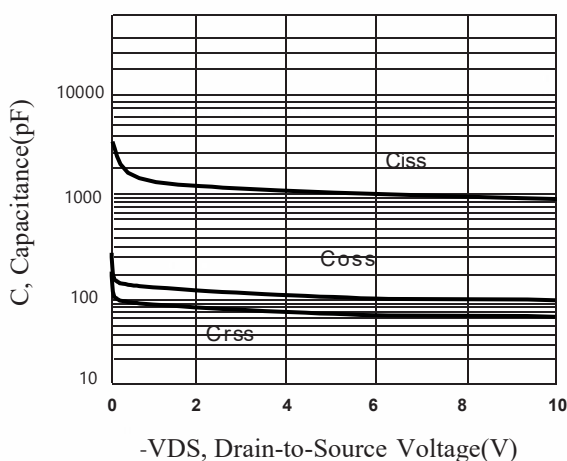

**Fig.7 Turn-On Resistance vs. ID**

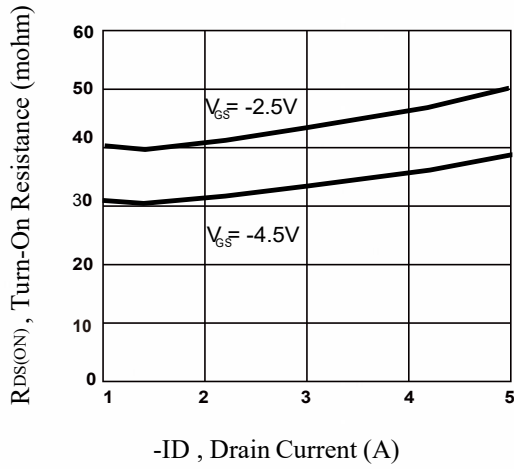

**Fig.8 Typical Source-Drain Diode Forward Voltage**

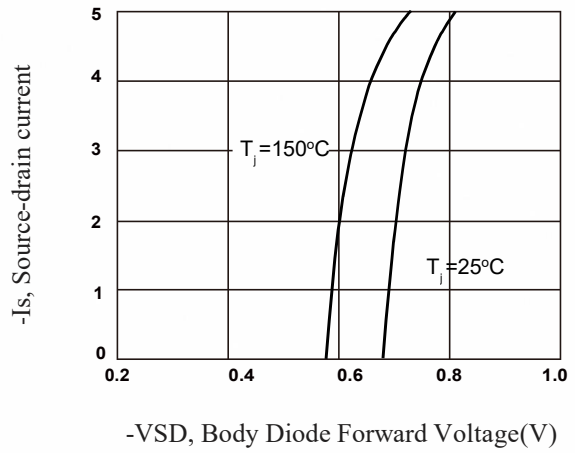

**Fig.9 Normalized Transient Impedance**

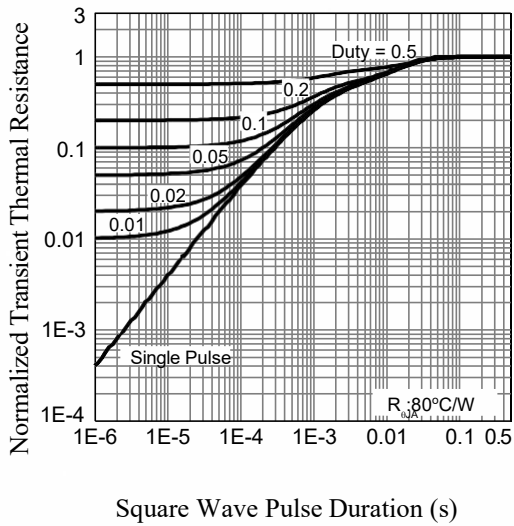

**Fig.10 Maximum Safe Operation Area**

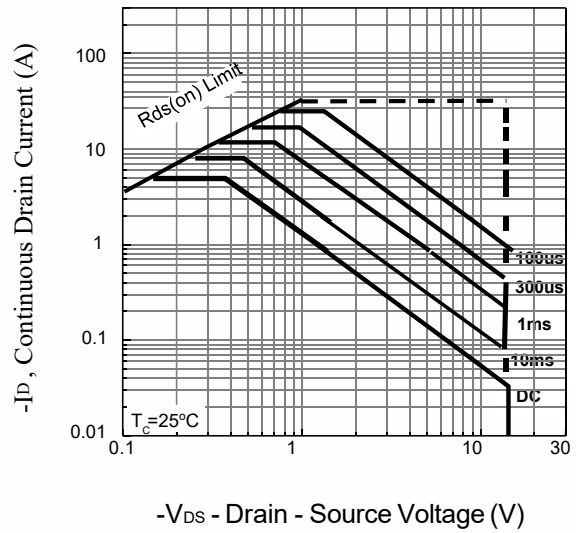

**Figure11a. Switching Test Circuit**

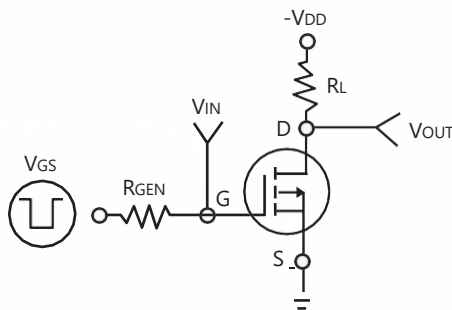

**Figure11b. Switching Waveforms**

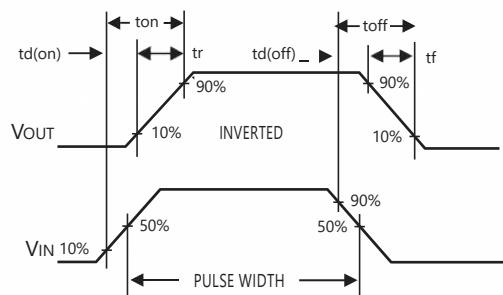

## SOT-23-3L Package Information

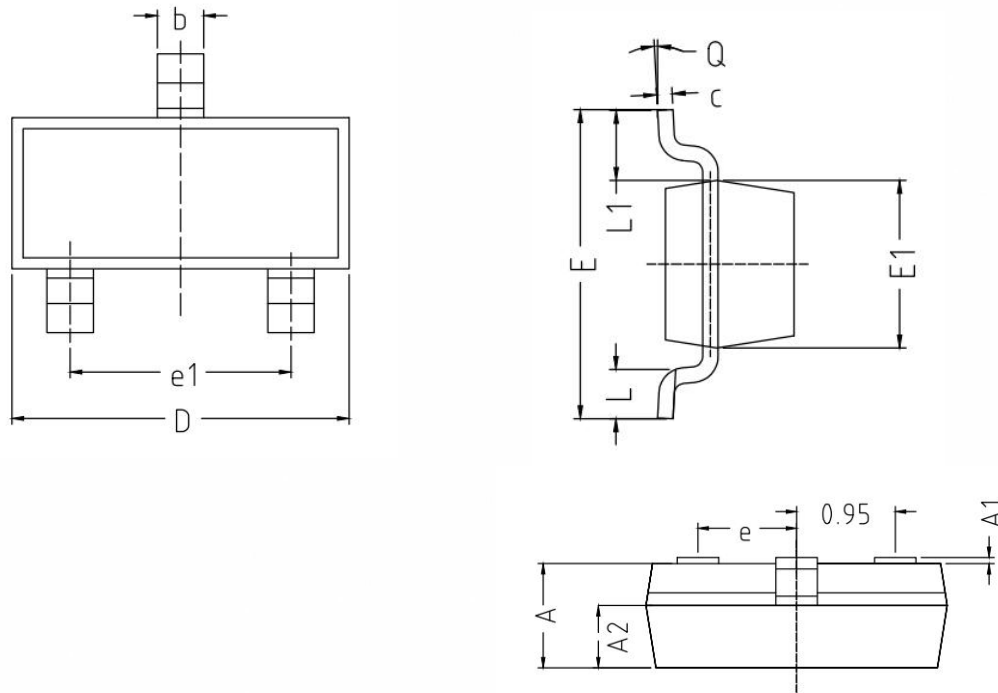

SOT-23-3L PKG

SYMBOL	MIN	MAX
A	1.050	1.100
A1	0.000	0.100
A2	1.000	1.050
b	0.300	0.450
c	0.100	0.200
D	2.800	3.000
E	2.650	2.750
E1	1.500	1.600
e	0.90	0.95
e1	1.800	2.00
L	0.35	0.450
L1	0.40	0.45
Q	8°	9°

### NOTICE

NKGL reserves the to make modifications,enhancements,improvements,corrections or other changes without further notice to any product herein.NKGL does not assume any liability arising out of the application or use of any product described herein.