

## GENERAL DESCRIPTION

OB3635A is an offline LED lighting controller with high power factor, low THD and high constant current (CC) precision. It can achieve low system cost for an isolated lighting application by primary side control in a single stage converter. It significantly simplifies the LED lighting system design by eliminating the secondary side feedback components and the opto-coupler.

The proprietary CC control scheme is used and the system can achieve high power factor with constant on-time control scheme. Quasi-resonant (QR) operation and clamping frequency greatly improves the system efficiency. The advanced start-up technology is used to meet the start-up time requirement (<0.5s). The constant output current is compensated for tolerance of transformer inductance variation. And the line compensation and load compensation are built in OB3635A for high precisely constant output current control.

OB3635A offers comprehensive protection coverage with auto-recovery features including LED open loop protection, LED short circuit protection, cycle-by-cycle current limiting, built-in leading edge blanking, VDD under voltage lockout (UVLO), etc.

OB3635A is offered in SOT23-6 package.

## FEATURES

- High PF (>0.9)
- Low THD (<10%)
- High precision constant current regulation at universal AC input
- Fast start-up (<0.5s)
- Primary-side sensing and regulation without TL431 and opto-coupler
- Low system cost and high efficiency
- Quasi-resonant operation
- Programmable CC regulation
- Built-in primary winding inductance compensation
- Built-in line compensation
- Built-in load compensation
- LED short circuit protection
- LED open loop protection
- Cycle-by-cycle current limiting
- Built-in leading edge blanking (LEB)
- VDD under voltage lockout with hysteresis
- VDD over voltage protection
- Over temperature protection (OTP)
- Thermal fold-back control

## APPLICATIONS

- LED lighting

## TYPICAL APPLICATION

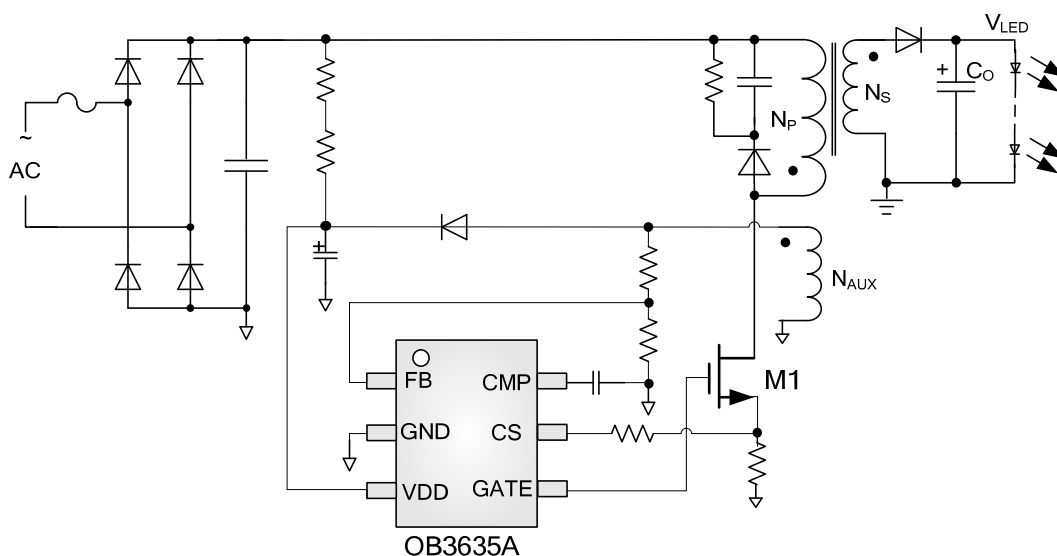

### GENERAL INFORMATION

#### Pin Configuration

The pin map is shown as below for SOT23-6.

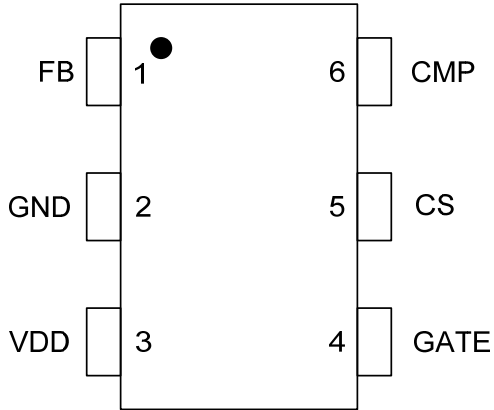

#### Ordering Information

Part Number	Description
OB3635AMP	SOT23-6, Pb-free, T&R

**Note:** All Devices are offered in Pb-free Package if not otherwise noted.

#### Package Dissipation Rating

Package	R $\theta$ JA (°C/W)
SOT23-6	200

#### Absolute Maximum Ratings

Parameter	Value
VDD Voltage	-0.3 to 40V
Gate Voltage	-0.3 to 40V
CS Input Voltage	-0.3 to 7V
FB Input Voltage	-0.3 to 7V
COMP Voltage	-0.3 to 7V
Min/Max Operating Junction Temperature T <sub>J</sub>	-40 to 150 °C
Min/Max Storage Temperature T <sub>stg</sub>	-55 to 150 °C
Lead Temperature (Soldering, 10secs)	260 °C

**Note:** Stresses beyond those listed under “absolute maximum ratings” may cause permanent damage to the device. These are stress ratings only, functional operation of the device at these or any other conditions beyond those indicated under “recommended operating conditions” is not implied. Exposure to absolute maximum-rated conditions for extended periods may affect device reliability.

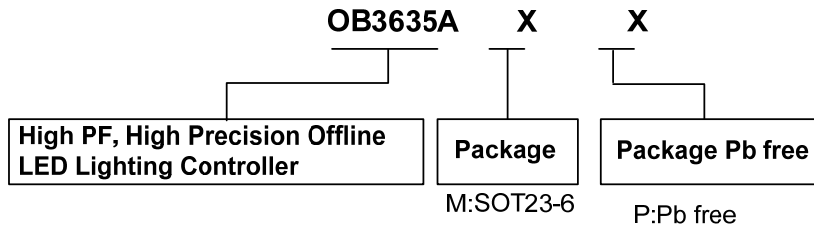

### Marking Information

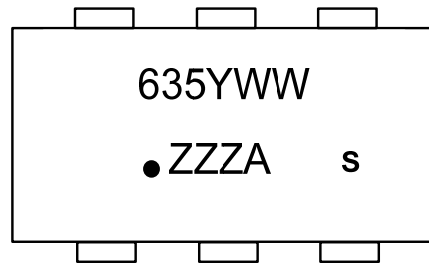

Y: Year Code  
 WW: Week Code(01-52)  
 ZZZ: Lot Code  
 A: Character Code  
 s: Internal Code(Optional)

### TERMINAL ASSIGNMENTS

Pin Num	Pin Name	I/O	Description
1	FB	I	Voltage feedback from auxiliary winding. Connected to resistor divider from auxiliary winding reflecting output voltage.
2	GND	P	Power Ground.
3	VDD	P	Power supply Input.
4	GATE	O	Gate driver output for power MOSFET.
5	CS	I	Current sensing terminal.
6	CMP	O	Loop compensation pin. A capacitor is connected between CMP and GND.

**BLOCK DIAGRAM**

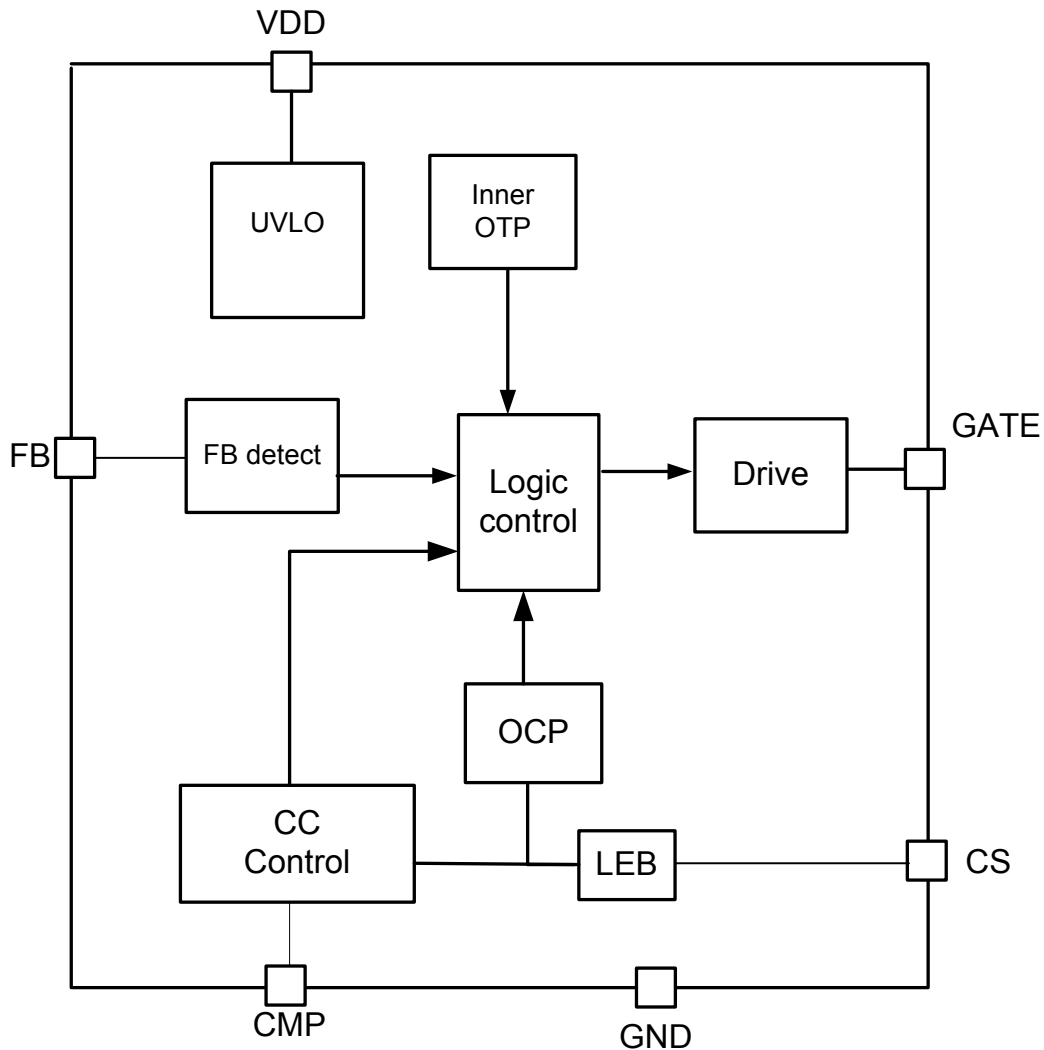

## ELECTRICAL CHARACTERISTICS

(TA = 25°C, VDD=20V, if not otherwise noted)

Symbol	Parameter	Test Conditions	Min	Typ.	Max	Unit
<b>Supply Voltage (VDD) Section</b>						
I <sub>start-up</sub>	Start up current	VDD=UVLO(OFF)-1V		3	7	uA
I <sub>op</sub>	Operation current	VDD=20V, no loading		0.4	0.6	mA
UVLO(OFF)	VDD under voltage lockout exit		16	18	20	V
UVLO(ON)	VDD under voltage lockout enter		7	8	9	V
VDD_OVP	VDD Over Voltage Protection		30	32	34	V
<b>Current Sense Input Section</b>						
TLEB	LEB time			0.4		us
V <sub>th_ocp</sub>	Over Current Threshold	FB>0.25V	1.05	1.1	1.15	V
		FB<=0.25V		0.5		V
<b>FB Input Section</b>						
V <sub>out_ovp</sub>	Output Over Voltage Protection		1.42	1.5	1.58	V
V <sub>out_scp</sub>	Output Short Circuit Protection			0.25		V
<b>QR Section</b>						
F <sub>max</sub>	Maximum Clamping Frequency			100		KHz
T <sub>off_max</sub>	Maximum Off Time			100		us
T <sub>off_min</sub>	Minimum Off Time	CS>0.15V		2		us
		CS<=0.15V		0.5		us
T <sub>on_max</sub>	Maximum On Time			25		us
<b>Error Amplifier Section</b>						
V <sub>ref</sub>	Error Amplifier Reference Voltage		0.196	0.200	0.204	V
G <sub>m</sub>	Error Amplifier Transconductance			40		uS
V <sub>clamp_cmp</sub>	CMP Pin Down_clamp Voltage			1.0		V
<b>Gate Driver Section</b>						
V <sub>ol</sub>	Output Low Level	I <sub>out</sub> =10mA			1	V
V <sub>oh</sub>	Output High Level	I <sub>out</sub> =10mA	6			V
V <sub>clamp</sub>	Output Up-Clamping Voltage		10	12	14	V
T <sub>r</sub>	Rising Edge Time	C <sub>l</sub> =1nF		90		ns
T <sub>f</sub>	Falling Edge Time	C <sub>l</sub> =1nF		30		ns
<b>OTP Section</b>						
T <sub>TF</sub>	Thermal regulation threshold			145		°C
OTP	Over Temperature Protection			170		°C

**CHARACTERIZATION PLOTS**

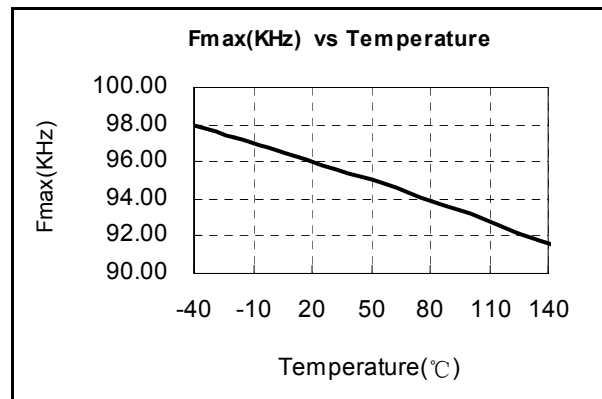
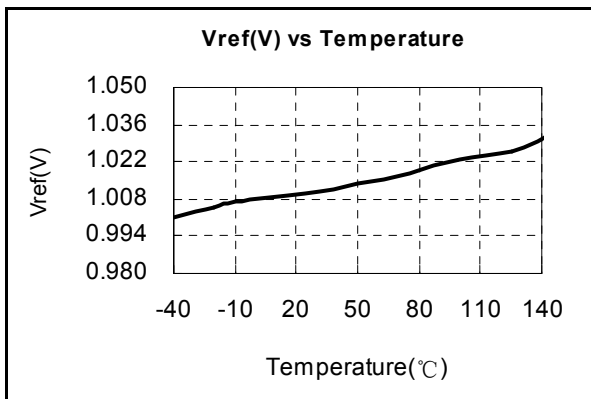
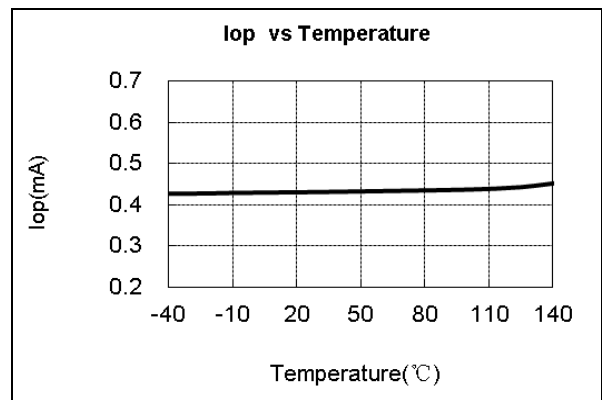
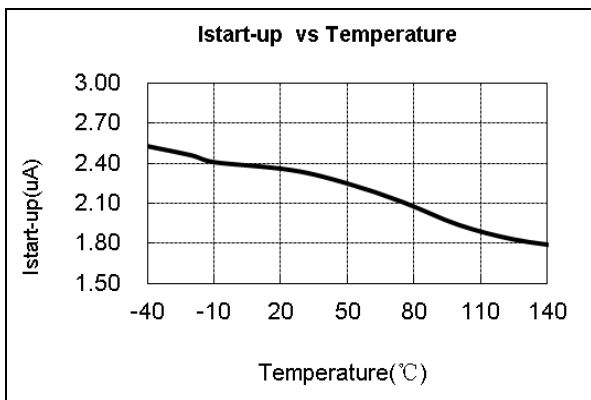
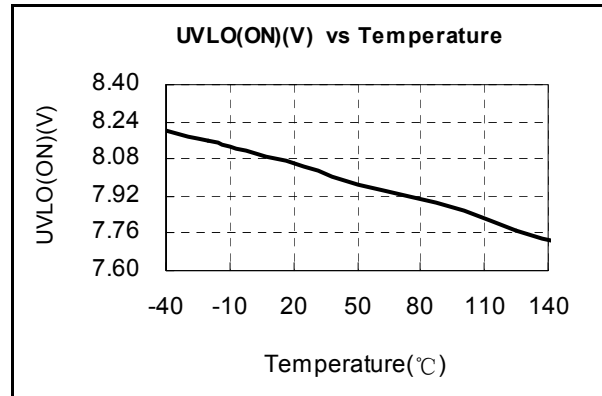
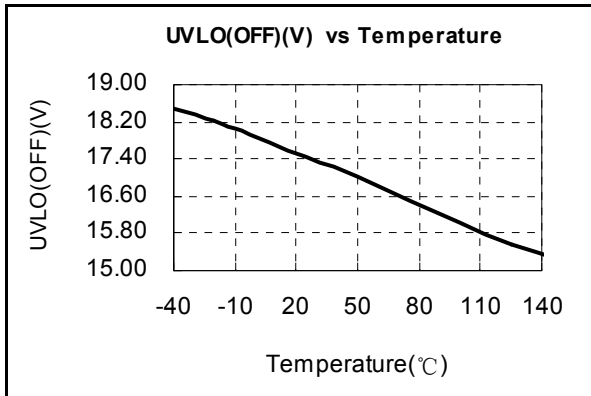

### OPERATION DESCRIPTION

OB3635A is a primary-side-control and high power factor, low THD fly-back PWM controller specialized for LED lighting application. It operates in primary side sensing and regulation, thus opto-coupler and TL431 are not required. OB3635A works at Quasi-Resonant operation with maximum working frequency clamping, which can improve the efficiency of LED lighting system design.

- **Start up Control**

The advanced start-up technology is used in OB3635A to meet the start-up time requirement (<0.5s). Low start-up current is designed in OB3635A so that VDD could be charged up above UVLO threshold with small charging current.

At the startup, the capacitor at CMP pin is pulled up quickly. OB3635A operates at open loop and over-current protection is set cycle-by-cycle until it senses the output voltage by FB pin up to about 0.6V. After that OB3635A operates in close loop and the transconductance of error amplifier is set to 40uS (typical).

- **LED Constant Current Regulation**

The LED output current equals to the average of the output rectifier diode current. So the LED output current is related with the transformer peak current value and the transformer current discharge time. The transformer current discharge time is sensed through FB pin and the transformer peak current value is determined by internal reference voltage. A proprietary CC control block calculates LED output current through the CS pin peak current value and the transformer current discharge time. The output of the calculation is compared with an internal precise reference to generate an error voltage (Vcmp), which determines the turn-on time in voltage mode control. The LED output current can be approximated as:

$$I_{LED} = \eta \cdot \frac{N}{2} \cdot \frac{V_{ref}}{R_{CS}}$$

$\eta$  — The transformer coupling coefficient.

$N$  — Turn ratio of primary side winding to secondary side winding.

$R_{CS}$  — The sensing resistor connected between the MOSFET source and GND.

$V_{ref}$  — Internal reference voltage.

- **PFC and THD**

The duration of the turn on period  $t_{on}$  is generated by comparing an internal fixed saw-tooth wave with the voltage on the CMP pin. During steady state operation, the voltage on the CMP pin  $V_{cmp}$  is slowly varying due to a large external capacitor

connected at the CMP pin, therefore the turn on time  $t_{on}$  is constant. In a fly-back topology, constant turn on time and quasi-resonant operation provide high power factor (PF) and low total harmonic distortion (THD).

- **Current Sensing and Leading Edge Blanking**

Cycle-by-Cycle current limiting (OCP) is offered in OB3635A. The switching current is detected by a sense resistor connected between the CS pin and GND. An internal leading edge blanking circuit chops off the sense voltage spike at initial MOSFET on state due to snubber diode reverse recovery so that the external RC filter is no longer required. The current limit comparator is disabled at this blanking time and thus the external MOSFET cannot be turned off during this blanking time.

- **Quasi-Resonant Operation**

OB3635A performs quasi-resonant detection through FB pin by monitoring the voltage activity on the auxiliary windings in series with external resistors. When the stored energy of fly-back transformer is fully released to the output, the voltage at FB pin decreases. When FB pin voltage falls below 0.05V (typical), an internal FB comparator is triggered and a new PWM switching cycle is initiated following the FB triggering.

- **Line/Load Compensation**

OB3635A provides internal line compensation and load compensation to avoid using outside sensing devices. The compensated voltage is added to CS voltage cycle-by-cycle and LED output current is kept constant under different line voltage and output voltage.

- **VDD Over Voltage Protection**

VDD is supplied with transformer auxiliary winding output. When VDD is higher than 32V (typical), VDD OVP protection is triggered and GATE is shut down, and the device enters power on startup sequence thereafter.

- **Thermal Fold-back Protection**

OB3635A provides thermal foldback function to control LED output current. When temperature is up to 145°C (typical) and the output current of system will be adjusted according to the sensed temperature. The output current will be reduce to about half of the setting value at 165°C (typical). Over temperature protection is offered in OB3635A. When temperature rises above 170°C (typical), the device will stop working.

- **LED Short Circuit Protection**

When LED string is short, the positive plateau of auxiliary winding voltage is also near zero and the FB voltage is low. If the voltage at FB pin is lower than a threshold of approximately 0.25V (typical), the IC will work at minimum frequency and the threshold voltage of OCP is reduced to 0.5V (typical). The power dissipation is greatly reduced in this way.

- **LED Open Circuit Protection**

When the LED string open circuit happens, the positive plateau of auxiliary winding voltage increases and the FB pin voltage is high. If the

voltage at FB pin is higher than a threshold of approximately 1.5V (typical), the IC will shut down and enter power on startup sequence thereafter.

- **Gate Driver**

The GATE pin is connected to the gate of an external power switch. An internal 12V (typical) clamp is added for MOSFET gate protection at high VDD voltage. When VDD voltage drops below UVLO (ON), the GATE pin is internally pulled low to maintain the off state.

**PACKAGE MECHANICAL DATA**

**SOT-23-6L PACKAGE OUTLINE DIMENSIONS**

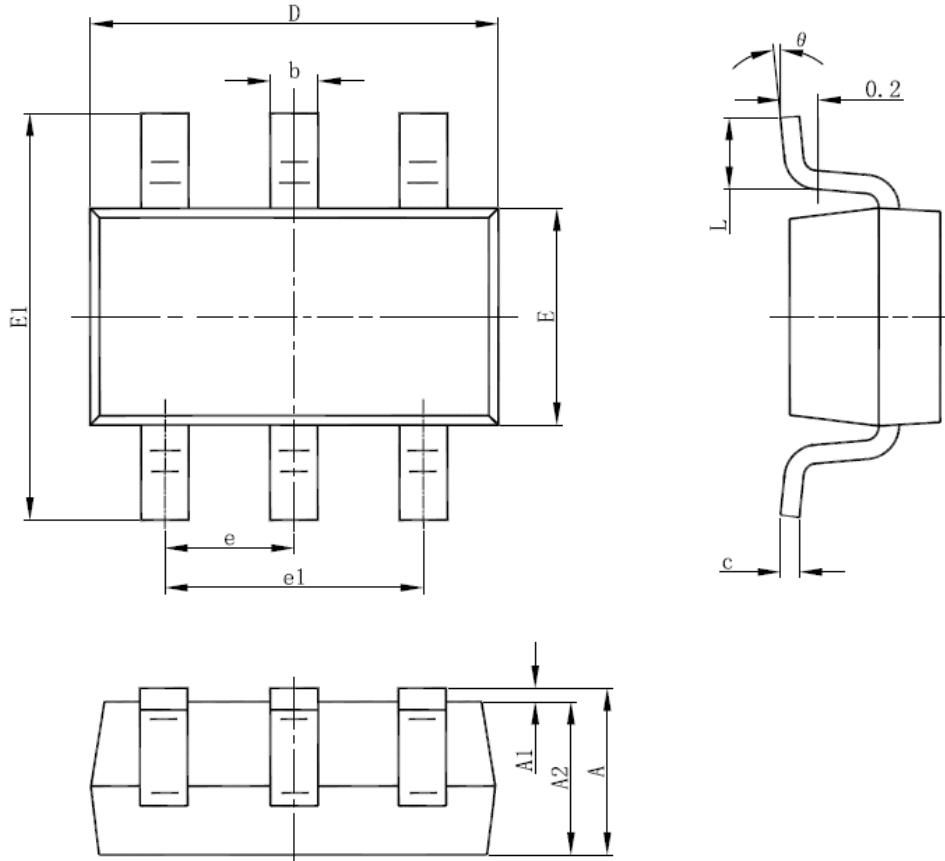

Symbol	Dimensions In Millimeters		Dimensions In Inches	
	Min	Max	Min	Max
A	1.000	1.450	0.039	0.057
A1	0.000	0.150	0.000	0.006
A2	0.900	1.300	0.035	0.051
b	0.300	0.500	0.012	0.020
c	0.080	0.220	0.003	0.009
D	2.800	3.020	0.110	0.119
E	1.500	1.726	0.059	0.068
E1	2.600	3.000	0.102	0.118
e	0.950 (BSC)		0.037 (BSC)	
e1	1.800	2.000	0.071	0.079
L	0.300	0.600	0.012	0.024
θ	0°	8°	0°	8°

## **IMPORTANT NOTICE**

### **RIGHT TO MAKE CHANGES**

On-Bright Electronics Corp. reserves the right to make corrections, modifications, enhancements, improvements and other changes to its products and services at any time and to discontinue any product or service without notice. Customers should obtain the latest relevant information before placing orders and should verify that such information is current and complete.

### **WARRANTY INFORMATION**

On-Bright Electronics Corp. warrants performance of its hardware products to the specifications applicable at the time of sale in accordance with its standard warranty. Testing and other quality control techniques are used to the extent it deems necessary to support this warranty. Except where mandated by government requirements, testing of all parameters of each product is not necessarily performed.

On-Bright Electronics Corp. assumes no liability for application assistance or customer product design. Customers are responsible for their products and applications using On-Bright's components, data sheet and application notes. To minimize the risks associated with customer products and applications, customers should provide adequate design and operating safeguards.

### **LIFE SUPPORT**

On-Bright Electronics Corp.'s products are not designed to be used as components in devices intended to support or sustain human life. On-bright Electronics Corp. will not be held liable for any damages or claims resulting from the use of its products in medical applications.

### **MILITARY**

On-Bright Electronics Corp.'s products are not designed for use in military applications. On-Bright Electronics Corp. will not be held liable for any damages or claims resulting from the use of its products in military applications.